



Operating and Service Manual

200T26z5G40A

Model

10027190

Part Number

Serial Number

EC Declaration of Conformity

We: Amplifier Research
160 School House Road
Souderton, PA. 18964

declare that our product(s);

the Model 200T26z5G40A series RF amplifiers

to which this declaration relates is in compliance with the following European directives:

Low Voltage Directive: 2014/35/EU

EMC Directive: 2014/30/EU

Supplementary Information:

Safety : EN 60215-1:1989

EN 61010-1:2010

EMC: EN 61000-6-2:2005, EN61000-6-4:2007

Year Mark Applied: 2016

I, the undersigned, hereby declare that the equipment specified above conforms to the above Directives and Standards.

Authorized officer of the company:



James M. Maginn
President

INSTRUCTIONS FOR SAFE OPERATION









Observe the following safety guidelines to help ensure your own personal safety and to help protect your equipment and working environment from potential damage.

INTENDED USE

This equipment is intended for general laboratory use in generating, controlling, and measuring levels of electromagnetic Radio Frequency (RF) energy. Ensure that the device is operated in a location which will control the radiated energy and will not cause injury or violate regulatory levels of electromagnetic interference.

SAFETY SYMBOLS

These symbols may appear in your user manual or on equipment.

	This symbol is marked on the equipment when it is necessary for the user to refer to the manual for important safety information. The caution symbol denotes a potential hazard. Attention must be given to the statement to prevent damage, destruction, or harm.
	Dangerous voltages are present. Use extreme care.
	Indicates a terminal intended for connection to an external conductor for protection against electrical shock in case of a fault, or the terminal of a protective earth (ground) electrode.
	Indicates invisible laser radiation—do not view directly with optical instruments.
	Indicates frame or chassis ground connection terminal.
	Indicates alternating current.
	Indicates this product must not be disposed of with your other household waste.
	Indicates that the marked surface and adjacent surfaces can attain temperatures that may be hot to the touch.

EQUIPMENT SETUP PRECAUTIONS

 Review the user manual and become familiar with all safety markings and instructions. Protection provided by the equipment may be impaired if used in a manner not specified by AR RF/Microwave Instrumentation (AR).

- Follow all lifting instructions specified in this document.
- Place the equipment on a hard, level surface.
- Do not use the equipment in a wet environment, for example, near a sink, or in a wet basement.

- Position your equipment so that the power switch is easily accessible.
- Leave 10.2 cm (4 in) minimum of clearance on all vented sides of the equipment to permit the airflow required for proper ventilation. Do not restrict airflow into the equipment by blocking any vents or air intakes. Restricting airflow can result in damage to the equipment, intermittent shut-downs or safety hazards.
- Keep equipment away from extremely hot or cold temperatures to ensure that it is used within the specified operating range.
- While installing accessories such as antennas, directional couplers and field probes, take care to avoid any exposure to hazardous RF levels.
- Ensure that nothing rests on your equipment's cables and that the cables are not located where they can be stepped on or tripped over.
- Move equipment with care; ensure that all casters and/or cables are firmly connected to the system. Avoid sudden stops and uneven surfaces.

BEFORE APPLYING POWER

Your AR equipment may have more than one power supply cable. Use only approved power cable(s). If you have not been provided with a power cable for the equipment or for any AC-powered option intended for the equipment, purchase a power cable that is approved for use in your country. The power cable must be rated for the equipment and for the voltage and current marked on the equipment's electrical ratings label.



Incorrectly installing or using an incompatible line voltage may increase the risk of fire or other hazards. To help prevent electric shock, plug the equipment and peripheral power cables into properly grounded electrical outlets. These cables are equipped with three-prong plugs to help ensure proper grounding. Do not use adapter plugs or remove the grounding prong from a cable.

Do not modify power cables or plugs. Consult a licensed electrician or AR trained service technician for equipment modifications. Always follow your local/national wiring rules.



Do not operate the equipment if there is physical damage, missing hardware, or missing panels.

SAFETY GROUND



This equipment is provided with a protective earth terminal. The mains power source to the equipment must supply an uninterrupted safety ground of sufficient size to attach wiring terminals, power cord, or supplied power cord set. ***DO NOT USE this equipment if this protection is impaired.***

INSTRUCTIONS FOR SAFE OPERATION

HAZARDOUS RF VOLTAGES



The RF voltages on the center pin of an RF output connector can be hazardous. The RF output connector should be connected to a load before AC power is applied to the equipment. Do not come into contact with the center pin of the RF output connector or accessories connected to it. Place the equipment in a non-operating condition before disconnecting or connecting the load to the RF output connector.

ACOUSTIC LIMITATIONS

If equipment noise exceeds 80dB, ear protection is required.

MAINTENANCE CAUTION

Adjustment, maintenance, or repair of the equipment must be performed only by qualified personnel. Hazardous energy may be present while protective covers are removed from the equipment even if disconnected from the power source. Contact may result in personal injury. Replacement fuses are required to be of specific type and current rating.

ENVIRONMENTAL CONDITIONS

Unless otherwise stated on the product specification sheet, this equipment is designed to be safe under the following environmental conditions:

- Indoor use
- Altitude up to 2000m
- Temperature of 5°C to 40°C
- Maximum relative humidity 80% for temperatures up to 31°C. Decreasing linearly to 50% at 40°C.
- Main supply voltage fluctuations not to exceed $\pm 10\%$ of the nominal voltage or minimum and maximum autoranging values.
- Pollution degree 2: Normally non-conductive with occasional condensation. While the equipment will not cause hazardous condition over this environmental range, its performance may vary.

EQUIPMENT CONTAINING LASERS



AR Field Probes (FL/PL Series) and Field Analyzers (FA Series) are Class 1 laser products containing embedded Class 4 lasers. Under normal use, the laser radiation is completely contained within the fiber optic cables and poses no threat of exposure. Safety interlocks ensure that the laser is not activated unless the cables are properly connected. Always exercise caution when using or maintaining laser products. Do not view directly with optical instruments.

RF ANTENNAS

- This equipment (antenna or antenna assembly) may be heavy, requiring two persons to lift. Use caution when installing or removing unit. Follow all equipment setup and lifting instructions specified in this document.
- Ensure connectors are appropriate for intended operation. Connectors are specified in the user manual and product specification sheet.
- Do not exceed the maximum RF input level stated in the specifications. Refer to the user manual and product specification sheet to determine the applicable RF levels.
- Excessive RF input could damage the equipment or connectors, causing safety hazards.
- When in operation, the RF voltages on the antenna elements can be hazardous. Do not come into contact with the antenna or elements when the RF input connector is connected to a live RF source.
- To avoid injury to personnel and accidental damage to power amplifier or antenna, disable the RF output of power amplifier before connecting or disconnecting the input connection to the antenna.
- Perform periodic inspections of antenna and field probe systems to verify calibration due date, proper operation, and overall condition of equipment.

RACK MOUNTED TWT MODELS

Some TWT models are supplied without the removable enclosure offered for benchtop use. These rack-mountable models may be supplied with either carry handles or slides and front handles installed. Follow all lifting instructions specified in this document and installation instructions supplied in the TWT user manual.

LIFTING INSTRUCTIONS FOR AR EQUIPMENT

Because most products must be handled during distribution, assembly and use, the risk of serious injury due to unsafe product handling should be a fundamental consideration of every user. An authoritative guideline for eliminating unwarranted risk of injury caused by lifting is provided by the NIOSH Work Practices (Publication #94-110) available at:



<https://www.cdc.gov/niosh/docs/94-110/pdfs/94-110.pdf>.

In general, observe the following guidelines for lifting a weight of 50 lb or more:

- Use lifting eye (for floor standing) or side handles (table top) to lift unit only.
- Use equipment of adequate capacity to lift and support unit.
- If using forklift to move unit, be sure forks are long enough to extend beyond the side of the unit.
- For additional information, follow the link specified above.

ADDITIONAL WARNINGS & NOTES



WARNING:

This equipment operates at potentially lethal voltages. Only trained, qualified personnel should operate, maintain, or service it.

Hazardous energy may be present while protective covers are removed from the equipment even if disconnected from the power source. Contact may result in personal injury.



CAUTION:

Adjustment, maintenance, or repair of the equipment must be performed only by qualified personnel.



CAUTION:

Replacement fuses are required to be of specific type and current rating.



CAUTION:

The information in this document was obtained from reliable sources and was believed to be accurate at the time of publication. Since subsequent modifications to the machine may have been made, use this information only as a guide. Carefully compare the unit's actual configuration and operation to the descriptions in this manual before you undertake to operate, service, or modify this machine. Any variance or modification should be noted, dated, and initialed in the discrepant part of all manuals on hand for future reference. If you have technical or editorial comments you wish to make to the manufacturer, please write them on photocopies of the relevant sheets.

NOTE: The contents of this document are the property of the manufacturer and this document is delivered on the express condition that it not be disclosed, reproduced in whole or in part, or used for manufacture for anyone other than the manufacturer without its written consent, and that no right is granted to disclose or so use any information in this document.

TABLE OF CONTENTS

TABLE OF CONTENTS.....	i
1. DESCRIPTION AND SPECIFICATIONS.....	1
1.1 TWTA Description.....	1
1.2 Suggested Applications.....	1
1.3 Specifications.....	1
1.4 Accessories.....	1
1.5 Test Data Sheet.....	2
2. THEORY OF OPERATION.....	5
2.1 Design of the amplifier.....	5
2.2 Description of the RF aSEMBLY.....	5
2.3 Description of the Power Supply.....	6
3. OPERATION.....	7
3.1 Warnings and Cautions.....	7
3.2 Installation.....	7
3.2.1 Unpacking.....	7
3.2.2 Mounting.....	8
3.2.3 Cooling Requirements.....	9
3.2.4 AC Line Power Connections.....	9
3.2.5 RF Output Connections.....	9
3.2.6 External Interlock Connector.....	10
3.2.7 External IEEE-488 Connector.....	10
3.3 Front Panel Features.....	11
3.4 Front Panel Display and Soft Keys.....	12
3.5 Rear Panel Features.....	16
3.6 Initial Turn On and Warm-up Procedure.....	17
3.7 Foldback Operation.....	18
3.8 Remote IEEE-488 Operation.....	18
3.9 TWTA General Considerations.....	23
4. MAINTENANCE.....	27
4.1 Safety Warning.....	27
4.2 Unauthorized Repairs.....	27
4.3 Preventive Maintenance.....	27
4.4 Troubleshooting.....	28
4.5 Non-Repairable Modules.....	29
5. TECHNICAL DOCUMENTATION.....	31
5.1 Top Level Build Tree.....	32
5.1.1 A33961-000, 200 Watt K Band HPA.....	32
5.1.2 A33962-000, 200 Watt KA Band HPA.....	33
5.2 Schematics.....	34
5.3 Parts Lists.....	35
5.3.1 Parts List, 200T 18G26z5A & 26z5G40A, HPA Logic and Control Module for 130K, 130KA, A16485-893.....	36

5.3.2	Parts List, 200T18G26z5A, HV Power Supply For L-3 TWT 8928H (Pulsed 2-Tube Unit), A22826-930	38
5.3.3	Parts List, 200T26z5G40A, HV Power Supply For L-3 TWT 8929H, A22826-931	38
5.3.3	Emergency Bypass Board, Low Level Foldback Trip (<1V); A24830-011	39
5.3.4	Parts List, HPA Interface Board (200UM Glass Fibers), A25444-001	40
5.3.5	Parts List, 200T18G26z5A, Microwave Power Assembly 200 Watt K-Band; A 28051-341	43
5.3.6	Parts List, 200T26z5G40A, Microwave Power Assembly 200KA, A28051-35144	43
5.3.7	Parts List, Wiring Kit, 200W KA Band (Glass Fibers); A28052-002	45
5.3.8	Parts List, VSWR/Foldback Board Assembly, A32363-000	47
5.3.9	Parts List, HPA 200 Watt K-Band W/ 2 L3 Tubes (AR), A33961-000.....	49
5.3.10	Parts List, HPA 200 Watt KA-Band W/ 2 L3 Tubes (AR), A33962-000.....	49
5.4	Sample Program	50

Figures

3-1	Rack Mounting Configuration	8
3-2	TWTA Front Panel Features	11
3-3	Front Panel Display Screens	12
3-4	TWTA Rear Panel Features	16

Tables

3-1	Front Panel Features.....	11
3-2	Rear Panel Features.....	16
3-3	Catalog of IEEE-488 Commands	18
3-4	Catalog of Status Codes	20
3-5	Catalog of Fault Codes.....	20
3-6	Catalog of System State Codes	21
3-7	Catalog of *STA?; Response Codes	21
3-8	Catalog of *STB?; Response Codes.....	22
3-9	Catalog of Heater Auto Off Time Delay Codes.....	22

1. DESCRIPTION AND SPECIFICATIONS

This manual provides operating, interfacing and selected service information pertinent to AR Model 200T18G26z5A and 200T26z5G40A Broadband Microwave Amplifiers. These Models are 200 watt broadband K- and Ka- band traveling-wave tube amplifiers (TWTA) respectively. This manual supports models offering additional special features. Refer to the model specification sheet to determine the applicable features of these units.

1.1 TWTA DESCRIPTION

The amplifier uses two power-combined broadband traveling-wave tubes (TWTs) to provide 200 watts minimum output over the TWT amplifier's full bandwidth. The amplifier is well suited for susceptibility and general laboratory testing where instantaneous bandwidth and high gain are required.

The amplifier is completely self-contained and packaged for standard 19-inch rack mounting or bench top use. The front panel of the rack mountable amplifier is 15.7 inches (9U) high, and the overall unit is 28.4 inches deep, including the rear-panel connectors and vent housing. For bench top use, the amplifier is supplied in an enclosure with integral carrying handles.

Primary power is 190-260 volts 50-60 Hz., single phase. An efficient switching power supply design provides minimum power consumption. A fast regulation control loop and a high degree of filtering ensure performance within specifications over a wide range of operating conditions. The amplifier is fully enclosed, and the upper and lower panels of the rack mountable amplifier are interlocked to reduce the likelihood of accidental contact with high voltage.

1.2 SUGGESTED APPLICATIONS

- RF Susceptibility testing
- Antenna and component testing
- Equipment calibration
- General laboratory instrumentation

1.3 SPECIFICATIONS

Refer to the AR Data Sheet at the end of this section for detailed specifications.

1.4 ACCESSORIES

AR offers a number of accessories for use with this amplifier including:

- Directional coupler
- Antenna
- Flexible transmission line

Refer to a current AR catalog for Microwave Accessories.

1.5 TEST DATA SHEET

A Test Data Sheet for a specific unit is prepared at the time of manufacture and is included with the unit's copy of this manual.



200T26z5G40A

- M1 through M5
- 200 Watts CW
- 26z5GHz-40GHz

Features

The Model 200T26z5G40A is a self contained, forced air cooled, broadband traveling wave tube (TWT) microwave amplifier designed for applications where wide instantaneous bandwidth, high gain and moderate power output are required. A reliable TWT subsystem provides a conservative 200 watts minimum at the amplifier output connector. Stated power specifications are at the fundamental frequency.

The amplifier's front panel digital display shows forward and reflected output plus extensive system status information accessed through a series of menus via soft keys. Status indicators include power on, warm-up, standby, operate, faults, excess reflected power warning and remote. Standard features include a built-in IEEE-488 (GPIB) interface, 0dBm input, VSWR protection, gain control, forward and reflected RF output sample ports, auto sleep, plus monitoring of TWT helix current, cathode voltage, collector voltage, heater current, heater voltage, baseplate temperature and cabinet temperature. Modular design of the power supply and RF components allow for easy access and repair. Use of a switching mode power supply results in significant weight reduction.

The rated power is developed by efficiently power combining the outputs from two 120 watts (nominal) microwave tubes that are factory matched in gain and phase.

Housed in a stylish contemporary cabinet, the unit is designed for benchtop use but can be removed from the cabinet for rack mounting. The Model 200T26z5G40A provides readily available RF power for a variety of applications in Test and Measurement, (including EMC RF susceptibility testing), Industrial and University Research and Development, and Service applications. This sub-octave amplifier features moderate harmonic content.

The export classification for this equipment is EAR99. These commodities, technology or software are controlled for export in accordance with the U.S. Export Administration Regulations. Diversion contrary to U.S. law is prohibited.

See Model Configurations for alternative packaging.

Model 200T26z5G40 Typical Power Output

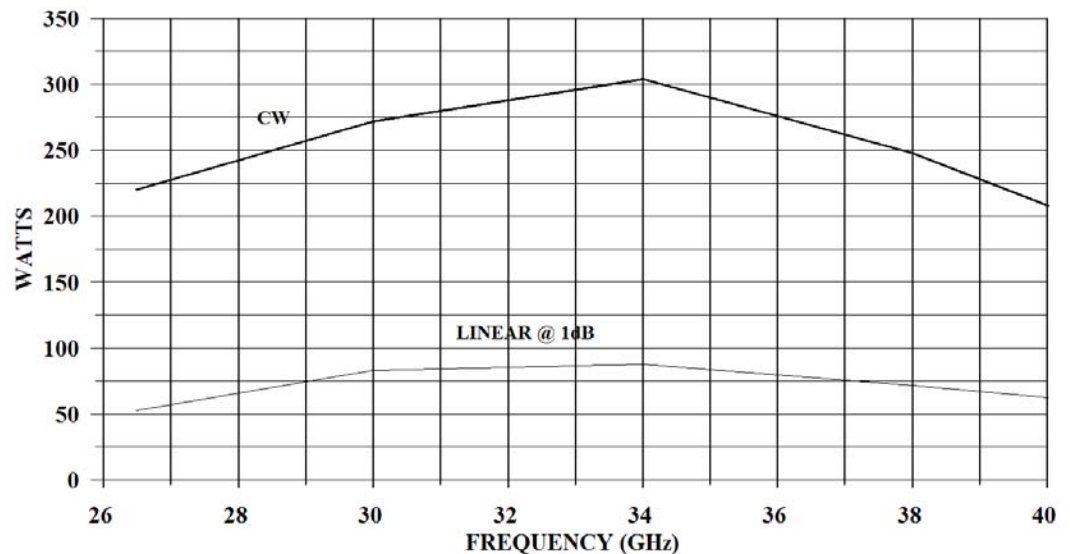

AR RF/Microwave
Instrumentation
160 School House Rd
Souderton, PA 18964
215-723-8181

For an applications engineer call: 800.933.8181

www.arworld.us



200T26z5G40A

- M1 through M5
- 200 Watts CW
- 26z5GHz–40GHz

Specifications

**POWER (fundamental), CW
@ OUTPUT CONNECTOR:**

Nominal	225 watts
Minimum	200 watts
Linear @ 1dB Compression	50 watts minimum

FLATNESS: ±10 dB maximum

FREQUENCY RESPONSE: 26z5–40 GHz instantaneously

INPUT FOR RATED OUTPUT: 1.0 milliwatt maximum

GAIN (at maximum setting): 53 dB minimum

GAIN ADJUSTMENT (continuous range): 35 dB minimum

INPUT IMPEDANCE: 50 ohms, VSWR 2.0:1 maximum

OUTPUT IMPEDANCE: 50 ohms, VSWR 2.5:1 typical

MISMATCH TOLERANCE: Output power foldback protection at reflected power exceeding 40 watts. Will operate without damage or oscillation with any magnitude and phase of source and load impedance. May oscillate with unshielded open due to coupling to input. Should not be tested with connector off.

MODULATION CAPABILITY: Will faithfully reproduce AM, FM, or pulse modulation appearing on the input signal. AM peak envelope power limited to specified power.

VIDEO PULSE CAPABILITY:

Pulse Width	0.1 microseconds min
Pulse Rate (PRF)	10kHz max
Duty Cycle:	Some restrictions apply. Contact AR with application requirements.
RF Rise and Fall	100 ns max (10% to 90%)
Delay	500 ns max from pulse input to RF 90%
Pulse width distortion	200 ns max (50% points of output pulse width compared to 50% points of input pulse width)
Noise Power Density (pulse off)	Minus 140 dBm/Hz (typical)
Pulse Off Isolation	80 dB minimum, 90 dB typical
Pulse Input:	TTL Level, 50 Ohm nominal termination, high level enables RF when video pulsing mode is selected.

NOISE POWER DENSITY:

Minus 70 dBm/Hz (maximum)
Minus 75 dBm/Hz (typical)

HARMONIC DISTORTION:

Minus 20 dBc maximum
Minus 30 dBc typical

PRIMARY POWER: 190-265 VAC, 50/60 Hz, single phase, 3 kVA maximum

CONNECTORS:

RF input	Type K female on rear panel
RF output	Type WR-28 waveguide flange on rear panel
RF output sample ports	Type K female on rear panel
GPIB	IEEE-488 on rear panel
Interlock	DB-15 (f) on rear panel
Video	BNC female on rear panel

COOLING: Forced air (self contained fans), air entry and exit in rear.

WEIGHT: 91 kg (200 lbs)

SIZE: 50.3 x 43 x 81 cm (19.8 x 17 x 32 in)

EXPORT CLASSIFICATION: EAR99

Model Configurations

E	Package Alternatives. May select an alternative from the following [E1C or (E1C and E2S) and/or E3H]:
E1C	Cabinet: Without outer enclosure, size 49 x 40 (9U) x 76 cm, 19 x 15.75 (9U) x 30 in., Subtract approximately 14 kg, 30 lbs, for removal of outer enclosure.
E2S	Slides: slides installed, add approximately 5 lbs, 2 kg.
E3H	Handles: Front handles installed.

Model Number	Features
200T26z5G40A	Base model
M1	E1C
M2	E3H
M3	E1C & E3H
M4	E1C & E2S
M5	E1C & E2S & E3H

Model number example: Model 200T26z5G40AM2 would have option E3H front handles installed.

2. THEORY OF OPERATION

2.1 DESIGN OF THE AMPLIFIER

The TWT amplifier consists of four principal subsystems. Two of these subsystems, the microwave power assembly and the TWT power supplies are discussed in sections 2.2 and 2.3, respectively.

The other two subsystems are the microprocessor control system and the TWTA packaging. These both consist of a number of subassemblies. See the build tree in section 5.1 for further information about how the parts lists are structured.

The heart of the microprocessor control system is the control head assembly, which consists of the CPU board, the HPA display board, and the data link board. The microprocessor control system supervises the power supply, provides metering display, processes operator front panel inputs, and enables communication with a host computer over the IEEE-488 interface.

The control head is provided with its own power supply and, other than thru the IEEE-488 interface bus, is electrically isolated from the amplifier. Communication with the amplifier is via fiber optic links to the HPA interface assembly.

The TWTA packaging consists of two cabinet assemblies secured as one. The cooling system utilizes two 60 Hz fans to cool the HV power supplies and a pair of hi speed 400Hz fans to cool the TWTs.

2.2 DESCRIPTION OF THE RF ASSEMBLY

The TWTA consists of two stages of RF amplification. The first stage is a solid-state preamp assembly with adjustable gain followed by the last stage using a pair of power combined traveling-wave tubes.

The Type K RF input connector is located on the rear panel, or optionally on the front panel depending on configuration. The RF input is fed through an input isolator to the input connector on the solid-state preamp. The solid-state preamp's output drives into a magic tee/splitter assembly that incorporates phase shifters to permit adjustment for optimized phase matching. The two outputs drive the RF input of each TWT. The RF output of each TWT is through a waveguide flange. Each output passes through a reverse directional coupler used to monitor for high reflected power due to excessive load VSWR and/or internal RF component failure. High reflected power will cause a fault and take the unit out of Operate mode.

The output power of both two couplers is combined at a magic tee assembly before being directed through a dual directional coupler. The output coupler provides forward and reverse samples for both monitoring and protection. The reflected port on this directional coupler is routed to a detector diode. The detector output is used for reverse power measurement on the HPA interface board. A sample of the reverse power is optionally located on the front or rear panels.

The forward port of the directional coupler is split with a 10 dB coupler. One output is connected to a detector diode. The output of the detector diode is used on the HPA interface board to measure forward power. The other output is connected to the RF sample port on the rear panel or, optionally, on the front panel depending on configuration. The coupler waveguide terminates in a WR-42 waveguide flange in the 18G26 and WR-28 waveguide flange in the 26G40 that protrudes through the rear panel of the TWTA.

Amplifier gain is determined by a single solid-state preamp (SSPA), which has a voltage-controlled attenuator. The control head determines the output of a digital-to-analog converter (DAC) on the HPA interface board. The output of the DAC controls the SSPA attenuator.

2.3 DESCRIPTION OF THE POWER SUPPLY

The two TWT power supplies are of modular construction. The low voltage power supply modules provide low voltage power for logic and control of all power supply assemblies. In addition these modules provide DC power for the HPA interface. Control logic and TWT protection circuits are contained in the HPA Logic and Control Assemblies.

Each high voltage power supply consists of the following: the Power Factor Correction module converts line voltage to DC for the high voltage switching supply. Switching transistors, controlled by the Pulse Width Modulation (PWM) Board, are on the Power Board Assembly. The high voltage transformer and rectifiers are contained in the High Voltage Diode/Cap Assembly. The high voltage DC is filtered in the HV Filter Assemblies. The same Focus Electrode Modulator is used on both the 18G26 and the 26G40 models.

Low voltage interconnects between the power supply modules are through a motherboard. It is installed in a finned heat sink assembly to which the modules are bolted. Incoming cabinet air-cools the heat sink.

3. OPERATION

3.1 WARNINGS AND CAUTIONS

Throughout this manual, the symbol:



WARNING:

Indicates that a hazard exists that may result in personal injury or loss of life.



CAUTION:

Indicates that failure to follow procedures may result in damage to the equipment.



WARNING: DANGER - High Voltage Present:

Electrical equipment in this TWTA generates and stores high-voltage energy that can result in fatal electrocution. Do not operate the TWTA with covers or the front panel removed.

Only technicians thoroughly familiar with the high-voltages present in microwave tube amplifiers must perform Service work in general, and with this equipment in particular.

Never handle the TWT leads or the high-voltage connectors unless the unit has been unplugged and it has been positively established that the high-voltage filter capacitors have been discharged to a *known* safe level.



WARNING: Safety Ground

Improper grounding of this equipment can result in electric shock. The TWTA must be operated only with a line cord with a safety ground wire. It is the user's responsibility to ascertain that the power connector is properly wired and that the power outlet is grounded.



WARNING: Explosive Atmosphere

To avoid explosion, never operate this TWTA in an explosive atmosphere. This equipment is not certified for operation in an explosive atmosphere.

3.2 INSTALLATION

3.2.1 Unpacking

Upon receiving the TWTA, unpack the unit and inspect it for obvious signs of external damage. If damage is observed, notify the carrier and contact an authorized service representative.

Save and store the shipping container in case the unit needs to be returned in the future for calibration or repair.

3.2.2 Mounting

The TWTA may be operated as a standalone bench top unit or it may be installed in a 19" rack.

If rack mounting is desired, first remove the amplifier from the cabinet, then install the amplifier in the rack.



CAUTION:
Due to the weight of the unit, the removal of the amplifier from the cabinet or rack is a two-person operation.

Before removal disconnect power, RF, and any other interface connectors. On the rear of the unit, remove the six screws used to connect brackets to amplifier. On the front of the unit, remove the four screws holding each the front panel to the cabinet. Carefully slide the amplifier out of the front of the cabinet.



CAUTION:
Never rack mount the TWTA using the front panel alone. The chassis is likely to be damaged unless its weight is supported. Bottom support rails must be provided in a rack mount configuration.

See Figure 3-1 for the locations of threaded holes on the bottom half of the TWTA chassis, which may be used for supplementary support of the TWTA.

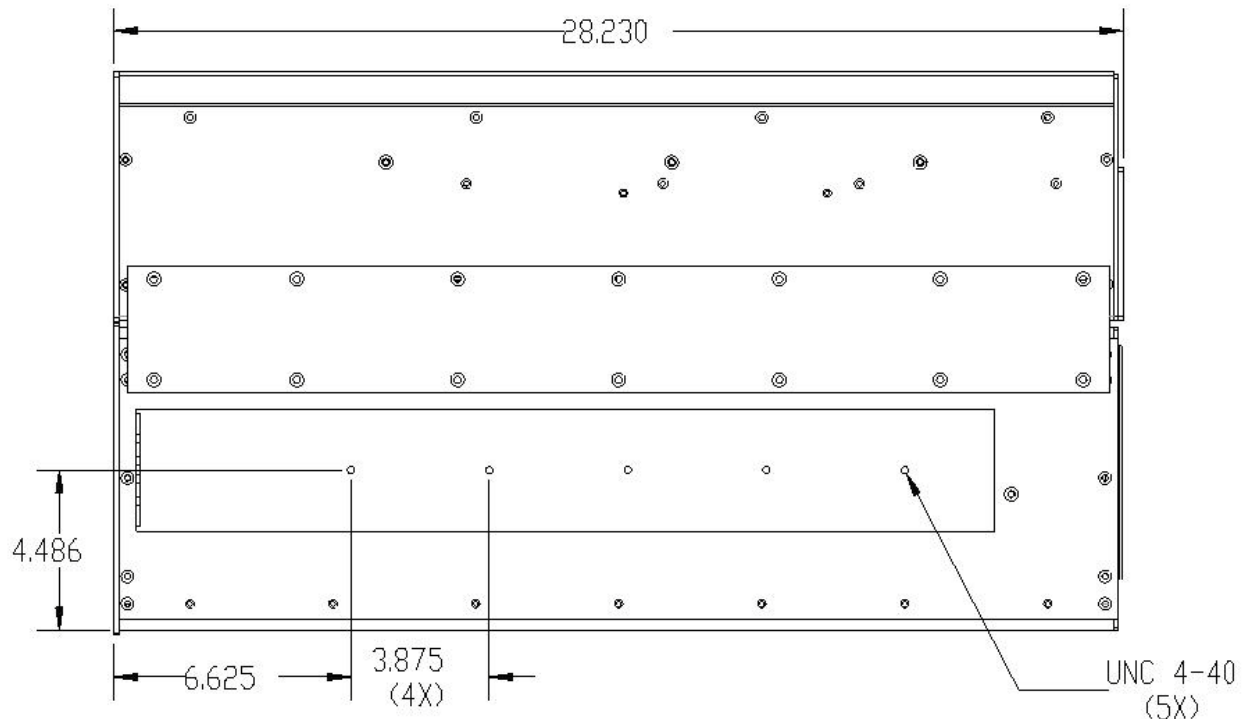

Figure 3-1. Rack Mounting Configuration

If bottom supports are used for rack mount installation of multiple units, the amplifiers should be separated vertically by at least 1 3/4 inches. This will allow room for necessary support rails and facilitate installation and removal of the units.

3.2.3 Cooling Requirements

The TWTA is provided with two cooling fans. It is important that air movement around the rear of the unit be unobstructed.



CAUTION:

For either bench or rack mounting, do not position the TWTA in such a way that the air intakes or outlets are blocked, or that the exhaust flows are directed into the intakes. See Paragraph 3.5 for location of air intakes and air outlets. If the unit is rack mounted, make sure that the intake air is 45°C or below. If necessary, fabricate short ducts to direct the hot exhaust air out of the rack enclosure. Great care must be taken to minimize any flow restrictions. Avoid mounting heat-producing equipment in the same rack, especially below the TWTA. Failure to provide adequate cooling can result in the unit's shutting down from over temperature conditions.

The TWTA dissipates approximately 1500 watts when in the operate mode.

3.2.4 AC Line Power Connections

The AC line power connection to the TWTA is made at the AC inlet J1, which is a female IEC-320 16A connector. The power inlet receptacle is provided with a clamp that can be used to secure the mating plug from accidental withdrawal. A line cord with AC plug suitable for the type of AC outlet used and consistent with local electrical codes must be used to mate with J1. Minimum wire size recommended for the line cord is 1.5 mm² (16 AWG).

Units are provided with an un-terminated 3-wire cord. To use this line cord it should be terminated with a suitable plug to a 190 to 260 VAC 50-60 Hz. single-phase source as follows:

Color		Function
International Harmonized	North American	
Brown	Black	Line
Blue	White	Neutral
Yellow/Green	Green	Safety Ground

CAUTION:



Connect plug to J1 and secure plug with bracket only when no AC is supplied to the cord.

3.2.5 RF Output Connections

The RF output connection is a WR-42 waveguide flat flange in the 200T18G26z5A. The RF output connection is a WR-28 waveguide flat flange in the 200T26z5G40A. Output flange alignment is critical for proper operation. Align the two flanges and secure the mating waveguide while maintaining flange alignment.

**CAUTION:**

Never operate the TWTA without a matched output load rated for at least 300 watts, continuous. Full reflected power may irreparably damage the TWT. Even with no drive, “looping” oscillation can result in RF output high enough to damage the tube if it is operated without a load. The VSWR detection, isolator and foldback circuit is provided to protect the tube from *progressive* failure or mismatch of the output load; it should not be relied on for protection from the absence of a load.

If an external isolator is installed at the output of the TWTA, either the isolator should have a load capable of dissipating the full output of the TWTA or the isolator load should be provided with a temperature sensing switch. The temperature switch should be normally closed, self-resetting, and with a temperature rating such that there is no possibility of damaging the load by overheating before the switch opens. The TWTA may be interlocked with the switch by connecting it between pins 3 and 4 of the external interlock connector (J2). If no external isolator is used, install a jumper between pins 3 and 4. See section 3.2.6, External Interlock Connector, below.

3.2.6 External Interlock Connector

The TWTA is provided with an external interlock capability via a 15-pin female D-sub connector, J2. To enable the high voltage power supply, it is necessary to provide continuity between J2 pins 3 and 4. If the amplifier shuts down because the interlock was opened, it will be necessary to reset the system to return to standby (see *System shutdown screen* in Section 3.4). There is an internal jumper between J2 pins 1 and 2; a continuity check through these pins can be used to verify the presence of the amplifier in the instrumentation system. Users may adopt this interlock feature to disable the RF output for either equipment protection or as a backup for personnel protection.

Pin	Title	Function
1	INTERNAL JUMPER	Internal jumper from pin 1 to pin 2
2.	INTERNAL JUMPER	Internal jumper from pin 1 to pin 2
3.	EXTERNAL INTERLOCK SUPPLY	Disables High Voltage power supply in continuity is opened from pin 3 to pin 4.
4.	EXTERNAL INTERLOCK RETURN	Disables High Voltage power supply in continuity is opened from pin 3 to pin 4.
5-9.	NOT USED	
10.	INHIBIT SUPPLY	Disables RF power output if continuity is opened from pin 10 to pin 15.
11-14	NOT USD	
15	INHINIT RETURN	Disables RF power output if continuity is opened from pin 10 to pin 15.

CAUTION:

Do not rely on the external interlock for personnel protection. The intent of the external interlock feature is to disable the RF output for equipment protection. Use proper operating and safety procedures to insure that power is removed for personnel safety.

3.2.7 External IEEE-488 Connector

The TWTA is provided with a standard IEEE-488 connector on the rear panel. If the TWTA is mounted in a bench-top cabinet, the mating connector should be a straight-entry cable type, not a side-entry type.

3.3 FRONT PANEL FEATURES

Refer to Figure 3-2 below.

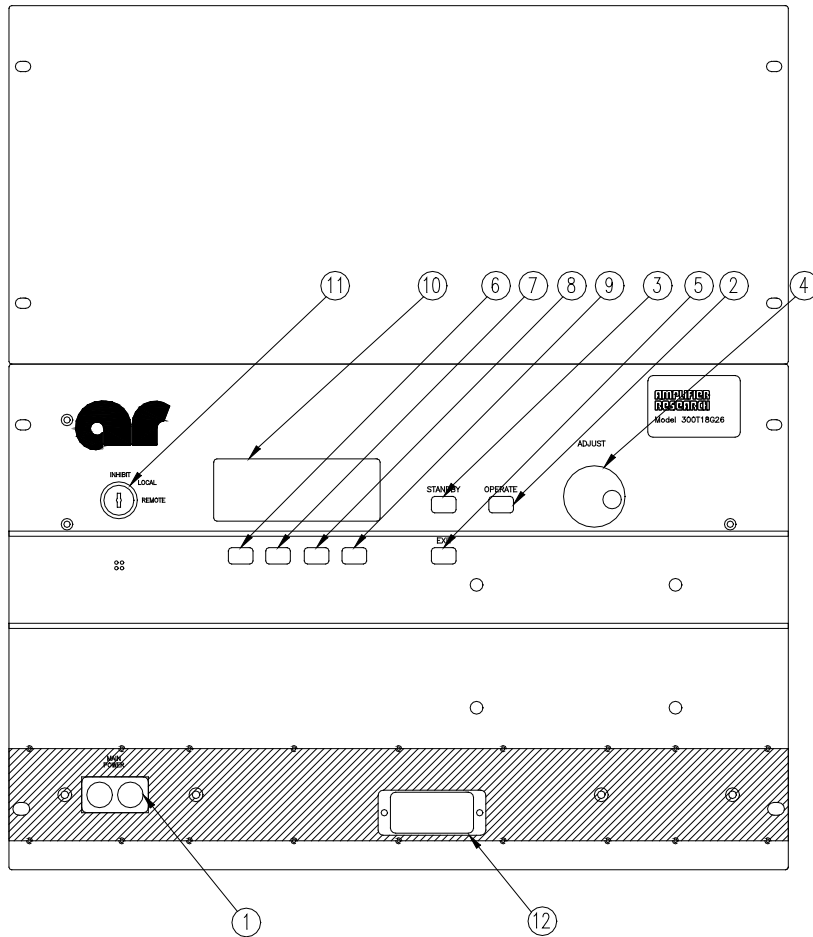

Figure 3-2. Front Panel Features

Table 3-1. Front Panel Features

Item	Title	Function
1	MAIN POWER	Switchable 16 A. circuit breaker; Turns ON/OFF system power.
2.	OPERATE	Push-button; turns on high voltage and SSA when all faults and heater delay are cleared.
3.	STANDBY	Push-button; shuts off SSA and turns off high voltage.
4.	ADJUST	Rotary knob used as an input device to change values of a variety of parameters.
5.	EXIT	Push-button; terminates various menu selection routines and returns to the previous menu level.
6-9.	S1...S4	Soft Key push-buttons; various menu selection functions.
10.	Display	Displays numerous parameter values and fault messages.
11.	Key lock Switch	Allows operator to inhibit the TWTA, to enable front panel control, or to enable computer control.
12.	Forward Fold back Access Cover	Allows access to the forward fold back circuit. Green LED lit when active.

3.4 FRONT PANEL DISPLAY AND SOFT KEYS

The purpose of the front panel display is to permit the operator to access extensive information about the condition and operation of the TWTA. To accomplish this, a number of informational screens are programmed. It is important for the operator to be able to select the screen with the required information. Screen selection is accomplished by pressing an appropriate soft key or by pressing the EXIT key. When a soft key is active, its function is displayed on the bottom line of the display. Figure 3-3 provides a “roadmap” for navigating between the screens.

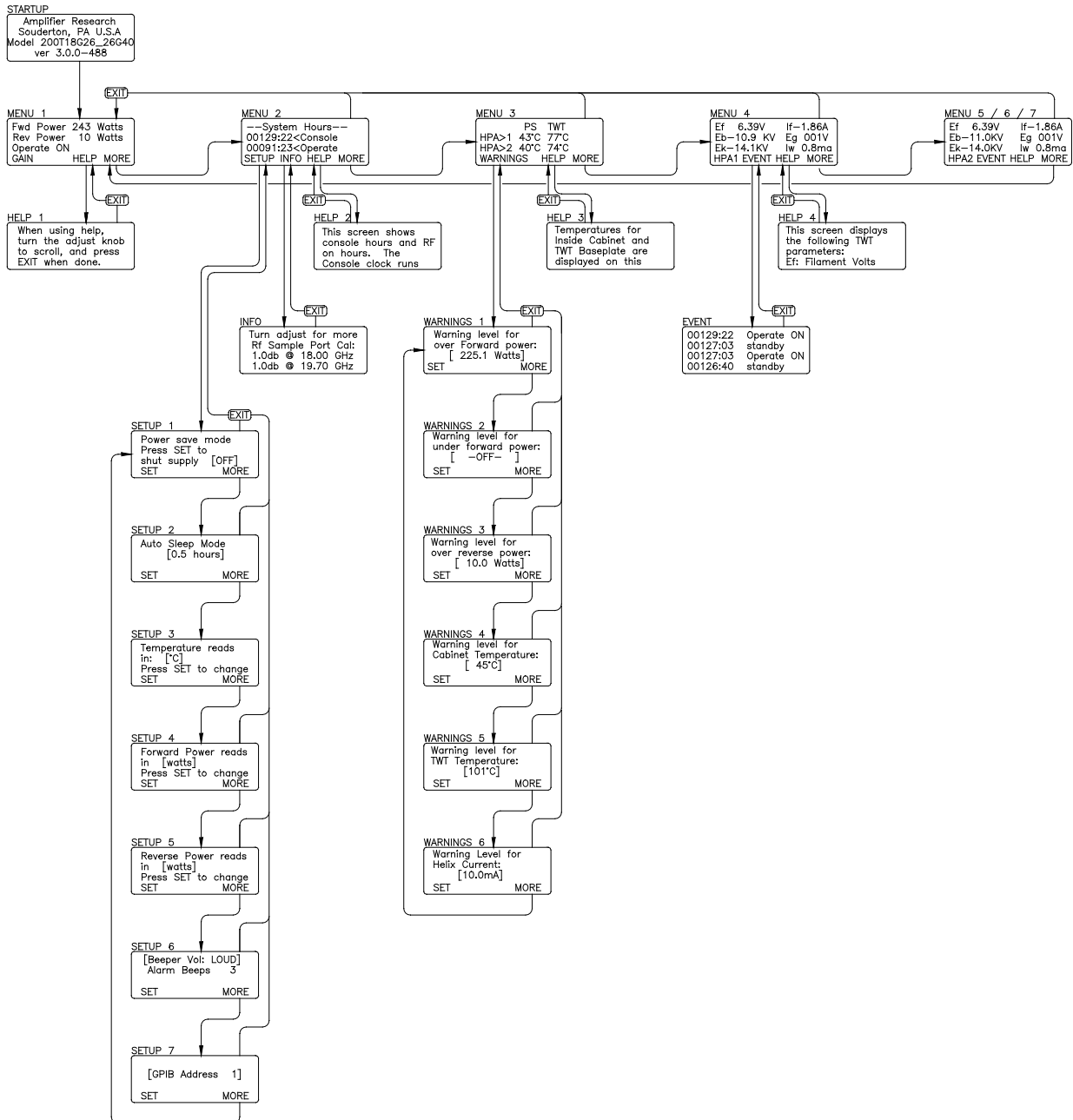

Figure 3-3. Front Panel Display Screens

Menu screens - The screens at the highest level are called menu screens. There are seven menu screens. At power on, the MENU 1 screen is displayed. Each of the menu screens has the soft key S4 labeled MORE. The MORE key (S4) causes the next menu screen to appear. From MENU 7, MORE causes MENU 1 to reappear. In short, MORE permits scrolling through the menu screens. The EXIT key returns display to MENU 1 from any other menu screen.

The menu screens display system status and parameter levels. They are configured as follows:

MENU 1	Forward power (watts, dBm or bar graph)
	Reverse power (watts, dBm or % of forward power)
	System status (if a latched fault exists, MENU 1 is displayed with the system shutdown message)
MENU 2	Console hours (active when AC power is on)
	Operate hours (active when HV is on)
MENU 3	Power Supply temperature (°C or °F)
	TWT baseplate temperature (°C or °F)
MENU 4	Heater voltage (Ef), HPA #1
	Heater current (If), HPA #1
	Collector voltage (Eb), HPA #1
	Grid voltage (Eg), HPA #1
	Cathode voltage (Ek), HPA #1
	Helix current (Iw), HPA #1
MENU 5	Heater voltage (Ef), HPA #2
	Heater current (If), HPA #2
	Collector voltage (Eb), HPA #2
	Grid voltage (Eg), HPA #2
	Cathode voltage (Ek), HPA #2
	Helix current (Iw), HPA #2

Help Screens - On each of the menu screens, soft key S3 is labeled HELP. If S3 is selected, a message describing the functions of that screen will be displayed. Use the ADJUST knob to scroll through the message. The EXIT key will return you to the screen from which the help screen was called.

Setup Screens - From MENU 2, S1 (labeled SETUP) selects the first of several setup screens, SETUP 1. This allows the user to manually shut off the heater power supply and put the HPA into Sleep Mode (see below). Pressing S1 (SET) toggles between On and OFF. Pressing MORE again brings up the SETUP 2 screen, which allows the user to change the Auto Sleep Mode timer setting. Pressing SET will change the timer options in half hour increments from 0.5 to 3.0 hours. Pressing MORE again will save the timer setting and bring up the SETUP 3 screen, which toggles the display of temperature parameters between Fahrenheit and Celsius degrees. Pressing S1 (SET) changes the selection. The setting displayed when the screen is exited will be retained. Pressing MORE again brings up the SETUP 4 screen, which allows a choice of displaying forward power in watts, dBm or bar graph. Pressing MORE a third time brings up SETUP 5, which allows a choice of watts, dBm, or % of forward power for displaying reverse power. MORE brings up SETUP 6, which allows entering the desired number of alarm beeps and the desired beep volume. S1 (SET) toggles between parameters, and the adjust knob is used to enter the data. Setup 7 allows the IEEE-488 address to be set. MORE returns you to SETUP 1. EXIT returns you from any of the setup screens to MENU 2.

Sleep Mode - The Sleep Mode feature allows the *user* to selectively shut off the heater module of the power supplies. This can be done manually through the front panel or remotely via the computer interface. This is typically used during extended periods of *remote* operation to improve tube life, by turning off the filaments (Sleep Mode activated). This eliminates excessive STANDBY hours on the TWTs while still permitting remote capability to turn on the amplifier.

To activate Sleep Mode locally: Press the MORE soft key to get to MENU 2. At MENU 2 press the SETUP soft key to get to SETUP 1. At SETUP 1 press SET to activate Sleep Mode (turn heater and fan off). The system will ask **are you sure?** Press SET again.

After activating the Sleep Mode: Screen will display **Cooling On** while heaters cool down. **System Off** notifies user that the amplifier is in Sleep Mode

To deactivate Sleep Mode locally: Press the ON soft key to de-activate Sleep Mode. Amplifier will return to MENU 1. When de-activating the Sleep Mode the heaters will require approximately a 3 minute heater time delay. Wait the full 3 minutes prior to selecting OPERATE.

For remote activation of Sleep Mode or to set the Auto Sleep Mode timer remotely see Table 3-3 in Section 3.8.

Warnings Screens - From MENU 3, S1 (labeled WARNINGS) selects WARNINGS 1, which allows the operator to enter the maximum forward power. The existing value is between brackets[]; pressing SET puts arrows >< around the value, indicating that the adjust knob is active. The effect of the warning set point is as follows: if the forward power exceeds the set point, the audible alarm will sound (if configured in SETUP 3).

This warning will be repeated every thirty seconds until the over forward power condition is cleared. In addition, a warning message will appear on line 3 (the status line) of MENU 1. In the event that the alarm is heard, the operator should go to MENU 1 to determine the cause.

Pressing more brings up WARNINGS 2, which allows the under forward power set point to be entered. Adjusting this to the minimum value causes -OFF- to be selected, disabling this alarm.

In WARNINGS 3, the maximum reverse power level is set. Note that these are warning levels at which the beep sounds; the actual maximum reverse power level that generates a system fault is set in hardware in the TWT power supply HPA Logic and Control module (A16485).

MORE brings up WARNINGS 4, which allows input of the maximum cabinet temperature. Entering this parameter is performed as above.

MORE brings up WARNINGS 5, identical to the previous screen except that it deals with the maximum TWT collector block temperature. If either parameter exceeds the set point, the audible alarm will sound every 30 seconds (if configured), and a warning message will appear on line 3 of MENU 1.

From WARNINGS 5, MORE brings up WARNINGS 6, which permits setting the maximum helix current. Any helix current above this set point will result in an audible alarm (if configured), repeated every 30 seconds; and a warning message is displayed on the status line of MENU 1.

Pressing MORE again returns display to WARNINGS 1. As before, pressing EXIT from any of the warnings screens returns display to MENU 3.

Info Screen - From MENU 2, S2 (labeled INFO) selects a screen that displays the RF sample port calibration factors at various frequencies across the band. In addition, this screen displays the model number, serial number and firmware revision information, which may be required by a service representative when providing technical assistance. The EXIT key returns the display to MENU 2.

Event Screen - From MENU 4, S2 (labeled EVENT) provides a display of events logged by the control system. These events include AC power-up, heater warm-up, change from standby to operate, faults, and resets. The events are stored in a first-in-first-out (FIFO) software buffer that has room for 100 events; as new events are logged, the older ones are discarded.

System Shutdown Screen - In the event of a system shutdown due to a latched fault (i.e., a fault such as body overcurrent or power low line that requires a reset), the MENU screen is replaced by a screen indicating the nature of the fault. Softkey S4 (labeled OK) is implemented as a reset key; pressing S4 brings back the MENU screens. Line 3 of MENU 1, which normally displays the operational state of the TWTA, is used as a fault display line until the fault is cleared. When the fault clears the system will automatically resume the standby state and high voltage on will be enabled once again.

Factory Service Screens - A number of screens intended for factory service and calibration are behind passwords and are not accessible to the user.

System Malfunction Screens - A number of screens are reserved to display error messages. These messages are not normally seen and indicate a malfunction of the TWTA. System malfunction messages include the following:

- Database corrupt
- Communication failure
- Cannot restore
- CU line voltage too low to operate. System shutdown

In the event that one of these appears, shut off the TWTA and contact an authorized service representative before proceeding.

CAUTION:



Attempts to operate the TWTA despite control unit problems may result in loss of the static RAM database and calibration information.

3.5 REAR PANEL FEATURES

See Figure 3-4 below.

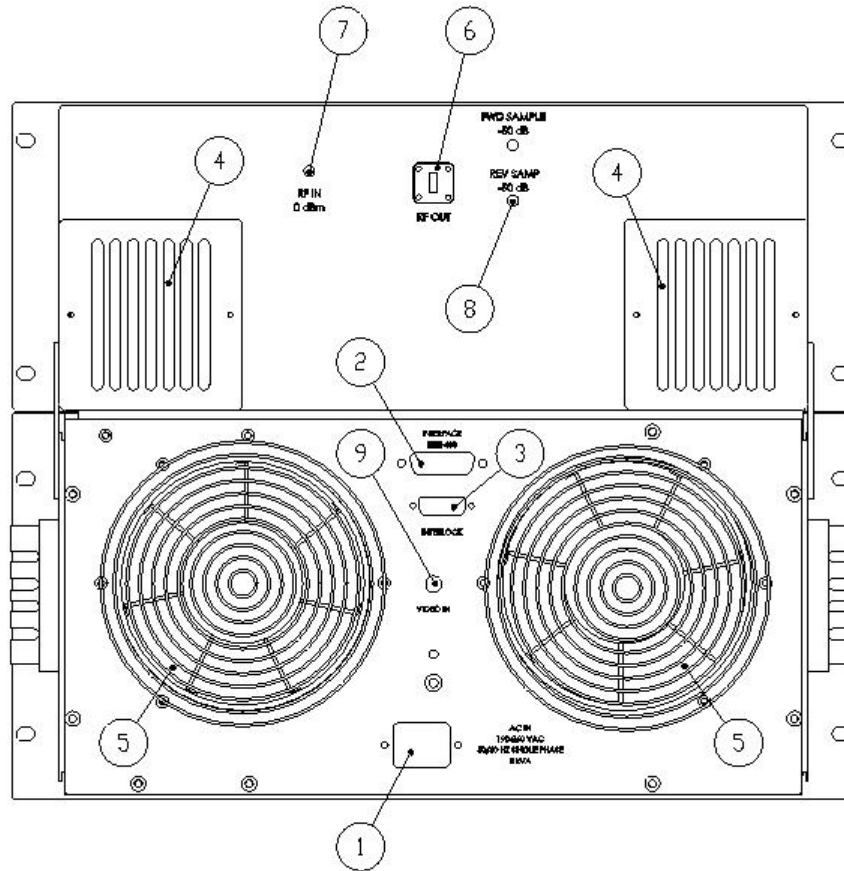

Figure 3-4. Rear Panel Features

Table 3-2. TWTA Rear Panel Features

Item	Title	Function
1.	AC POWER IN	AC power input connector: MS 3102R-18-10P connector
2.	IEEE-488	Remote control connector: 24 pin hermaphrodite
3.	EXTERNAL INTERLOCK	Connector to remote temperature switch protecting the isolator load: D-sub 15-pin female
4.	—	Cooling air intake.
5.	—	Cooling air outlet.
6.	RF OUTPUT	RF output: Model dependant
7.	RF INPUT	RF input; Type K connector (on rear panel connector configurations)
8.	FORWARD SAMPLE	RF forward power sample; Type K connector (on rear panel connector configurations)

3.6 INITIAL TURN ON AND WARM-UP PROCEDURE

Install the TWTA as discussed in section 3.2. Connect a suitable RF generator to the RF input Type K connector. Set RF generator level below -50 dBm and set desired frequency in specified range. Connect a load suitable for 300 watts continuous operation to the output waveguide flange. The load VSWR should be less than 2.0:1

A power meter and suitable attenuators may be connected to the RF forward sample port. (Refer to RF sample port calibration factors on the rear of the unit or on the *Info* screen in MENU 2 or in the test data sheet provided with this manual). These show the relation between the amplifier output power and the RF sample port power as a function of frequency. When only the power of the fundamental frequency is to be measured and when operating near rated power use; filters, a frequency selective receiver, or a spectrum analyzer to reduce the harmonic content of the measured level.

Set keylock to LOCAL.

Switch on the MAIN POWER circuit breaker. The fans will operate. The front panel display will show several identification messages and then the MENU 1 screen. The third line will indicate that the heater time delay is active.

Allow the heater warm-up delay to expire. Line three will indicate OFF/READY.

Push S4 (MORE) three times to go to MENU 4. Verify that the heater voltage and current are near their nominal levels. The values of these parameters at the time the TWTA left the factory are logged on the test data sheet.

Push the OPERATE push-button. You will now see the cathode and the collector voltages rise. Verify that the collector and cathode voltages are near nominal. The helix current should be close to the nominal value for no RF drive. Then push MORE or EXIT to go back to MENU 1.

Set the TWTA gain to maximum. Adjust the RF generator to slowly increase the RF drive toward 0 dBm to reach the desired FWD PWR on the display and power meter (connected to sample port). The forward power indication will become active, with maximum reading when the peak power output is achieved. Best performance is obtained when the input RF drive is set at or just below the level that causes peak power output. Do not set input drive above 0 dBm (Input drive above +13 dBm may damage the unit). The reverse power level should remain below 10% of the forward power, assuming that the load is properly matched.

An alternate procedure is to pre-set the TWTA gain to minimum, set the RF generator to 0 dBm and then slowly increase the TWTA gain to set the desired RF output level.

Observe that the helix current is sensitive to the RF drive level of the TWT. It is at a minimum with no RF drive. The helix currents with no drive and with rated RF output mid-band are logged on the test data sheet. The value of the helix current is a good qualitative indicator of RF drive present.

To shut the system down, turn down the RF generator level below -50 dBm and press STANDBY. Allow the TWTA to cool down until the TWT temperature drops below 70°C, then turn off main power

3.7 FOLDBACK OPERATION

Forward FOLDBACK and reverse FOLDBACK circuits are used on both the 18G26z5 and 26z5G40. In the event the output power exceeds or the reflected power exceed factory limits a fold back circuit will active, and control the solid-state amplifier attenuation to ensure the output power is kept to fixed limit.

Forward Fold back

The forward FOLDBACK protection circuit will activate if RF output power exceed 250W. The TWT display screen will flash “FOLDBAK ACTIVE” warning. The cover plate on the front panel allows access to the forward fold back circuit. The limits are set at the factory and do not require adjustments.



CAUTION:
Do not adjust 20-turn pot R11; its function is to set the Forward foldback VSWR level, and it is calibrated at the factory.

Reverse Fold back

The reverse FOLDBACK protection circuit will active if the reflected power exceeds 20W. The TWT display screen will flash “FOLDBAK ACTIVE” warning. The reverse fold back is located internally to the machine on A32363-000 VSWR & FOLDBACK board assembly.

3.8 REMOTE IEEE-488 OPERATION

The TWTA is provided with an IEEE-488 interface that permits remote emulation of OPERATE, STANDBY, and RESET push-buttons as well as access to parameter measurements, system faults, gain adjustment and control unit status. The following tables summarize the commands and the return codes.

Table 3-3. Catalog of IEEE-488 Commands

Command	Function	Units	Response format
RDSTAT	Returns status code of processing of previous command (see Table 3-4)		STATUS=[]
RDFLT	Returns system fault code (see Table 3-5)		flt=[]
OPERATE;	Emulates OPERATE push-button		
STANDBY;	Emulate STANDBY push-button		
POWER:OFF;	Emulate STANDBY push-button		
SYSTEM:ON;	Emulates pressing the System ON button from System OFF (Exit Sleep Mode)		
SYSTEM:OFF;	Emulates pressing the Power Save button. (Enter Sleep Mode)		
RESET;	Emulates RESET softkey		
RDS/N	Returns serial number		s/n=[]
RDCONHR	Returns console hours		ConHr=[]
RDRFHR	Returns RF hours		RfHr=[]
RDEK1	Returns cathode voltage, HPA1	KV	Ek=[]
RDEK2	Returns cathode voltage, HPA2	KV	Ek=[]
RDEB1	Returns collector voltage, HPA1	KV	Eb=[]
RDEB2	Returns collector voltage, HPA2	KV	Eb=[]
RDEG1	Return grid voltage, HPA1	V	Eg=[]
RDEG2	Return grid voltage, HPA2	V	Eg=[]

Command	Function	Units	Response format
RDEF1	Returns heater voltage, HPA1	V	Ef=[]
RDEF2	Returns heater voltage, HPA2	V	Ef=[]
RDIF1	Returns heater current, HPA1	A	If=[]
RDIF2	Returns heater current, HPA2	A	If=[]
RDIW1	Returns helix current, HPA1	mA	Iw=[]
RDIW2	Returns helix current, HPA2	mA	Iw=[]
RDTMPTWTHPA1F	Returns TWT temp (°F), HPA1	°F	TWTHPA1F=[]F
RDTMPTWTHPA2F	Returns TWT temp (°F), HPA2	°F	TWT HPA2F=[]F
RDTMPTWTHPA1C	Returns TWT temp (°C), HPA1	°C	TWTHPA1C=[]C
RDTMPTWTHPA2C	Returns TWT temp (°C), HPA2	°C	TWTHPA2C=[]C
RDTWTOTF	Returns TWT overtemp warning setpoint (°F)	°F	TWTOTF=[]F
STWTOTF	Sets TWT overtemp warning setpoint (°F)	°F	
RDTWTOTC	Returns TWT overtemp warning setpoint (°C)	°C	TWTOTC=[]C
STWTOTC	Sets TWT overtemp warning setpoint (°C)	°C	
RDIWOC	Returns helix overcurrent warning setpoint	mA	IwOC=[]
SIWOC	Sets helix overcurrent warning setpoint	mA	
RDLOGIC	Returns logic state code (see Table 3-6)		Sys=[]
RDA	Returns gain	%	A=[]
SA	Sets gain	%	
RDHTDREM	Returns remaining heater time delay	sec.	HTD=[]s
RDPOD	Returns forward power out (dBm)	dBm	Po=[]dBm
RDPOW	Returns forward power out (W)	watts	Po=[]W
RDPRD	Returns reverse power out (dBm)	dBm	Pr=[]dBm
RDPRW	Returns reverse power out (W)	watts	Pr=[]W
RDPOHID	Returns over forward power warning setpoint (dBm)	dBm	Pohi=[]dBm
SPOHID	Sets over forward power warning setpoint (dBm)	dBm	
RDPOLOD	Returns under forward power warning setpoint (dBm)	dBm	Polo=[]dBm
SPOLOD	Sets under forward power warning setpoint (dBm)	dBm	
RDPOHIW	Returns over forward power warning setpoint (W)	watts	Pohi=[]W
SPOHIW	Sets over forward power warning setpoint (W)	watts	
RDPOLOW	Returns under forward power warning setpoint (W)	watts	Polo=[]W
SPOLOW	Sets under forward power warning setpoint (W)	watts	
RDPRHID	Returns over reverse power warning setpoint (dB)	dBm	Prhi=[]dBm
SPPRHID	Sets over reverse power warning setpoint (dBm)	dBm	
RDPRHIW	Returns over reverse power warning setpoint (W)	watts	Prhi=[]W
SPRHIW	Sets over reverse power warning setpoint (W)	watts	
RDHTRAUTOOFF	Returns heater to auto off delay	hours	
SHTRAUTOOFF	Sets heater auto off delay (see Table 3-9)		
*IDN?;	Returns the product model number		[]
*STA?;	Returns status string (see Table 3-7)		[]
*STB?;	Returns status string (see Table 3-8)		[]

Table 3-4. Catalog of Status Codes

(The **RDSTAT** command causes the TWTA to return a string in the form **STATUS=[code]**, where **[code]** is an ASCII number whose meaning is given below)

Status Code	Meaning
0	No command was given.
1	Last command successful.
2	Last command is in process.
3	Last command failed to complete. Time-out.
10	Last command failed. Invalid command.
11	Last command failed. Data was unparseable.
20	Last set command failed. Data was beyond high limit.
21	Last set command failed. Data was beyond low limit.
22	Last set command failed. Data was out of range
23	Last set command failed. Data was wrong polarity
50	Last command failed. Local system does not have remote enabled.
51	Remote system is not ready to accept commands.
60	Command not allowed
901	Assert error: invalid table argument *
902	Assert error: invalid table argument *

* Please call a service representative if you observe this error.

Table 3-5. Catalog of Fault Codes

(The **RDFLT** command causes the TWTA to return a string in the form **flt=[code]**, where **[code]** is an ASCII number whose meaning is given below)

Fault Code	Meaning	Fault Code	Meaning
0	No fault	26	Panel Open
7	SYSTEM FAULT1	39	SYSTEM FAULT2
8	FIL NOT READY1	40	FIL NOT READY2
9	LOW LINE1	41	LOW LINE2
10	CATH O/VOLTAGE1	42	CATH O/VOLTAGE2
11	BODY O/CURRENT1	43	BODY O/CURRENT2
12	CATH U/VOLTAGE1	44	CATH U/VOLTAGE2
13	OUTPUT OVER REV	45	TWT1 OVER REV
15	COLL U/VOLTAGE1	46	TWT2 OVER REV
16	INVERTER FAULT1	47	COLL U/VOLTAGE2
17	INTERLK OPEN1	48	INVERTER FAULT2
18	TUBE ARC1	49	INTERLK OPEN2
19	TWT OVER TEMP1(h)	50	TUBE ARC2
20	CABINET O/TEMP1(h)	51	TWT OVER TEMP2(h)
22	EXTERNAL INHIBIT	52	CABINET O/TEMP2(h)
23	OVER REV POWER1	54	EXTERNAL INHIBIT
55	OVER REV POWER2		

Table 3-6. Catalog of System State Codes

(The **RDLOGIC** command causes the TWTA to send a string containing an operational state code consisting of 4 ASCII characters representing hex digits. The response is in the form **Sys:[w][x][y][z][eol]** where the hex values of **[w],[x],[y]** and **[z]** are formed as shown below)

z bit	Meaning
0 (LSB)	High voltage on
1	Transmit on
2	Remote mode
3 (MSB)	Fault

y bit	Meaning
4 (LSB)	Heater time delay expired
5	Under forward power warning
6	Foldback active
7 (MSB)	Inhibit mode

x bit	Meaning
8 (LSB)	External inhibit
9	Interlock open
10	(not used)
11 (MSB)	(not used)

w bit	Meaning
12 (LSB)	(not used)
13	Sleep Mode Active
14	(not used)
15 (MSB)	(not used)

Table 3-7. *STA?; Response Codes

(The command ***STA?;** causes the TWTA to send a string indicative of the current system state)

*STA?; response	Meaning
SLEEP	Sleep Mode active (heater off)
WARM-UP	System is in heater time delay.
STANDBY	System is ready to allow high voltage on
OPERATE	High voltage is on and beam is on
FAULT	High voltage is off and system requires reset

Table 3-8. *STB?; Response Codes

(The command ***STB?**; causes the TWTA to send a string containing an operational state code consisting of 2 ASCII characters representing hex digits. The response is in the form **STATUS:[x][y][eol]** where the hex values of *[x]* and *[y]* are formed as shown below)

y bit	Meaning
0 (LSB)	Power status; always 1 (power on)
1	Standby status; 0 if not in standby, 1 if in standby
2	Operate status; 0 if not in operate, 1 if in operate
3 (MSB)	Fault status; 0 if no fault, 1 if fault exists
x bit	Meaning
4 (LSB)	Mode switch; always 1 (reset)
5	Blank switch; always 1 (off)
6	Blank status; always 0 (off)
7 (MSB)	Not used; always 0

Table 3-9. Catalog of Heater Auto Off Time Delay Codes

Argument	Meaning
0	0.5 hour heater auto off time delay
1	1.0 hour heater auto off time delay
2	1.5 hour heater auto off time delay
3	2.0 hour heater auto off time delay
4	2.5 hour heater auto off time delay
5	3.0 hour heater auto off time delay

Command syntax is in this form:

<command mnemonic> <parameter> <carriage return>

where;

<command mnemonic> consists of one of any valid command found in Table 3-3.

<parameter> (as applicable) consists of one ASCII space character followed by a number.

<carriage return> consists of an ASCII carriage return.

All commands are case sensitive.

The system will return parameter values, fault codes, and status codes regardless of whether remote is enabled. The parameter value is returned as a string of 20 characters or less, consisting of a label, =, and a value. For example, outputting the command RDEF to the TWTA would result in the TWTA sending back the string **Ef=6.03** (assuming the heater voltage is 6.03 volts). Units are usually not returned; see table 3-3 for the units.

If remote is not enabled, set commands and commands to the system logic (i.e., OPERATE;, STANDBY;, or RESET;) will not be accepted.

It is recommended that the RDSTAT command be used to provide the host program with a report on how a command was processed.

A small sample program that can send commands and receive the strings returned by the TWTA is included in section 5.4. It is written in Hewlett-Packard's "Rocky Mountain" BASIC. The program assumes that the IEEE-488 bus is at address 7 and that the address of the TWTA is 01.

Remote operation is determined by the application (software) program in the system controller. This application program will aid the user in generating the Command Codes and displaying/monitoring the Status Codes. Consult the application program users instructions for Remote operation procedure.

The application program should issue only one string at a time. After each functional command is issued the status should be checked to ensure that the command has been properly executed. The application program should allow sufficient time for the function to be completed before checking the status.

The application program should facilitate checking the status just prior to issuing a command - since the status could have been changed by a fault condition of the amplifier or by operator activation of the amplifier. Periodic checking of the status is also recommended.

3.9 TWTA GENERAL CONSIDERATIONS

This section is intended to offer some guidelines regarding operation, storage and use of AR TWTAs.

Storage: TWTAs, as with other electronic equipment, are best stored in a benign environment at reasonably constant temperature. Service life is not improved by periodic operation.

Availability: For critical missions, and after long periods of storage, it is recommended that TWTA operation be checked sufficiently in advance of the mission to permit repair if required. Though service life is not improved by periodic operation, users experiencing amplifier trip due to body over current may benefit by periodically operating a unit with high voltage and grid on, but no RF drive. Such operation for about one hour on a weekly basis should effectively reduce nuisance tripping. Since the cathode structure has finite life, extended periods of non-functional operation of TWTAs is not recommended. An alternate approach, if periodic trip off has been observed, is to operate the unit without RF input for 1-2 hours before planned functional operation, resetting the unit after occasional trip off.

Cooling during Operate Mode: AR TWTAs have their air outlets and inlets on the rear panels. It is important to prevent the heated air, which is expelled from the TWTA's air outlets, from being recycled into the air inlets. Applications should have a clearance behind the TWTA of at least two feet for single bench top units and at least three feet for the higher power units, or the heated air should be ducted away.

Operation in Standby Mode: Standby mode for TWTAs readies the unit for operation. In this mode the filaments are on but the high voltage is off. TWTAs should not be left in this Standby mode for extended periods. Where practical, operational procedures should limit the time on Standby mode to less than approximately one hour. (See *Explanation of....*, below)

Operate Turn on: When selecting the Operate mode, when high voltage is first turned on, there may be some internal TWT arcing which can cause protective circuits to deselect the Operate mode, thereby returning the unit to the Standby mode. There may be a report of body over-current fault. In either case, if there is no other contraindication, the Operate mode may be selected again. This procedure maybe repeated,

if needed up to 25 times, until the Operate mode is actually set. If this condition persists, contact AR Service for additional assistance. (See *Explanation of...*, below)

Noise Power Density (NPD): TWTAs produce RF noise over their operating frequency range, as specified by the Noise Power Density (NPD). This noise is significantly higher than the noise produced by typical solid state amplifiers, and is inherent in present TWTAs. The noise may surprise users new to TWTAs when it accumulates and results in a significant indication in a broadband measurement device – such as a power meter or field probe. The error produced by this indication is not significant when operating near rated TWTA power levels, but may cause difficulty when trying to operate high power TWTAs at low output power levels.

For example, consider a hypothetical typical NPD of -76 dBm/Hz, from a 4 GHz bandwidth amplifier. A broadband detector might see the NPD as $[-76 \text{ dBm/Hz} + 10 (\log 4 \times 10^9) \text{ BW factor} = -76 + 96 =] +20$ dBm, or 0.1 watts. This power is insignificant for a user operating at 200 watts (+53 dBm), but may be very noticeable to a user trying to operate below 1 watt (+30 dBm). [One watt is 0.5% of (23dB below) rated power for a 200 watt amplifier.] A field probe user who obtains a 200 V/M field with 200 watts, may see a field as high as $[53\text{dBm} - 20\text{dBm} = 33\text{dB below } 200 \text{ V/M} =] 4.5 \text{ V/M}$ due to this hypothetical NPD.

For these applications the use of a lower power amplifier is highly recommended, especially when considering safety issues. Alternatively, additional power loss in the form of an added high power microwave attenuator, or preferably an increased space loss for radiated fields, may be used to lower the noise received by the broadband measurement device.

Explanation of Limiting the Time in Standby mode and of Repeated Operate Selection.

Traveling wave tubes tend to get “gassy” if they are left in a Standby mode for extended periods of time. In this Standby mode, the heater (filament) is on but there is no high voltage applied to the collector (or high voltage is applied to the collector but the grid is off). This is the normal state after a tube’s warm up time, just prior to entering the Operate mode.

In this state the cathode end of the TWT is heating up but the electron “Beam” is off. In other words, there is no cathode current. As the cathode heats up, gas trapped in the structure of the tube can be released, thus corrupting the vacuum of the tube. If the tube become too “gassy”, arcing may occur when the high voltage is fully applied in the Operate mode. Another possible failure mode is a body over-current fault when the beam is turned on and the tube is “gassy”.

Occasional arcing is normal for a TWT. The support components are designed to handle this, protecting both the TWT and its support circuitry. However, if the tube arcs two or three times in rapid succession, or worse yet repeatedly, a fault will be sensed that will shut the high voltage off, thus removing the unit from Operate status. The remedy usually recommended is to repeat the selection of the Operate mode until the unit remains in Operate. It as been found that most of the faults that can be cleared by this method will be cleared within 25 attempts to enter the Operate mode.

Once the tube is operating normally, gas will continue to evolve at a slow enough rate that the TWTA will not fault. This happens because the gas in the tube will interact with the beam and become ionized. As the electrons in the beam hit the gas molecules they ionize the gas, at which point it is accelerated into the collector structure and buried deep enough so that it ceases to be a problem.

To preclude this gassing problem, and thus reduce the need for repeating the Operate selection, it is recommended that the time in Standby be limited to about one hour. Extended periods in Standby may result in an inability to clear the fault by this method. In this case, service measures may be needed to correct the

unit. Thus, users should reduce the likelihood of occurrence of this problem by limiting the amount of time in the Standby mode.

The service measures involve pulsing of the tube beam current and gradually increasing the duty of the pulsing until the unit will operate continuously. Note that a similar condition can exist for tubes with grids when the TWTA is in the Operate mode (high voltage is on) but gating (control) input is set so that the grid turns off the TWT beam current. Operational procedures should also limit the time in this mode.

4. MAINTENANCE

The TWTA does not require routine scheduled maintenance. The only moving parts are the elements of switches, relays and blowers. Preventive maintenance is recommended in Paragraph 4.3.

The TWTA is basically a factory repairable unit. However, since limited logic schematics and partial parts information is supplied in this manual (Section 5) some user service organizations may choose to perform their own corrective maintenance. **Warnings and Cautions should be observed.**

4.1 SAFETY WARNING



WARNING:

Only technicians thoroughly familiar with the high voltages present in microwave tube amplifiers must perform Service work in general, and with this equipment in particular.

Never handle the TWT leads or the high-voltage connectors unless it has been positively established that the high-voltage filter capacitors have been discharged to a *known* safe level.



CAUTION:

A malfunctioning power supply can cause damage to the TWT. When troubleshooting the TWTA, remove the TWT and substitute suitable loads to prevent damage to the TWT.

4.2 UNAUTHORIZED REPAIRS



CAUTION:

Unauthorized repairs or modification of this product during the warranty period may void the warranty. In the event that the TWTA malfunctions while it is still under warranty, always contact an authorized service representative.

4.3 PREVENTIVE MAINTENANCE

The RF characteristics and power supply voltages and currents of the TWTA should be logged on a regular basis. Maintenance should be performed if significant deviations from the logged values appear. If the unit is under warranty, contact an authorized service representative if impaired performance is suspected.

If there is accumulated dust on the air intake grill, clean it with dry compressed air. If significant dust has been noted on the air intake grill, it may be desirable to vacuum the dust and debris from inside the enclosure.

To open the enclosure:

1. Remove the amplifier from the cabinet or rack as follows:

NOTE: Due to the weight of the unit, the removal of the amplifier from the cabinet or rack is a two person operation.

Disconnect power, RF, and any other interface connectors. On the rear of the unit, remove any screws used to connect brackets to the amplifier. On the front of the unit, remove the four screws holding the front panel onto the cabinet. Carefully slide the amplifier out of the front of the cabinet.

2. Remove the 6 screws that secure the lower cover and the 6 screws that secure the upper cover. Remove the covers to gain access to the interior of the TWTA.

Vacuum dust and debris from inside the enclosure. Clean dust from the TWTA and its flying leads. Remove any dirt from around the three high voltage connectors. While the cover is off, check for loose wires, components or fasteners.

Reassemble in the reverse order.

4.4 TROUBLESHOOTING

Symptom	Possible cause
TWT or power supply over temperature	Air inlet filter(s) dirty Collector heat sink dirty Inadequate clearance behind TWTA High air inlet temperature Defective blower or power supply
No response when main power turned on	Panel open interlock switch open
Control module display does not come up; unit does not beep when powered up	Shorted or defective control module power supply Control module failure
Control module does not boot	EPROM(s) missing.
Control module datalink failure or Communication Problem error appears	HPA interface failure. Fiber optic link failure ± 15 VDC supply failure
Heater power supply does not come up	Defective low voltage power supply module Defective heater power supply module
No high voltage	Open external interlock Keylock switch on INHIBIT or REMOTE Defective high voltage power supply.
Voltages normal, but no RF output, helix current low	No RF input Defective remote control board Defective SSA Gain turned down

After review of the symptoms of the failure, the user may want to check for a loose connector or component especially after rough handling of the unit. Look externally for physical damage and internally for unmated or loose parts.

The service technician should become familiar with the internal mechanical construction to permit correct re-assembly. Limited troubleshooting may be conducted, with caution, based on the failure symptom and an understanding of the logic/schematic diagrams.

4.5 NON-REPAIRABLE MODULES

The High Voltage Diode/Cap Assembly, the High Voltage Filter Assemblies, and the Heater Supply are encapsulated modules and are not repairable. Contact an authorized service representative if replacement modules are needed.

5. TECHNICAL DOCUMENTATION

NOTE: The purpose of this technical documentation section is to provide a guide to the TWTA for technician-level servicing. It is intended for use by qualified technical personnel who must troubleshoot and repair the TWTA in the field. Such repairs are typically limited to replacement of modules or major components. For this reason, documentation pertaining to the highest levels of the system and to system control logic is included.

5.1 TOP LEVEL BUILD TREE

5.1.1 A33961-000, 200 Watt K Band HPA

REF. DESIG.	ETM P/N	DESCRIPTION
1	A33961-000	HPA 200 WATT K-BAND W/ 2 L3 TUBES (AR)
1A1	A34032-000	RF DRAWER 200 WATT K-BAND
1A1	A34208-000	CABINET KIT, 200K RF DRAWER
1A1A1	A28051-341	MICROWAVE POWER ASSEMBLY 200 WATT K-BAND
1A1A2-A3	A23692-000	INSULATED FAN DRIVER
1A1A2-A3T1	A09594-000	FAN DRIVER TRANSFORMER
1A1A12	A32363-000	VSWR/FOLDBACK BOARD ASSEMBLY
1A1A12	A32363-900	ALTERA FIRMWARE FOR VSWR/FOLDBACK BOARD
1A2	A34036-000	POWER SUPPLY DRAWER 200 WATT K-BAND
1A2	A26856-012	FRONT PANEL ASSY, AR 200K/KA SINGLE PHASE
1A2A1	A22700-900	HPA DISPLAY BOARD
1A2	A34209-000	CABINET KIT, 200K/KA PS DRAWER
1A2A1, A8	A22826-930	HV POWER SUPPLY FOR L-3 TWT 8928H (PULSED 2-TUBE UNIT)
1A2A1, A8A1	A23709-000	HEAT SINK/MOTHER BOARD ASSY
1A2A1, A8A2	A23687-001	LVPS, 85-265VAC IN, 15V/4A, 5V/1.5A-15V/0.5A OUT
1A2A1, A8A3	A16485-893	HPA LOGIC AND CONTROL MODULE FOR 130K, 130KA (10US VSWR), FIXED VSWR REF.
1A2A1, A8A4	A23683-100	POWER FACTOR MODULE (500W)
1A2A1, A8A4L4	A09006-000	PFC INDUCTOR FOR 100VAC-255VAC
1A2A1, A8A5	A23710-000	POWER ASSEMBLY FOR 100WKU
1A2A1, A8A5L1, L1A	A09007-000	INDUCTOR FOR BUCK REGULATOR
1A2A1, A8A5T1 (E42)	A09402-000	XFMR,GATE DRIVE (HAND WOUND)
1A2A1, A8A5T2 (E41)	A09403-000	XFMR,GATE DRIVE (HAND WOUND)
1A2A1, A8A6	A23707-928	HV DIODE/CAP ASSY FOR K-BAND TWT L-3 8928H
1A2A1, A8A6T1	A09571-928	HV XFMR FOR L-3 TWT 8928H
1A2A1, A8A7	A21461-892	HIGH VOLTAGE FILTER MODULE FOR 130K & 130KA
1A2A1, A8A8	A23684-893	FOCUS ELECTRODE FOR L-3 8928H (FIXED -950V, 0V, 2-TUBE-PULSED)
1A2A1, A8A8A1	A23693-892	FE HV BD (FIXED -950V, 0V)
1A2A1, A8A8A1T3	A09595-064	-950V BIAS SUPPLY XFMR
1A2A1, A8A8A1T4-T5	A09599-000	XFMR GATE DRIVE TRANSFORMER
1A2A1, A8A8A2	A23715-124	PIJ/PSC MODULATOR CONTROL BOARD FOR 2-TUBE PULSED / CW APPLICATION. (HPAS W/ KEYLOCK)
1A2A1, A8A9	A25963-001	HEATER MODULE,MM WAVE, NO HV LEAD
1A2A1, A8A9D30	A32660-000	DIODE BLOCK
1A2A1, A8A9T1	A09409-000	XFMR,HEATER FEEDBACK
1A2A1, A8A9T2	A09408-000	XFMR,HEATER POWER
1A2A1, A8A10	A10017-892	PWM BD FOR 130K & 130KA, -14KV REG, PULSE + CW
1A2A1, A8A11	A25398-928	FACTORY SELECT PARTS, 8928H-1 TWT
1A2A1, A8A12	A10007-000	ANODE MODULE ASSY
1A2A1, A8A12A1	A10008-000	ANODE HV ASSY
1A2A1, A8A12A1T1	A09407-000	PULSE TOP XFMR,FOR L BAND
1A2A1, A8A12A1T2	A09228-000	FEEDBACK XFMR,HAND WOUND
1A2A1, A8A12A2	A10009-000	MODULATOR CONTROL
1A2A1, A8A13	A34333-000	CATHODE REFERENCE MODULE FOR 8928H-1 & 8929H-1 TWTs
1A2A2	A24830-011	EMERGENCY BYPASS BOARD, LOW LEVEL FOLDBACK TRIP (<1V)
1A2A3	A27509-301	HPA CONTROL CHASSIS ASSY, GPIB/LINK TRANSCEIVER BOARD, 200UM HCS FIBERS
1A2A3A1	A31609-000	E00255-000 POWER SUPPLY ASSEMBLY
1A2A3A2	A25450-000	CPU BOARD W/POWERFAIL (20MHZ)
1A2A3A3	A22488-013	GPIB/LINK TRANSCEIVER BOARD, 5U AND 6U TWT PRODUCTS, 200UM HCS FIBERS
1A2A4, A10	A25444-001	HPA INTERFACE BOARD (200UM GLASS FIBERS)
1A2A4, A10U15	A31346-000	DAC REPLACEMENT BOARD FOR U00725. DUAL CHANNEL
1A2A8	A28052-002	WIRING KIT, 200W KA BAND (GLASS FIBERS)
1A2A11	A29184-000	7 CHANNEL DATA STEERING BOARD, 9-18 VDC, (W/SOCKETS, ALL VERT OPTICS)

5.1.2 A33962-000, 200 Watt KA Band HPA

REF. DESIG.	ETM P/N	DESCRIPTION
1	A33962-000	200 WATT KA-BAND HPA W/ 2 L3 TUBES (AR)
1A1	A34033-000	RF DRAWER 200 WATT KA-BAND
1A1	A34210-000	CABINET KIT, 200KA RF DRAWER
1A1	A34210-001	CABINET KIT, 200KA RF DRAWER
1A1A1	A28051-351	MICROWAVE POWER ASSEMBLY 200KA
1A1A2-A3	A23692-000	INSULATED FAN DRIVER
1A1A2-A3T1	A09594-000	FAN DRIVER TRANSFORMER
1A1A12	A32363-000	VSWR/FOLDBACK BOARD ASSEMBLY
1A1A12	A32363-900	ALTERA FIRMWARE FOR VSWR/FOLDBACK BOARD
1A1	A34033-001	RF DRAWER 200 WATT KA-BAND
1A2	A34035-000	POWER SUPPLY DRAWER 200 WATT KA-BAND
1A2	A26856-012	FRONT PANEL ASSY, AR 200K/KA SINGLE PHASE
1A2A1	A22700-900	HPA DISPLAY BOARD
1A2	A34209-000	CABINET KIT, 200K/KA PS DRAWER
1A2A1, A8	A22826-931	HV POWER SUPPLY FOR L-3 TWT 8929H
1A2A1, A8A1	A23709-000	HEAT SINK/MOTHER BOARD ASSY
1A2A1, A8A2	A23687-001	LVPS, 85-265VAC IN, 15V/4A, 5V/1.5A-15V/0.5A OUT HPA LOGIC AND CONTROL MODULE FOR 130K, 130KA (10US VSWR), FIXED VSWR REF.
1A2A1, A8A3	A16485-893	
1A2A1, A8A4	A23683-100	POWER FACTOR MODULE (500W)
1A2A1, A8A4L4	A09006-000	PFC INDUCTOR FOR 100VAC-255VAC
1A2A1, A8A5	A23710-000	POWER ASSEMBLY FOR 100WKU
1A2A1, A8A5L1, L1A	A09007-000	INDUCTOR FOR BUCK REGULATOR
1A2A1, A8A5T1 (E42)	A09402-000	XFMR,GATE DRIVE (HAND WOUND)
1A2A1, A8A5T2 (E41)	A09403-000	XFMR,GATE DRIVE (HAND WOUND)
1A2A1, A8A6	A23707-929	HV DIODE/CAP ASSY FOR KA-BAND TWT L-3 8929H
1A2A1, A8A6T1	A09571-929	HV XFMR FOR L-3 TWT 8929H
1A2A1, A8A7	A21461-892	HIGH VOLTAGE FILTER MODULE FOR 130K & 130KA
1A2A1, A8A8	A23684-893	FOCUS ELECTRODE FOR L-3 8928H (FIXED -950V, OV, 2-TUBE-PULSED)
1A2A1, A8A8A1	A23693-892	FE HV BD (FIXED -950V, 0V)
1A2A1, A8A8A1T3	A09595-064	-950V BIAS SUPPLY XFMR
1A2A1, A8A8A1T4-T5	A09599-000	XFMR GATE DRIVE TRANSFORMER
1A2A1, A8A8A2	A23715-124	PIJ/PSC MODULATOR CONTROL BOARD FOR 2-TUBE PULSED / CW APPLICATION. (HPAS W/ KEYLOCK)
1A2A1, A8A9	A25963-001	HEATER MODULE,MM WAVE, NO HV LEAD
1A2A1, A8A9D30	A32660-000	DIODE BLOCK
1A2A1, A8A9T1	A09409-000	XFMR,HEATER FEEDBACK
1A2A1, A8A9T2	A09408-000	XFMR,HEATER POWER
1A2A1, A8A10	A10017-892	PWM BD FOR 130K & 130KA, -14KV REG, PULSE + CW
1A2A1, A8A11	A25398-929	FACTORY SELECT PARTS, 8929H-1 TWT
1A2A1, A8A12	A10007-000	ANODE MODULE ASSY
1A2A1, A8A12A1	A10008-000	ANODE HV ASSY
1A2A1, A8A12A1T1	A09407-000	PULSE TOP XFMR, FOR L BAND
1A2A1, A8A12A1T2	A09228-000	FEEDBACK XFMR,HAND WOUND
1A2A1, A8A12A2	A10009-000	MODULATOR CONTROL
1A2A1, A8A13	A34333-000	CATHODE REFERENCE MODULE FOR 8928H-1 & 8929H-1 TWTS
1A2A2	A24830-011	EMERGENCY BYPASS BOARD, LOW LEVEL FOLDBACK TRIP (<1V) HPA CONTROL CHASSIS ASSY, GPIB/LINK TRANSCEIVER BOARD, 200UM HCS FIBERS
1A2A3	A27509-301	
1A2A3A1	A31609-000	E00255-000 POWER SUPPLY ASSEMBLY
1A2A3A2	A25450-000	CPU BOARD W/POWERFAIL (20MHZ) GPIB/LINK TRANSCEIVER BOARD, 5U AND 6U TWT PRODUCTS, 200UM HCS FIBERS
1A2A3A3	A22488-013	
1A2A4, A10	A25444-001	HPA INTERFACE BOARD (200UM GLASS FIBERS)
1A2A4, A10U15	A31346-000	DAC REPLACEMENT BOARD FOR U00725. DUAL CHANNEL
1A2A9	A28052-002	WIRING KIT, 200W KA BAND (GLASS FIBERS) 7 CHANNEL DATA STEERING BOARD, 9-18 VDC, (W/SOCKETS, ALL VERT OPTICS)
1A2A11	A29184-000	

5.2 SCHEMATICS

10-16485-893	HPA Logic and Control (A16485-893 for 18G26 & 26G40)
10-25444-001	HPA Interface (A25444-001)
10-32363-000	VSWR & FOLDBACK board assembly (A32363-000)
10-24830-011	Emergency bypass board, low level fold back (A24830-011)
10-33961-000	HPA 200T K & Ka Band (18G26 & 26G40)

5.3 PARTS LISTS

A16485-893	26G40 HPA Logic and Control Module
A22826-930	18G26 Power Supply
A22826-931	26G40 Power Supply
A24830-011	Emergency Bypass Foldback board
A25444-001	HPA Interface Board (200UM Glass)
A28051-341	18G26 Microwave Assembly
A28051-351	26G40 Microwave Assembly
A28052-002	Wring Kit 200 K & Ka
A32363-000	VSWR & fold back board assembly
A33961-000	200T18G26z5A TWTA (AR)
A33962-000	200T26z5G40A TWTA (AR)

5.3.1 Parts List, 200T 18G26z5A & 26z5G40A, HPA Logic and Control Module for 130K, 130KA, A16485-893

REF. DESIG.	ETM P/N	DESCRIPTION	QUANTITY
	A16485-893	HPA LOGIC AND CONTROL MODULE FOR 130K, 130KA (10US VSWR), FIXED VSWR REF.	
	B16485-000	HPA LOGIC AND CONTROL BOARD	1
C11	C16333-000	CAP,33UF,25V,AERL,5MM DIAM (NICHICON, UVR1E330MDD)	1
C2, C5, C15, C58	C31028-000	CAP,1000PF,200VDC,10%,CER,1% FAILURE,(KEMET CKR05 SERIES W/"V" OPTION)	4
C3, C9, C10, C13, C14, C17, C19, C21, C22, C27, C28, C30, C31, C33, C36, C41, C46	C31032-000	CAP,0.01MF,200VDC,10%,CER,1% FAILURE,(KEMET CKR06 SERIES W/"V" OPTION)	17
C61	C31033-000	CAP,0.022MF,100VDC,10%,CER,1% FAILURE,(KEMET, CKR06BX223K W/V OPTION)	1
C24, C34, C40, C60	C31036-000	CAP,0.1MF,100VDC,10%,CER, (KEMET, M39014/2-1310V)	4
C1, C4, C6, C7, C16, C18, C25, C26, C32, C37-C39, C43-C45, C48, C49	C31040-000	CAP,1MF,50VDC,10%,CER,1% FAILURE,(KEMET CKR06 SERIES W/"V" OPTION)	17
D16, D23, D31	D10965-000	ZENER,15V,(FAIRCHILD SEMICONDUCTOR, 1N965B)	3
D1, D3-D5, D7-D13, D17-D19, D21, D22, D25, D26, D28, D30, D35, D37, D38, D40	D14454-000	DIODE,AXIAL,(FAIRCHILD SEMICONDUCTOR, 1N4454)	24
D36	D14733-000	ZENER,5.1V,1W,10%,AXIAL,(FAIRCHILD SEMICONDUCTOR, 1N4733A)	1
	F00010-000	WASHER,#2,LOCK,SST	3
	F00101-000	WASHER,#4 NAS,(PRO-STAINLESS NAS620C4)	4
	F00107-000	#4 SPLIT LOCK WASHER,SST	2
	F10086-000	PHP,2-56 X 3/16SST	3
	F31004-000	NUT,4-40,HX,SMALL PATTERN,MIL-SPEC	2
	G00043-000	HEX STANDOFF ,4-40 THREAD SS,FOR D SUBMIN CONN (PRO STAINLESS, 620013)	2
J2	J10370-000	CONN,37 PIN,MALE,D-SUB,PCB RIGHT ANGLE, (AMP, 5747252-4)	1
J4, J5	J18086-000	CONN.,SMA,JACK RECEPTACLE,RIGHT ANGLE,0-18GHZ,PC MOUNT [JOHNSON COMPONENTS 142-0701-301]	2
J1	N25003-000	HYPERTRONICS CONN,29 PIN MALE RIGHT ANGLE,(CUT ENDS)	1
Q2	Q22907-000	TRANSISTOR,PNP, (ST, 2N2907A) TO-18	1
R1, R9, R19, R37, R44, R50	R00100-000	RES,10 OHM,1/4W,5%,CC,(OHMITE, OD100JE)	6
R4, R20, R27, R29	R01100-000	RES,100 OHM,1/4W,5%,CC,(OHMITE, OD101JE)	4
R5, R17, R18, R28, R34, R45, R49, R53, R54, R59, R71, R88	R02100-000	RES,1K,1/4W,5%,CC,(OHMITE, OD102JE)	12
R12	R02150-000	RES,1.5K,1/4W,5%,CC,(A/B RC07GF152J)	1
R6	R02270-000	RES,2.7K,1/4W,5%,CC,(OHMITE, OD272JE)	1
R30, R31, R36	R02470-000	RES,4.7K,1/4W,5%,CC,(OHMITE, OD472JE)	3
R86, R87	R02510-000	RES,5.1K,1/4W,5%,CC,(OHMITE, OD512JE)	2
R75	R02560-000	RES,5.6K,1/4W,5%,CC,(OHMITE, OD562JE)	1
R38, R77, R90	R03100-000	RES,10K,1/4W,5%,CC,(OHMITE, OD103JE)	3
R32	R03470-000	RES,47K,1/4W,5%,CC,(A/B RC07GF473J)	1
R35	R05820-000	RES,8.2M,1/4W,5%,CC,(OHMITE, OD825JE)	1

REF. DESIG.	ETM P/N	DESCRIPTION	QUANTITY
R13, R14	R10002-000	TRIMPOT,5K,1/2W,10%,CERMET,20T,SIDE ADJ,(BOURNS 3296X-1-502)	2
R76	R21499-000	RES,4.99K, 1%,MF,100PPM,(DALE RN55D4991F)	1
R10	R21523-000	RES,5.23K, 1%,MF,100PPM,(DALE RN55D)	1
R16	R21866-000	RES,8.66K, 1%,MF,100PPM,(DALE RN55D)	1
R52, R73	R21887-000	RES,8.87K, 1%,MF,100PPM,(DALE RN55D)	2
R67	R21953-000	RES,9.53K, 1%,MF,100PPM,(DALE RN55D9531F)	1
R21, R47, R48	R22200-000	RES,20K, 1%,MF,100PPM,(DALE RN55D2002F)	3
R79, R80	R22470-000	RES,47K, 1%,MF,100PPM,(DALE RN55D4702F)	2
R42, R60, R61, R89	R23100-000	RES,100K, 1%,MF,100PPM,(DALE RN55D1003F)	4
R33, R55	R23698-000	RES,698K, 1%,MF,100PPM,(DALE RN55D6983FB14)	2
R41	R23750-000	RES,750K, 1%,MF,100PPM,(DALE RN55D)	1
R66	R23953-000	RES,953K, 1%,MF,100PPM,(DALE RN55D9533F)	1
R15	R32020-000	TRIMPOT,10K,1/2W,10%,CERMET,20T,SIDE ADJ,(BI TECHNOLOGIES, 67XR10KLF)	1
U4-U6	U02390-000	IC,QUAD COMPARATOR,(NAT LM139J)	3
U7	U03240-000	IC,LOW POWER OP AMP,(NAT LM324)	1
U9	U10070-000	REFERENCE,PRECISION 10V [LINEAR TECH LT1031DCH]	1
U8	U17805-000	IC,5V REGULATOR,TO-220,(NAT LM340T-5.0)	1
U1-U3	U20148-000	IC,HEX INVERTER,SCHMIDTT TRIGGER,(74HC14 (SSD)	3
RP8	U30106-000	IC,10K,RES NETWORK,6 PIN,SIP (DALE MSP06A- 01-103G)	1
RP1-2, RP5-7, RP9	U30410-000	IC,10K,2%,0.40A,10 PIN,ISOLATED RESISTORS (DALE MSP10C-03-103G OR BOURNS 4610H-102- 103)	6
RP4	U31020-000	IC,1K RES NETWORK,SIP,(BI TECHNOLOGIES, L061C102LF)	1
W3-W8	W12200-000	WIRE, 22 AWG, BLU, 600V, TEFLON, (BELDEN 83006)	6
	A16485-893	HPA LOGIC AND CONTROL MODULE FOR 130K, 130KA (10US VSWR), FIXED VSWR REF.	

5.3.2 Parts List, 200T18G26z5A, HV Power Supply For L-3 TWT 8928H (Pulsed 2-Tube Unit), A22826-930

REF. DESIG.	ETM P/N	DESCRIPTION	QUANTITY
A12	A10007-000	ANODE MODULE ASSY	1
A10	A10017-892	PWM BD FOR 130K & 130KA, -14KV REG, PULSE + CW	1
A3	A16485-893	HPA LOGIC AND CONTROL MODULE FOR 130K, 130KA (10US VSWR), FIXED VSWR REF.	1
A7	A21461-892	HIGH VOLTAGE FILTER MODULE FOR 130K & 130KA	1
A4	A23683-100	POWER FACTOR MODULE (500W)	1
A8	A23684-893	FOCUS ELECTRODE FOR L-3 8928H (FIXED -950V, OV, 2-TUBE-PULSED)	1
A2	A23687-001	LVPS, 85-265VAC IN, 15V/4A, 5V/1.5A-15V/0.5A OUT	1
A6	A23707-928	HV DIODE/CAP ASSY FOR K-BAND TWT L-3 8928H	1
A1	A23709-000	HEAT SINK/MOTHER BOARD ASSY	1
A5	A23710-000	POWER ASSEMBLY FOR 100WKU	1
A11	A25398-928	FACTORY SELECT PARTS, 8928H-1 TWT	1
A9	A25963-001	HEATER MODULE,MM WAVE, NO HV LEAD	1
A13	A34333-000	CATHODE REFERENCE MODULE FOR 8928H-1 & 8929H-1 TWTS	1

5.3.3 Parts List, 200T26z5G40A, HV Power Supply For L-3 TWT 8929H, A22826-931

REF. DESIG.	ETM P/N	DESCRIPTION	QUANTITY
A12	A10007-000	ANODE MODULE ASSY	1
A10	A10017-892	PWM BD FOR 130K & 130KA, -14KV REG, PULSE + CW	1
A3	A16485-893	HPA LOGIC AND CONTROL MODULE FOR 130K, 130KA (10US VSWR), FIXED VSWR REF.	1
A7	A21461-892	HIGH VOLTAGE FILTER MODULE FOR 130K & 130KA	1
A4	A23683-100	POWER FACTOR MODULE (500W)	1
A8	A23684-893	FOCUS ELECTRODE FOR L-3 8928H (FIXED -950V, OV, 2-TUBE-PULSED)	1
A2	A23687-001	LVPS, 85-265VAC IN, 15V/4A, 5V/1.5A-15V/0.5A OUT	1
A6	A23707-929	HV DIODE/CAP ASSY FOR KA-BAND TWT L-3 8929H	1
A1	A23709-000	HEAT SINK/MOTHER BOARD ASSY	1
A5	A23710-000	POWER ASSEMBLY FOR 100WKU	1
A11	A25398-929	FACTORY SELECT PARTS, 8929H-1 TWT	1
A9	A25963-001	HEATER MODULE,MM WAVE, NO HV LEAD	1
A13	A34333-000	CATHODE REFERENCE MODULE FOR 8928H-1 & 8929H-1 TWTS	1

5.3.3 Emergency Bypass Board, Low Level Foldback Trip (<1V); A24830-011

REF. DESIG.	ETM P/N	DESCRIPTION	QUANTITY
	B24830-000	EMERGENCY BYPASS BOARD	1
C3-C5	C04105-000	CAP, 0.1MF, +/-20%, 100V, MON [KEMET C331C104M1R5CA]	3
C6	C30010-000	CAP, 10MF, 35V, TANT, RADIAL, (NEMCO TB10-35K1)	1
C1, C2	C31032-000	CAP, 0.01MF, 200VDC, 10%, CER, 1% FAILURE, (KEMET CKR06 SERIES W/"V" OPTION)	2
C7	C31040-000	CAP, 1MF, 50VDC, 10%, CER, 1% FAILURE, (KEMET CKR06 SERIES W/"V" OPTION)	1
D1, D2	D14454-000	DIODE, AXIAL, (FAIRCHILD SEMICONDUCTOR, 1N4454)	2
D3, D4	D14733-000	ZENER, 5.1V, 1W, 10%, AXIAL, (FAIRCHILD SEMICONDUCTOR, 1N4733A)	2
I4	I10096-000	LED, GREEN, DIFFUSED, T1-3/4 (LUMEX, SSL-LX5093GD)	1
TP2	J16212-000	TEST JACK, RED, VERTICAL, (EF JOHNSON 105-0852-001)	1
TP3	J16213-000	TEST JACK, ORANGE, VERTICAL, (EF JOHNSON 105-0856-001)	1
J2	J18086-000	CONN, SMA, JACK RECEPTACLE, RIGHT ANGLE, 0-18GHZ, PC MOUNT [JOHNSON COMPONENTS 142-0701-301]	1
J1	J31055-000	CONN, D-SUB, 15 PIN, FEMALE, STRAIGHT, PCB MOUNT, [AMPHENOL, L77DA15SU]	1
Q4, Q5	Q22907-000	TRANSISTOR, PNP, (ST, 2N2907A) TO-18	2
R18, R23	R01100-000	RES, 100 OHM, 1/4W, 5%, CC, (OHMITE, OD101JE)	2
R21	R01514-000	RES, 510 OHM, 1/2W, 5%, CC, (A/B, RC20GF511J)	1
R19	R02100-000	RES, 1K, 1/4W, 5%, CC, (OHMITE, OD102JE)	1
R22	R02270-000	RES, 2.7K, 1/4W, 5%, CC, (OHMITE, OD272JE)	1
R16, R17	R02470-000	RES, 4.7K, 1/4W, 5%, CC, (OHMITE, OD472JE)	2
R9, R13, R15	R03100-000	RES, 10K, 1/4W, 5%, CC, (OHMITE, OD103JE)	3
R20	R20267-000	RES, 267 OHM, 1%, MF, 100PPM, (DALE, RN55D)	1
R10-R12	R23100-000	RES, 100K, 1%, MF, 100PPM, (DALE RN55D1003F)	3
R2	R30070-000	TRIMPOT, 5K, 1/2W, 10%, CERMET, 100PPM, 20T, TOP ADJ, (BI TEHCNOLOGIES 67WR5KLF)	1
U2	U11458-000	IC, DUAL OP AMP, (NAT LM1458/NOPB)	1
U1	U17808-000	IC, 8V REGULATOR, TO-220, (NAT LM340T-8.0 OR LM7808CT)	1

5.3.4 Parts List, HPA Interface Board (200UM Glass Fibers), A25444-001

REF. DESIG.	ETM P/N	DESCRIPTION	QUANTITY
U15	A31346-000	DAC REPLACEMENT BOARD FOR U00725. DUAL CHANNEL	1
	B25444-000	HPA INTERFACE BOARD	1
C161	C03105-000	CAP, 0.01MF, +/-10%, 100V, CER, RADIAL [AVX SR201C103KAA]	1
C171	C04223-000	CAP, 0.22MF, +/-10%, 35V, TANT, RADIAL [JAMECO 33507]	1
		CAP, 1.5MF, 35V, TANT, RADIAL [AVAX, TAP155K035SCS]	
C20, C32, C100	C05153-000		4
C129, C163	C05223-000	CAP ,2.2MF, +/-10%, 35V, SOLID SEALED TANT, RADIAL [SPRAGUE 199D225X9035BA1]	2
C80, C81, C164	C06103-000	CAP, 10MF, +/-20%, 25V, SOLID TANT, RADIAL [KEMET T356E106K025AS]	3
C15	C06220-000	CAP, 22MF, +/-10%, 16V, SOLID TANT, RADIAL [AVX TAP226K016SCS]	1
C99	C16103-000	CAP, 10MF, 35V, AERL, (NICHICON UVR1V100MDA)	1
C101	C17472-000	CAP, 470UF +/-20%, 16V, AERL, (NICHICON, UVR1C471MPD)	1
C47, C67	C17474-000	CAP, 470UF, 50V, AERL, [PANASONIC P5279]	2
C44	C30066-000	CAP 47 MF, 35V, SOLID TANT. RADIAL, (KEMET T356M476K035AS)	3
C6, C7, C9, C13, C16, C39, C43, C69, C165, C166	C31016-000	CAP, 100PF, 200VDC, 10%, CER, 1% FAILURE, (KEMET CKR05 SERIES W/"V" OPTION)	10
C1-C5, C10, C11, C22-C26, C28, C30, C33, C35, C40-C42, C48-C51, C53, C62-C65, C70, C71, C73, C77, C79, C83, C85, C87-C89, C91, C94, C96-C98, C102, C103, C105, C107-C117, C121, C125, C132, C167	C31036-000	CAP, 0.1MF, 100VDC, 10%, CER, (KEMET, M39014/2-1310V)	61
C12, C14, C17-C19, C21, C27, C29, C31, C34, C36, C38, C45, C46, C52, C54-C61, C66, C68, C72, C75, C82, C84, C86, C90, C92, C93, C95, C104, C106, C118-C120, C122-C124, C133, C168, C169	C31040-000	CAP, 1MF, 50VDC, 10%, CER, 1% FAILURE, (KEMET CKR06 SERIES W/"V" OPTION)	45
D8, D10, D12, D14-D16, D18, D19	D14007-000	DIODE, 1000V, 1A, AXIAL, (DIODES, INC. 1N4007)	8
D1-D7	D14454-000	DIODE, AXIAL, (FAIRCHILD SEMICONDUCTOR, 1N4454)	7
D9, D17	D14733-000	ZENER, 5.1V, 1W, 10%, AXIAL, (FAIRCHILD SEMICONDUCTOR, 1N4733A)	2
I1	I10074-000	LED, GREEN, ALGAAS, NON-DIFFUSED, (HLMP1540)	1
J5	J10021-000	HEADER, 2 PIN, MALE, RIGHT ANGLE, SERIES 7478 (MOLEX 22-05-3021)	1
J1	J10371-000	D-SUB, 37 PIN MALE, PCB MOUNT, STRAIGHT (POSITRONICS MD37M3S000)	1
XU17	J14161-000	SKT, DIP, 16 PIN, MACH SLEEVES, (AUGAT 516-AG11D)	1
XU26	J14202-000	SKT, DIP, 20 PIN, MACH SLEEVES, (SAMTEC ICA-320-SGT)	1
XU15	J14281-000	SKT, DIP, 28 PIN, MACH SLEEVES, (SAMTEC ICA-628-SGT)	1
TP0	J16210-000	TEST JACK, BLACK, VERTICAL, (EF JOHNSON 105-0853-001)	1
TP1	J16211-000	TEST JACK, BROWN, VERTICAL, (EF JOHNSON 105-0858-001)	1
TP2	J16212-000	TEST JACK, RED, VERTICAL, (EF JOHNSON 105-0852-001)	1

REF. DESIG.	ETM P/N	DESCRIPTION	QUANTITY
TP3	J16213-000	TEST JACK,ORANGE,VERTICAL,(EF JOHNSON 105-0856-001)	1
TP4	J16214-000	TEST JACK,YELLOW,VERTICAL,(EF JOHNSON 105-0857-001)	1
TP5	J16215-000	TEST JACK,GREEN,VERTICAL,(EF JOHNSON 105-0854-001)	1
J4	J18167-000	D-SUB,37 PIN,FEMALE,PCB MOUNT,RIGHT ANGLE (AMP 745784-4)	1
J3	J18180-000	CONN,D-SUB,15 PIN,MALE,STRAIGHT,PCB MOUNT (POSITRONIC MD15M3000)	1
J2	J31013-000	CONN,D-SUB,25 PIN,MALE,RIGHT ANGLE,PCB MOUNT,[AMP 747238-4]	1
XJ1-XJ4	J31014-000	SPRING LATCH KIT,D-SUB,(AMPHENOL 17-529)	4
K1-K6	K02009-000	RELAY,DPDT,5VDC,125V @ 0.5A / 30VDC @ 1A CONTACTS,PCB TERMINALS,SEALED (PANASONIC, TQ2-5V)	6
L1-L4	L00200-000	WIDE BAND CHOKE,(VK200 10/3B FERROXCUBE)	4
Q1-Q8	Q22222-000	TRANSISTOR,NPN, (ST, 2N2222A) TO-18	8
R41	R00680-000	RES,68 OHM,1/4W,5%,CC,(A/B RC07GF680J)	1
R2	R01220-000	RES,220 OHM,1/4W,5%,CC,(OHMITE, OD221JE)	1
R1	R04200-000	RES,200K,1/4W,5%,CC,(A/B RC07GF204J)	1
R6, R8, R58	R20100-000	RES,100 OHM, 1%,MF,50PPM,(DALE RN55C1000F)	3
R57	R20200-000	RES,200 OHM, 1%,MF,100PPM,(DALE RN55D)	1
R59	R22332-000	RES,33.2K, 1%,MF,100PPM,(DALE RN55D)	1
R4, R7	R23100-000	RES,100K, 1%,MF,100PPM,(DALE RN55D1003F)	2
R3, R5	R30071-000	TRIMPOT,10K,1/2W,10%,CERMET,100PPM,20T, TOP ADJ,(BI TECHNOLOGIES, 67WR10KLF)	2
R9, R12, R15, R22, R35, R40, R44	R30103-000	RES,10K,1/8W,1%,MF,AXIAL,50PPM,(DALE RN50C1002F)	7
R17-R21, R23, R25, R28, R31, R42, R43, R46	R30140-000	RES,1K,1/8W,1%,MF,50PPM,(DALE RN50C1001F)	12
R13, R14, R24, R26, R27, R29, R32, R37-R39, R47, R100	R31164-000	RES,100K,1/20W,1%,FILM,AXIAL,50PPM,MIL,(DALE RN50C1003F)	12
U7, U8	U00027-000	IC,ULTRA LOW NOISE PRECISION OP AMP,(ANALOG DEVICES OP27GP)	2
U26	U00029-000	CONVERTER,NO OIL,16BIT,A TO D,SERIAL OUT,[BURR-BROWN ADS7809PB,PB],[ANALOG DEVICES AD977CNZ]	1
U17	U00524-000	IC,INSTRUMENTATION AMP,(ANALOG DEVICES, AD524ADZ) (SSD)	1
U9, U10, U18	U04090-000	IC,4CH ANALOG MULTIPLEXER,(DATEL MXD-409)	3
DP2, DP4, DP5, DP8, DP9	U08010-000	IC,8 COMMON CATHODE CLAMPING DIODES,9 PIN SIP,(ROHM DAN801)	5
DP1, DP3, DP6, DP7, DP10	U08011-000	IC,8 COMMON ANODE CLAMPING DIODES,9PIN SIP,(ROHM DAP801)	5
U27	U11165-000	IC,6.5536MHZ CLOCK OSCILLATOR,1/2 SIZE,(ECLIPTEK EC1100HS-6.5536MHZ) (SSD)	1
U40	U11528-000	IC,VERSALINK TRANSMITTER,HORIZONTAL,(200UM FIBER) (HFBR-1528Z)	1
U54	U12521-000	IC,FIBER OPTIC RECEIVER,HORIZONTAL,(HFBR-2521Z) (SSD)	1
U36	U17545-000	DRIVER, DUAL AND GATE [TI, SN75451BP)	1
U6, U19, U34, U39, U60	U20148-000	IC,HEX INVERTER,SCHMIDTT TRIGGER,(74HC14) (SSD)	5
U42	U20738-000	IC,DUAL J-K FLIP-FLOP W/RESET, (NXD SEMI-CONDUCTORS, 74HC73N)	1
U51	U21328-000	IC,QUAD 2 INPUT NAND,SCHMIDTT TRIGGER,(74HC132) (SSD)	1
U52	U21388-000	IC,3 TO 8 DECODER/DEMUTIPLEXER,INVERTING,(74HC138) (SSD)	1
U32	U21536-000	IC, DUAL 4 INPUT DIGITAL MULTIPLEXER, 16-PIN DIP [TI SN74F153NE4]	1
U35	U22598-000	IC,8 BIT ADDRESSABLE LATCH W/RESET,(74HC259) (SSD)	1
U47	U23909-000	IC,DUAL 4 BIT BINARY/BIQUINARY COUNTER (74HCT390) (SSD)	1
U41, U48	U24018-000	IC,JOHNSON DECADE COUNTER W/10 DECODED	2

REF. DESIG.	ETM P/N	DESCRIPTION	QUANTITY
		OUTPUTS,(74HC4017) (SSD)	
U45	U24138-000	IC,8 BIT BINARY DOWN COUNTER,(74HC40103) (SSD)	1
U43	U26889-000	IC,8 BIT MAGNITUDE COMPARATOR,(74HCT688) (SSD)	1
U22, U24, U57	U28008-000	IC,QUAD 2 INPUT AND,(74HC08) (SSD)	3
U4, U49, U58	U28032-000	IC,QUAD 2 INPUT OR,(74HC32) (SSD)	3
U44, U46	U28040-000	IC,12 BIT DECADE COUNTER,(74HCT4040) (SSD)	2
U5, U13, U14, U23, U25, U33, U50	U28074-000	IC,DUAL D FLIP FLOP W/RESET,(NXP, 74HC74N)	7
U2	U28123-000	IC,DUAL RETRIGGERABLE 1-SHOT,(CD74HC123E) (SSD)	1
U31, U53	U28164-000	IC,8 BIT SERIAL IN PARALLEL OUT SHIFT REGISTER, [STMICROELECTRONICS, M74HC164B1R]	2
U3, U12, U28, U37, U38	U28165-000	IC,8 BIT PARALLEL IN SERIAL OUT SHIFT REGISTER,(ON SEMICONDUCTOR, MC74HC165ANG)	5
RP6	U32001-000	IC,1K FEED-THROUGH RES NETWORK,16 PIN DIP,(A/B 316B102)	1
RP1-RP5	U32103-000	IC,10K FEED-THROUGH RES NETWORK,16 PIN DIP, [BOURNS 4116R-1-103LF]	5
U56	U40008-000	REGULATOR,5V,100MA,TO-92,[ON-SEMI, MC78L05ABPG]	1
U55	U40012-000	FLIP-FLOP,OCTAL D-TYPE LATCH WITH RESET,[NATIONAL MM74HC273N]	1

5.3.5 Parts List, 200T18G26z5A, Microwave Power Assembly 200 Watt K-Band; A 28051-341

REF. DESIG.	ETM P/N	DESCRIPTION	QUANTITY
W1	E01040-000	RF CABLE, 24" K CONNECTORS, LOW POWER [ASTROLAB MINIBEND K24]	1
	E01227-000	CONDUCTIVE WAVEGUIDE FLANGE GASKET WR-34 [CONTINENTAL, GSK34-1-C]	1
		WR-42 TO COAX ADAPTER(TYPE K), [QUINSTAR, QWA-42S29F]	
A14	E01424-000		1
W6	E01842-000	CABLE ASSY, K-MALE TO K-MALE,12" LONG,(ASTROLAB, MINIBEND K-12)	1
A1	E01865-000	18-26.5 GHZ SSPA, 20DBM, 24DB GAIN,WITH GAIN CONTROL,[KMIC, TBD]	1
	E02091-000	2.9MM MALE TO MALE ADAPTOR [INMET, 5171]	3
A3, A10	E02103-000	WR-42 MAGIC TEE (MEC, K100)	2
A11	E02143-000	RF LOAD WR-42 100 WATTS [PER ETM SPECIFICATION]	1
		ATTENUATOR, 6DB, DC-40GHZ, 2.9MM, 1.4:1 (INMET, 40AH-6	
ATTN1-ATTN3	E02179-000)	3
ATTN4	E02180-000	ATTENUATOR, 10DB, DC-40GHZ, 2.9MM, 1.4:1 (INMET, 40AH-10)	1
A18	E02209-000	WR-42 H-BEND	1
A21, A22	E02210-000	WR-42 U-BEND	2
A2	E02214-000	LOAD, LOW POWER 18-26GHZ WR-42, 5 WATTS [APOLLO, TBD]	1
A23-A26, A33-A35	E02216-000	WR-42 E-BEND EVEN	7
A17	E02217-000	WR-42 COUPLER -30 FWD, -30 REFL, 18-26.5 GHZ	1
A4, A5	E02218-000	WAVEGUIDE PHASE SHIFTER, WR-42 FULL BAND, WITH LOCK [FLANN 20061]	2
A6, A7	E02532-000	TWT 18.0 TO 26.5 GHZ 150W CW FOCUS ELECTRODE (L-3, 8928H-1)	2
A8, A9	E03274-000	COUPLER, REVERSE BROADWALL, WR-42	2
A29, A30	E03275-000	WR-42, 180 H-BEND	2
A19, A20	E03276-000	WR-42, SHORT PIECE	2
A31, A32	E03277-000	WR-42, S-BEND	2
A27, A28	E03278-000	WR-42, E-BEND LONG	2
D1-D4	E20316-000	DETECTOR,ZERO BIAS SCHOTTKY,40 GHZ,POS OUTPUT,(KRYTAR 303AK (P))	4
W2-W5	E20319-000	CABLE ASSY, K-MALE TO K-MALE, 8" LONG,(ASTROLAB, MINIBEND K-8)	4
A15, A16	E20364-000	DIRECTIONAL COUPLER, 10 DB, 18-26.5 GHZ, 3.5 MM,[KRYTAR 262210]	2
A13	E20374-000	COAXIAL ISOLATOR K BAND, 18-26 GHZ,[DITOM D3I-1826]	1
J1, J3, J4	J00532-000	K BULKHEAD CONNECTOR [INMET, 5214]	3
	J18160-000	CONN,1 PIN,FEMALE,20KV,10A,0.180 DIA. LEAD,[CONNECTRONICS 11039-02]	7
	N36220-003	WAVEGUIDE CLAMP WR-42	2

5.3.6 Parts List, 200T26z5G40A, Microwave Power Assembly 200KA, A28051-351

REF. DESIG.	ETM P/N	DESCRIPTION	QUANTITY
W1	E01040-000	RF CABLE, 24" K CONNECTORS, LOW POWER [ASTROLAB MINIBEND K24]	1
	E01149-000	WAVEGUIDE FLANGE GASKET, O-RING, NON- CONDUCTIVE, WR-28, [APOLLO, 93164-28)	1
W6	E01842-000	CABLE ASSY, K-MALE TO K-MALE, 12" LONG, (ASTROLAB, MINIBEND K-12)	1
A3, A10	E02102-000	WR-28 MAGIC TEE (MEC, A100)	2
A1	E02136-000	26.5-40 GHZ SSPA, 28 DBM, 32 DB GAIN, VGA PER SPECIFICATION	1
ATTN2, ATTN3	E02178-000	ATTENUATOR, 3DB, DC-40GHZ, 2.9MM, 1.4:1 (INMET, 40AH-3)	2
		ATTENUATOR, 6DB, DC-40GHZ, 2.9MM, 1.4:1 (INMET, 40AH-6	
ATTN1	E02179-000)	1
ATTN4	E02180-000	ATTENUATOR, 10DB, DC-40GHZ, 2.9MM, 1.4:1 (INMET, 40AH-10)	1
A11	E02253-000	RF LOAD WR-28 100 WATTS 26.5 - 40 GHZ (APOLLO, 17003-01)	1
A23, A24, A36, A37	E02257-000	WR-28 H-BEND	4
A2	E02262-000	LOAD, LOW POWER 26-40GHZ WR-28, 5 WATTS [APOLLO, TBD]	1
A21, A22	E02263-000	WR-28 SHORT U-BEND	2
A25, A26, A33-A35	E02264-000	WR-28 E-BEND EVEN	5
A4, A5	E02320-000	VARIABLE PHASE SHIFTER, WR28, 26.5 - 40 GHZ, 1 FLAT FLANGE & 1 GROOVED FLANGE (APOLLO 15898-X)	2
A6, A7	E02533-000	TWT 26.5 TO 40.0 GHZ 150W CW FOCUS ELECTRODE (L-3, 8929H-1)	2
A27, A28	E03284-000	WR-28, LONG E-BEND	2
A19, A20	E03285-000	WR-28, SHORT STRAIGHT PIECE	2
A31, A32	E03286-000	WR-28, S-BEND	2
A29, A30	E03287-000	WR-28, 180 DEGREE H-BEND	2
A8, A9	E03289-000	WR-28, REVERSE BROADWALL, -30DB, 0.2 DB INSERTION LOSS	2
A17	E08201-000	OUTPUT ARM WR-28 (APOLLO, PER E08201)	1
D1-D4	E20316-000	DETECTOR, ZERO BIAS SCHOTTKY, 40 GHZ, POS OUTPUT, (KRYTAR 303AK (P))	4
W2-W5	E20319-000	CABLE ASSY, K-MALE TO K-MALE, 8" LONG, (ASTROLAB, MINIBEND K-8)	4
		WR-28 TO COAX ADAPTOR, UG 599/U TO 2.8MM K TYPE FEMALE CONNECTOR	
A14	E20321-000	[QUINSTAR QWA-28529F]	1
A15, A16	E20365-000	DIRECTIONAL COUPLER, 10 DB, 26.5-40 GHZ, 2.92MM CONNECTOR, [KRYTAR, 264010K]	2
A13	E20375-000	COAXIAL ISOLATOR, 1.4:1 VSWR, KA BAND 26.5-40 GHZ, [DITOM DF3797]	1
J1-J3	J00532-000	K BULKHEAD CONNECTOR [INMET, 5214]	3
	J18160-000	CONN, 1 PIN, FEMALE, 20KV, 10A, 0.180 DIA. LEAD, [CONNECTRONICS 11039-02]	7
	N36220-004	WAVEGUIDE CLAMP WR-28	2

5.3.7 Parts List, Wiring Kit, 200W KA Band (Glass Fibers); A28052-002

REF. DESIG.	ETM P/N	DESCRIPTION	QUANTITY
A11	E01139-000	LINE FILTER, 15 A T-SECTION, EC [FILTER CONCEPTS SF15L LOW PROFILE]	1
	E30147-020	RIBBON CABLE, 28 AWG,D-SUB 37 PIN FEMALE TO D-SUB 37 PIN FEMALE,[DICAR IAW E30147-000]	1
	F00101-000	WASHER,#4 NAS,(PRO-STAINLESS NAS620C4)	8
	F00107-000	#4 SPLIT LOCK WASHER,SST	4
	F31004-000	NUT,4-40,HX,SMALL PATTERN,MIL-SPEC	4
	G00043-000	HEX STANDOFF ,4-40 THREAD SS,FOR D SUBMIN CONN (PRO STAINLESS, 620013)	4
XJ1	H11072-000	STRAIN RELIEF FOR LINE CORD,(PANEL COMPONENTS 85910051)	1
XF1	H14012-000	FUSE HOLDER,(BUSSMAN HTB-44I)	1
	H15031-000	SILPAD, (BERGQUIST, 1009-104)	1
XR1, XR2	H19032-000	TERM.INS.STANDOFF,TEFLON, 0.312 HX STUD,(CAMBION 5701947020519)	1
P30	J00010-000	CONN,1 PIN,FEMALE,(MOLEX 03-09-1011)	1
P14	J00020-000	CONN,PIN & SOCKET,2 PIN,FEM,(MOLEX 03-09-1027)	1
P12	J00021-000	CONN,FEMALE 2 PIN .063,(MOLEX 03-06-1023)	1
P27	J00023-000	CONN,HOUSING,FEMALE,02 PIN,(MOLEX 5197-N 10-01-3026)	1
P16, P56	J00025-000	HOUSING,2 PIN,FEMALE,0.1 SPACING,7880 SERIES,(MOLEX 10-11-2023)	2
P31	J00033-000	CONN,FEMALE 3 PIN,.063,(MOLEX 03-06-1032)	1
P28	J00034-000	CONN,HOUSING,FEMALE,03 PIN,(MOLEX 5197-N 10-01-3036)	1
P15	J00046-000	CONN,HOUSING,FEMALE,4 PIN,0.1SPACING,7880 SERIES,(MOLEX 10-11-2043)	1
P29, P69	J01010-000	CONN,1 PIN,MALE,.250V (MOLEX 03-09-2011)	1
	J01020-000	CONN,PIN & SOCKET,2 PIN,MALE,(MOLEX 03-09-2021)	1
P13	J01021-000	CONN,MALE 2 PIN .063,(MOLEX 03-06-2023)	1
P32	J01031-000	CONN,MALE 3 PIN,.063,(MOLEX 03-06-2032)	1
XP14, XP30	J03000-000	TERMINAL,PIN & SOCKET TYPE,PIN,FEM,CRIMP,(MOLEX 02-09-1118)	3
XP11, XP13, XP32	J03013-000	CONN,PIN MALE,.063,(MOLEX 002-06-2103)	7
	J04000-000	TERMINAL,PIN & SOCKET TYPE,MALE,CRIMP,(MOLEX 02-09-2118)	2
XP10, XP12, XP31	J04013-000	CONN,PIN FEMALE .063,(MOLEX 002-06-1103)	7
XP15, XP16	J04014-000	TERMINAL PIN HIGH PRESSURE MOLEX 7879 SERIES [MOLEX 08-50-0005] (FOR SERIES 7880 HOUSING 10-11-XXXX)	6
XP27, XP28	J04015-000	PIN,TERMINAL FOR HOUSING CONNECTOR 5.08MM,(MOLEX 5194 SERIES 08-70-1030)	5
	J10264-000	CONN,FEM SOCKET,26 PIN,IDC MASS TERMINATION,(THOMAS & BETTS 609-2601M)	1
	J11240-000	CONN,RIBBON,24 PIN,FEMALE,1A CONTACTS,BLUE, [3M, 3549-1000-/3448-61]	1
P5, P6, P45, P46	J11370-000	CONN,D-SUB,37 PIN,FEMALE,RIBBON (AMPHENOL, G17K37001001EU)	4
P1, P41	J12031-000	CONN,D-SUB,FEMALE,3 PIN,#8 AWG,PLUG,HI POWER [ITT CANNON DAM-3W3S]	2
P9, P10, P49, P50	J12091-000	CONN,D-SUB,9 PIN,FEMALE,CRIMP (ITT CANNON DEU-9S)	4
P2, P3, P34, P42	J12250-000	CONN,D-SUB,25 PIN,FEMALE,CRIMP	4
P75	J12372-000	D-SUB,37 PIN,FEMALE,CRIMP	1
TB1	J13041-000	TERM BLOCK,4 POS,6-32,250V,20A,(BEAU 18004)	1
J3	J17102-000	BNC,BULKHEAD RECEPTACLE,GROUNDED,(AMPHENOL 31-221)	1
XP1	J18054-000	CONTACT,FEMALE,HI PWR,20 AMP,UP TO 12AWG WIRE,[ITT CANNON DM53744-6]	2
	J18073-000	MALE SCREW LOCK,D SUB CONN,(AMP 205980-1)	2

REF. DESIG.	ETM P/N	DESCRIPTION	QUANTITY
P19-P26, P59-P65	J18124-000	CONN,SMA MALE SOLDER ATTACHMENT FOR RG188,(RADIAL. R125.072.001)	15
	J18160-000	CONN,1 PIN,FEMALE,20KV,10A,0.180 DIA. LEAD,[CONNECTRONICS 11039-02]	5
J1	J18162-000	POWER INLET,MALE,16A,250VAC, IEC-320 (PANEL COMPONENTS CORP, 83030400)	1
J2	J18176-000	CONN,D-SUB,15 PIN,FEMALE,CRIMP,(ITT CANNON DAU-15S)	1
P35, XJ2	J18184-000	D-SUB,15 PIN MALE,CRIMP (ITT CANNON DAU-15P)	2
P4, P44	J31011-000	D-SUB,37 PIN,MALE,CRIMP,5A,20 AWG (ITT CANNON DCU-37P)	2
P7, P8, P47	J31012-000	CONN,D-SUB,15 PIN,FEMALE,RIBBON CABLE,W/STRAIN RELIEF,PLASTIC,[AMPHENOL 841-17-DAFR-B15S]	3
	J31014-000	SPRING LATCH KIT,D-SUB,(AMPHENOL 17-529)	9
	N22925-000	MODIFIED KNOB,1/4 SHAFT	1
	N23323-000	TEMPERATURE SENSOR BLOCK	1
	N24373-000	CONNECTOR COVER	1
	N24841-000	PANEL SWITCH SPACER	2
	N31829-000	FERRITE SUPPORT	1
R1, R2	R01166-000	RES,160 OHM,2W,5%,FILM	2
S2, S3	S25002-000	SWITCH,PUSHBUTTON,SPDT,SAFETY DOOR INTERLOCK,DEFEATABLE,(MICRO SWITCH 3AC6)	2
S1	S26026-000	C/B,2 POLE,15A,(AIRPAX IEGH-66-1-61-15.0-C-21)	1
		SWITCH,KEYLOCK,1 POLE,3 POS,SHORTING,THROW,(ILLINOIS LOCK HD5161 AACCM-100-090-041G)WITH KEY E100	1
S4	S32074-000	CORE,FERRITE,ETD 39	2
	T03108-000	PRECISION CELSIUS TEMP SENSOR, TO-220 [NATIONAL LM35DT]	4
U1-U4	U00052-000	WIRE,26 AWG,COAXIAL,RG-188A/U,900V (BELDEN 83269)	8
	W01880-000	WIRE,14 AWG,600V,BLACK, (BELDEN, 35614-0)	8
	W11400-000	WIRE,18 AWG,BLUE,(BELDEN 83009)	4
	W11800-000	WIRE, 22 AWG, BLU, 600V, TEFLON, (BELDEN 83006)	8
	W21600-000	POWER CORD,3 COND,16 AWG,125V,13A,10 FEET,3 PIN MALE TO 3 PIN FEMALE IEC 320-C133 (BELDEN 17503)	1
	W23700-000	CABLE,RIBBON,37 COND,28 AWG,STRANDED,[TYCO, 1-971111-8]	12
	W30054-000	POWER CORD, 250VAC, 20A, 3 CONDUCTOR, FEMALE, STRAIGHT PLUG, 60 DEG C, [INTERPOWER, 70025110250]	1
	W30064-000	CABLE ASSY,IEEE-488,ONE HERMAPHRODITE CONNECTOR,ONE STRAIGHT,1 METER,(ICS 105710)	1
W1-W6	W30104-000	CABLE,GLASS FIBER OPTIC,200 MICRON HCS, (OFS, BC04265-10]	6
B1, B2	Y10029-000	FAN, MAJOR, 230 VAC, 50/60HZ, 220 CFM (SANYO DENKI, 109S303)	2
XB1-B, XB2-B	Y20000-000	FAN CORD,(ROTRON 428056)	2
		FAN FINGER GUARD,MAJOR DC/MAJOR,STEEL WIRE,WELDED,BRIGHT ZINC PLATED	
XB1, XB2	Y20007-000	COMAIR/ROTRON,550272 (FOR Y1001)	2
F1	Z20020-000	FUSE,2A,250V,3AG,SB,(LITTELFUSE 313.002)	1
	Z31022-000	SURGE ARRESTOR,(CPCLARE AC240L)	1

5.3.8 Parts List, VSWR/Foldback Board Assembly, A32363-000

REF. DESIG.	ETM P/N	DESCRIPTION	QUANTITY
	A32363-900	ALTERA FIRMWARE FOR VSWR/FOLDBACK BOARD	1
	B32363-000	VSWR/FOLDBACK BOARD	1
C13, C15	C04105-000	CAP, 0.1MF, +/-20%, 100V, MON [KEMET C331C104M1R5CA]	2
C19	C16103-000	CAP,10MF,35V,AERL,(NICHICON UVR1V100MDA)	1
C16	C30009-000	CAP,22MF,50V,10%,AERL, (NICHICON, UVR1H220MDD)	1
C1, C4, C6, C9, C20-C24	C31016-000	CAP,100PF,200VDC,10%,CER,1% FAILURE,(KEMET CKR05 SERIES W/"V" OPTION)	9
C12, C14	C31032-000	CAP,0.01MF,200VDC,10%,CER,1% FAILURE,(KEMET CKR06 SERIES W/"V" OPTION)	2
C2, C7, C10, C11, C18, C25	C31036-000	CAP,0.1MF,100VDC,10%,CER, (KEMET, M39014/2-1310V)	6
C3, C5, C8, C17	C31040-000	CAP,1MF,50VDC,10%,CER,1% FAILURE,(KEMET CKR06 SERIES W/"V" OPTION)	4
D1-D10, D18-D21	D14454-000	DIODE,AXIAL,(FAIRCHILD SEMICONDUCTOR, 1N4454)	14
D11-D17	D14733-000	ZENER,5.1V,1W,10%,AXIAL,(FAIRCHILD SEMICONDUCTOR, 1N4733A)	7
I2	I10052-000	LED,INDICATOR,RED,4 POSITION,(DIALIGHT, 555-4003F)	1
	J00613-000	PLCC SOCKET, 44 PIN (FCI 54020-44030LF), USE FOR HIGH VIBRATION	1
J2	J10102-000	HEADER,5 PIN,2 ROW,.1 CTR,(SAMTEC TSW-1-05-07-G-D)	1
		CONN,37 PIN,MALE,D-SUB,PCB RIGHT ANGLE, (AMP, 5747252-4)	
J1	J10370-000		1
TP0, TP10, TP20	J16210-000	TEST JACK,BLACK,VERTICAL,(EF JOHNSON 105-0853-001)	3
TP1, TP11, TP21	J16211-000	TEST JACK,BROWN,VERTICAL,(EF JOHNSON 105-0858-001)	3
TP2, TP12, TP22	J16212-000	TEST JACK,RED,VERTICAL,(EF JOHNSON 105-0852-001)	3
TP3, TP13, TP23	J16213-000	TEST JACK,ORANGE,VERTICAL,(EF JOHNSON 105-0856-001)	3
TP4, TP14, TP24	J16214-000	TEST JACK,YELLOW,VERTICAL,(EF JOHNSON 105-0857-001)	3
TP5, TP15, TP25	J16215-000	TEST JACK,GREEN,VERTICAL,(EF JOHNSON 105-0854-001)	3
TP6, TP16, TP26	J16216-000	TEST JACK,BLUE,VERTICAL,(EF JOHNSON 105-0860-001)	3
TP7, TP17, TP27	J16217-000	TEST JACK,VIOLET,VERTICAL,(EF JOHNSON 105-0862-001)	3
TP8, TP18	J16218-000	TEST JACK,GREY,VERTICAL,(EF JOHNSON 105-0863-001)	2
TP9, TP19	J16219-000	TEST JACK,WHITE,VERTICAL,(EF JOHNSON 105-0851-001)	2
Q1-Q4, Q7	Q00243-000	TRANSISTOR,NPN,(ON SEMICONDUCTOR MJE-243)	5
Q5, Q6	Q22907-000	TRANSISTOR,PNP, (ST, 2N2907A) TO-18	2
R30, R31, R34, R37, R44, R51, R56	R01100-000	RES,100 OHM,1/4W,5%,CC,(OHMITE, OD101JE)	7
R28, R29, R33, R36, R55	R01220-000	RES,220 OHM,1/4W,5%,CC,(OHMITE, OD221JE)	5
R49	R01514-000	RES,510 OHM,1/2W,5%,CC,(A/B, RC20GF511J)	1
R17, R23, R24, R26, R27, R32, R35, R46, R54, R62-R64	R02100-000	RES,1K,1/4W,5%,CC,(OHMITE, OD102JE)	12
R7, R14, R21, R48	R02510-000	RES,5.1K,1/4W,5%,CC,(OHMITE, OD512JE)	4
R1, R8, R15, R22, R25, R45,	R03100-000	RES,10K,1/4W,5%,CC,(OHMITE, OD103JE)	12

R47, R57-R61

R66, R67	R04100-000	RES,100K,1/4W,5%,CC,(A/B RC07GF104J)	2
R4, R11, R18	R05100-000	RES,1M,1/4W,5%,CC,(OHMITE, OD105JE)	3
R2, R3, R9, R10, R16, R41, R65	R21200-000	RES,2.00K, 1%,MF,50PPM,(DALE, RN55C2001F)	7
R5, R12, R19, R42	R21249-000	RES,2.49K,1%,MF,100PPM,(DALE RN55D)	4
R38-R40	R23100-000	RES,100K, 1%,MF,100PPM,(DALE RN55D1003F)	3
R6, R13, R20, R43	R30074-000	TRIMPOT,1K,1/2W,10%,CERMET,100PPM,20T,TOP ADJ,(BECKMAN 67W)	4
U1, U2	U02903-000	8PIN DIP, LOW POWER, LOW OFFSET VOLTAGE DUAL COMPARATORS, [NATIONAL, LM2903N]	2
U8	U11165-000	IC,6.5536MHZ CLOCK OSCILLATOR,1/2 SIZE,(ECLIPTEK EC1100HS-6.5536MHZ) (SSD)	1
U7	U13051-000	CONVERTER,OIL,DC/DC,9-18V IN,5V @ 1A OUT,[CONVERSION DEVICES 505S12WFR]	1
U6	U13140-000	IC, BIMOS OPAMP WITH MOSFET INPUT/BIPOLAR OUTPUT, 4.5MGZ (INTERSIL, CA3140EZ)	1
U3, U4	U20148-000	IC,HEX INVERTER,SCHMIDTT TRIGGER,(74HC14) (SSD)	2

5.3.9 Parts List, HPA 200 Watt K-Band W/ 2 L3 Tubes (AR), A33961-000

REF. DESIG.	ETM P/N	DESCRIPTION	QUANTITY
A1	A34032-000	RF DRAWER 200 WATT K-BAND	1
A2	A34036-000	POWER SUPPLY DRAWER 200 WATT K-BAND	1

5.3.10 Parts List, HPA 200 Watt KA-Band W/ 2 L3 Tubes (AR), A33962-000

REF. DESIG.	ETM P/N	DESCRIPTION	QUANTITY
A1	A34033-000	RF DRAWER 200 WATT KA-BAND	1
A2	A34035-000	POWER SUPPLY DRAWER 200 WATT KA-BAND	1

5.4 SAMPLE PROGRAM

```
1000 ! *****
1010 ! *      IEEE-488 COMMUNICATIONS SOFTWARE      *
1030 ! *      7/24/92  AARON D. McCLURE          *
1040 ! *****
1041 DIM F$(80)
1042 DIM A$(80)
1050 CLEAR SCREEN
1060 INPUT "INPUT COMMAND TO SEND TO POWER SUPPLY.  EXIT TO QUIT.",A$
1070 IF A$="EXIT" THEN 1130
1080 OUTPUT 701;A$
1090 IF A$[1,2]<>"RD" THEN GOTO 1060
1095 IF A$[1,1]="*" THEN GOTO 1100
1100 ENTER 701;F$
1110 PRINT "OUTPUT FROM COMMAND ",A$," IS ",F$
1120 GOTO 1060
1130 CLEAR SCREEN
1140 END
```

WARRANTIES: LIMITATION OF LIABILITY

Seller warrants (i) that seller has title to the goods sold and (ii) that Amplifiers (all parts excluding traveling wave and vacuum tubes), Antennas, field monitors, field probes, field analyzers, field analyzer processor units, system controllers, system interlock, power meters, leak detectors, RF conducted probes, RF conducted clamps, Multi-tone, EMI receiver systems, RF down converters, RF conducted immunity systems, conducted immunity accessories, radiated immunity test systems, safety meters, safety sensor heads, tripods, directional couplers, waveguide adapters, termination loads, load attenuators, impedance stabilization networks, and coaxial cables will be free from defects in material and workmanship for a period of three (3) years from date of shipment shown on AR RF/Microwave Instrumentation invoice.

All modules, used in the amplifiers for the 1-6 GHz, 4-18 GHz, 6-18 GHz, all HPM products, and other applications, are hermetically-sealed. This sealing process protects the internal hybrid circuitry from humidity that could compromise the long term reliability of the product. These modules are not field-repairable and should *never* be opened outside of AR's Microelectronics Lab. The modules in these product lines have a security label on two sides of the modules between the housing and lid/cover. If the security label is removed and or cut, the warranty of the module will be voided.

Vacuum tubes in the 'L' series amplifiers, traveling-wave tubes in TWT amplifiers, and power heads will be free from defects in material and workmanship for a period of one (1) year.

Contact AR RF/Microwave Instrumentation for warranty information regarding items not listed.

Seller's sole responsibility in fulfilling these warranties shall be to repair or replace any goods which do not conform to the foregoing warranties or, at seller's option, to give buyer credit for defective goods. The warranty is valid only when used in the country specified at time of order. Warranty service must be obtained from the repair facility designated at that time. If warranty service is not available in the country where the equipment is to be used, it must be returned to AR RF/Microwave Instrumentation. Warranty service will be provided only for defective goods which are returned within the warranty period, freight costs prepaid to AR RF/Microwave Instrumentation or its designated repair facility.

There are no other warranties, express or implied, including any warranty of merchantability or fitness. Seller shall not be responsible for any incidental or consequential damages arising from any breach of warranty.

No person other than an officer of Amplifier Research Corporation, has any authority to bind seller to any affirmation, representation or warranty except as specifically included in the preceding terms and conditions.

