

Operating and Service Manual

3000TP12G18

Model

10031733

Part Number

Serial Number



EC Declaration of Conformity

We; Amplifier Research
160 School House Road
Souderton, PA. 18964

declare that our product(s);

the Models 3000TP12G18 series RF amplifiers

to which this declaration relates is in compliance with the requirements of the:
EEC EMC Directive (89/336/EEC) in accordance with Article 10 (2) of the directive, with the provision that the user must install the equipment as directed by the “Instructions for European EMC Conformity” in the Operating and Service Manual.

This product(s) is in compliance with the requirements of the Low Voltage Directive (72/23/EEC) in accordance with safety standard IEC EN60950 (1995).

The CE marking is affixed on the device according to the EC Directives.

A handwritten signature in blue ink that reads "James M. Maginn". The signature is written in a cursive, flowing style.

James M, Maginn
President

Instructions for European EMC Conformity



It is the responsibility of the user of this equipment to provide electromagnetic shielding, filtering and isolation which is necessary for EMC compliance to Directive 2014/30/EU. The equipment must therefore be operated in a shielded area which provides a sufficient level of attenuation to meet the radiated emissions and immunity specifications. The following minimum levels are suggested for use in accordance with the rated power of the equipment.

Rated Power	Minimum shielding attenuation
100 watts	50 dB
101 - 1000 watts	60 dB
1001 - 10,000 watts	70 dB

Since this equipment is designed to generate high levels of Radio Frequency energy, it is also essential that the user read and follow the “Instructions for Safe Operation” in this manual. If other equipment is operated in the shielded room it may be disturbed by the amplifier.



Der Benutzer dieses Gerätes ist dafür verantwortlich, daß die elektromagnetische Abschirmung und Filterung gewährleistet ist, welche gemäß Richtlinie 2014/30/EU notwendig ist. Das Gerät muß deshalb in einem geschirmten Raum betrieben werden, welcher eine ausreichenden Schirmung bietet, um die Emissions- und Störfestigkeitsspezifikation einzuhalten. Es werden folgenden Minimalwerte der Schirmdämpfung und Filterung in den unterschiedlichen Leistungsklassen empfohlen.

Hochfrequenzleistung	min. Schirmdämpfung
100 Watt	50 dB
101-1000 Watt	60 dB
1001-10.000 Watt	70 dB

Falls andere elektrische oder elektronische Geräte gleichzeitig mit dem Gerät betrieben werden, kann es zu Beeinflussungen kommen. Da das Gerät zur Erzeugung von Hochfrequenzenergie dient ist es daher auch unbedingt notwendig, daß der Benutzer die Sicherheitsvorschriften in der Bedienungsanleitung liest und einhält.



Il est de la responsabilité de l'utilisateur de cet équipement d'assurer la protection électromagnétique, le filtrage et l'isolation nécessaires, afin de se conformer à la directive 2014/30/EU concernant la C.E.M. Par conséquent, cet équipement doit être mis en fonctionnement dans une enceinte d'atténuation suffisante pour satisfaire aux spécifications d'émissivité et de susceptibilité. Pour une utilisation conforme, les niveaux d'atténuation minimums suivants sont suggérés en fonction de la puissance de sortie de l'équipement:

Puissance de sortie	Atténuation minimum de l'enceinte
100 Watts	50 dB
101 à 1.000 Watts	60 dB
1.001 à 10.000 Watts	70 dB

Puisque cet équipement est destiné à générer de forts niveaux R.F., il est essentiel que l'utilisateur se conforme aux instructions de sécurité indiquées dans ce manuel. Tout autre équipement en fonctionnement dans la cage de Faraday peut-être perturbé par l'amplificateur.

INSTRUCTIONS FOR SAFE OPERATION









Observe the following safety guidelines to help ensure your own personal safety and to help protect your equipment and working environment from potential damage.

INTENDED USE

This equipment is intended for general laboratory use in generating, controlling, and measuring levels of electromagnetic Radio Frequency (RF) energy. Ensure that the device is operated in a location which will control the radiated energy and will not cause injury or violate regulatory levels of electromagnetic interference.

SAFETY SYMBOLS

These symbols may appear in your user manual or on equipment.

	This symbol is marked on the equipment when it is necessary for the user to refer to the manual for important safety information. The caution symbol denotes a potential hazard. Attention must be given to the statement to prevent damage, destruction, or harm.
	Dangerous voltages are present. Use extreme care.
	Indicates a terminal intended for connection to an external conductor for protection against electrical shock in case of a fault, or the terminal of a protective earth (ground) electrode.
	Indicates invisible laser radiation—do not view directly with optical instruments.
	Indicates frame or chassis ground connection terminal.
	Indicates alternating current.
	Indicates this product must not be disposed of with your other household waste.
	Indicates that the marked surface and adjacent surfaces can attain temperatures that may be hot to the touch.

EQUIPMENT SETUP PRECAUTIONS

 Review the user manual and become familiar with all safety markings and instructions. Protection provided by the equipment may be impaired if used in a manner not specified by AR RF/Microwave Instrumentation (AR).

- Follow all lifting instructions specified in this document.
- Place the equipment on a hard, level surface.
- Do not use the equipment in a wet environment, for example, near a sink, or in a wet basement.

- Position your equipment so that the power switch is easily accessible.
- Leave 10.2 cm (4 in) minimum of clearance on all vented sides of the equipment to permit the airflow required for proper ventilation. Do not restrict airflow into the equipment by blocking any vents or air intakes. Restricting airflow can result in damage to the equipment, intermittent shut-downs or safety hazards.
- Keep equipment away from extremely hot or cold temperatures to ensure that it is used within the specified operating range.
- While installing accessories such as antennas, directional couplers and field probes, take care to avoid any exposure to hazardous RF levels.
- Ensure that nothing rests on your equipment's cables and that the cables are not located where they can be stepped on or tripped over.
- Move equipment with care; ensure that all casters and/or cables are firmly connected to the system. Avoid sudden stops and uneven surfaces.

BEFORE APPLYING POWER

Your AR equipment may have more than one power supply cable. Use only approved power cable(s). If you have not been provided with a power cable for the equipment or for any AC-powered option intended for the equipment, purchase a power cable that is approved for use in your country. The power cable must be rated for the equipment and for the voltage and current marked on the equipment's electrical ratings label.



Incorrectly installing or using an incompatible line voltage may increase the risk of fire or other hazards. To help prevent electric shock, plug the equipment and peripheral power cables into properly grounded electrical outlets. These cables are equipped with three-prong plugs to help ensure proper grounding. Do not use adapter plugs or remove the grounding prong from a cable.

Do not modify power cables or plugs. Consult a licensed electrician or AR trained service technician for equipment modifications. Always follow your local/national wiring rules.



Do not operate the equipment if there is physical damage, missing hardware, or missing panels.

SAFETY GROUND



This equipment is provided with a protective earth terminal. The mains power source to the equipment must supply an uninterrupted safety ground of sufficient size to attach wiring terminals, power cord, or supplied power cord set. ***DO NOT USE this equipment if this protection is impaired.***

INSTRUCTIONS FOR SAFE OPERATION

HAZARDOUS RF VOLTAGES



The RF voltages on the center pin of an RF output connector can be hazardous. The RF output connector should be connected to a load before AC power is applied to the equipment. Do not come into contact with the center pin of the RF output connector or accessories connected to it. Place the equipment in a non-operating condition before disconnecting or connecting the load to the RF output connector.

ACOUSTIC LIMITATIONS

If equipment noise exceeds 80dB, ear protection is required.

MAINTENANCE CAUTION

Adjustment, maintenance, or repair of the equipment must be performed only by qualified personnel. Hazardous energy may be present while protective covers are removed from the equipment even if disconnected from the power source. Contact may result in personal injury. Replacement fuses are required to be of specific type and current rating.

ENVIRONMENTAL CONDITIONS

Unless otherwise stated on the product specification sheet, this equipment is designed to be safe under the following environmental conditions:

- Indoor use
- Altitude up to 2000m
- Temperature of 5°C to 40°C
- Maximum relative humidity 80% for temperatures up to 31°C. Decreasing linearly to 50% at 40°C.
- Main supply voltage fluctuations not to exceed $\pm 10\%$ of the nominal voltage or minimum and maximum autoranging values.
- Pollution degree 2: Normally non-conductive with occasional condensation. While the equipment will not cause hazardous condition over this environmental range, its performance may vary.

EQUIPMENT CONTAINING LASERS



AR Field Probes (FL/PL Series) and Field Analyzers (FA Series) are Class 1 laser products containing embedded Class 4 lasers. Under normal use, the laser radiation is completely contained within the fiber optic cables and poses no threat of exposure. Safety interlocks ensure that the laser is not activated unless the cables are properly connected. Always exercise caution when using or maintaining laser products. Do not view directly with optical instruments.

RF ANTENNAS

- This equipment (antenna or antenna assembly) may be heavy, requiring two persons to lift. Use caution when installing or removing unit. Follow all equipment setup and lifting instructions specified in this document.
- Ensure connectors are appropriate for intended operation. Connectors are specified in the user manual and product specification sheet.
- Do not exceed the maximum RF input level stated in the specifications. Refer to the user manual and product specification sheet to determine the applicable RF levels.
- Excessive RF input could damage the equipment or connectors, causing safety hazards.
- When in operation, the RF voltages on the antenna elements can be hazardous. Do not come into contact with the antenna or elements when the RF input connector is connected to a live RF source.
- To avoid injury to personnel and accidental damage to power amplifier or antenna, disable the RF output of power amplifier before connecting or disconnecting the input connection to the antenna.
- Perform periodic inspections of antenna and field probe systems to verify calibration due date, proper operation, and overall condition of equipment.

RACK MOUNTED TWT MODELS

Some TWT models are supplied without the removable enclosure offered for benchtop use. These rack-mountable models may be supplied with either carry handles or slides and front handles installed. Follow all lifting instructions specified in this document and installation instructions supplied in the TWT user manual.

LIFTING INSTRUCTIONS FOR AR EQUIPMENT

Because most products must be handled during distribution, assembly and use, the risk of serious injury due to unsafe product handling should be a fundamental consideration of every user. An authoritative guideline for eliminating unwarranted risk of injury caused by lifting is provided by the NIOSH Work Practices (Publication #94-110) available at:



<https://www.cdc.gov/niosh/docs/94-110/pdfs/94-110.pdf>.

In general, observe the following guidelines for lifting a weight of 50 lb or more:

- Use lifting eye (for floor standing) or side handles (table top) to lift unit only.
- Use equipment of adequate capacity to lift and support unit.
- If using forklift to move unit, be sure forks are long enough to extend beyond the side of the unit.
- For additional information, follow the link specified above.

ADDITIONAL WARNINGS & NOTES



WARNING:

This equipment operates at potentially lethal voltages. Only trained, qualified personnel should operate, maintain, or service it.



CAUTION:

The information in this document was obtained from reliable sources and was believed to be accurate at the time of publication. Since subsequent modifications to the machine may have been made, use this information only as a guide. Carefully compare the unit's actual configuration and operation to the descriptions in this manual before you undertake to operate, service, or modify this machine. Any variance or modification should be noted, dated, and initialed in the discrepant part of all manuals on hand for future reference. If you have technical or editorial comments you wish to make to the manufacturer, please write them on photocopies of the relevant sheets.

NOTE: The contents of this document are the property of the manufacturer and this document is delivered on the express condition that it not be disclosed, reproduced in whole or in part, or used for manufacture for anyone other than the manufacturer without its written consent, and that no right is granted to disclose or so use any information in this document.



Suggested Periodic Maintenance for TWT Amplifiers

1. Keep monthly log of the voltages, currents and temperatures as shown on Menus. Also record Date, “Console” and “Operate” hours. Take readings in Operate mode with the gain at zero (0%) percent. Leave unit in Operate mode for 20 minutes (Max Duty if Pulsed Unit), and then record data. Review the log to identify trends and contact factory if required.
2. Keep monthly log of performance with active RF. At mid-band frequency, with Gain set to 100%, apply RF drive that will provide rated power. This will help indicate if the gain or power is changing and if the traveling wave tube or pre-amp needs service. Record the following:
 - a. RF Drive Level
 - b. Forward Power
 - c. Reverse Power
 - d. Body Current (I_w)
 - e. Sample Port Power reading (if possible).
3. Remove air intake filter and clean using compressed air and/or vacuum cleaner.
4. Ensure air inlet and outlet are unobstructed.
5. Check that AC Input connections are secure. Make sure the AC cable is not damaged or deteriorated.
6. Check that both input and output RF connections (waveguide or coax) are connected tightly and un-damaged.

TABLE OF CONTENTS

TABLE OF CONTENTS	i
1. DESCRIPTION AND SPECIFICATIONS	1
1.1 TWTA Description	1
1.2 Suggested Applications.....	1
1.3 Specifications.....	1
1.5 Test Data Sheet	1
2. THEORY OF OPERATION	5
2.1 Design of the Amplifier	5
2.2 Description of the RF Subsystem	5
2.3 Description of the Power Supply Subsystem.....	5
2.3.1 Low Voltage Power Supply Module:	5
2.3.2 Logic and Control Module:.....	6
2.3.3 Power Factor Corrector Module	6
2.3.4 Power Board Assembly:	6
2.3.5 Diode/Cap Assembly	6
2.3.6 High Voltage Filter	6
2.3.7 Heater Power Supply Module.....	6
2.3.8 Grid Modulator Module.....	6
3. OPERATION	7
3.1 Warnings and Cautions	7
3.2 Installation	8
3.2.1 Unpacking.....	8
3.2.2 Mounting.....	8
3.2.3 Cooling Requirements	9
3.2.4 AC Line Power Connections	9
3.2.5 RF Connections.....	10
3.3 Front Panel Features	11
3.4 Rear Panel Features	12
3.5 Front Panel Display and Soft Keys.....	16
3.5.1 Overview.....	16
3.5.2 Menu Screens.....	18
3.5.3 Setup Screens.....	18
3.5.4 Sleep Mode	19
3.5.5 Warning Screens	19
3.5.6 Miscellaneous Screens	20
3.6 Initial Turn On and Warm-up Procedure	21
3.7 Remote IEEE-488 Operation	22
3.8 RF Operation	27
3.9 TWTA General Considerations	28
4. MAINTENANCE.....	31
4.1 Safety Warning	31
4.2 Unauthorized Repairs	31
4.3 Preventive Maintenance.....	31

4.4	Troubleshooting	33
4.5	Non-Repairable Modules	33
4.6	Recommended Spare Parts	34

5. TECHNICAL DOCUMENTATION 35

5.1	Schematics	35
5.2	Parts Lists.....	35
5.3	Top Level Build Tree.....	35
5.4	Sample Program for IEEE-488 Communication	35

FIGURES

3-1	Front Panel Features	11
3-2	Rear Panel Features	12
3-3	Soft Key Locations	16
3-4	Menu Tree.....	17

TABLES

3-1	Front Panel Features	11
3-2	Rear Panel Features	12
3-3	Catalog of IEEE-488 Commands.....	22
3-4	Catalog of Status Codes	24
3-5	Catalog of Fault Codes	25
3-6	Catalog of System State Codes	26
3-7	Catalog of *STA?; Response Codes	26
3-8	Catalog of *STB?; Response Codes	27
3-9	Catalog of Heater Auto Off Time Delay Codes.....	27

1. DESCRIPTION AND SPECIFICATIONS

This manual provides operating, interfacing and selected service information pertinent to Amplifier Research Model 3000TP12G18 Broadband Microwave Amplifier. The Model 3000TP12G18 is a 3000 watt pulsed Ku-band traveling-wave tube amplifier (TWTA).

1.1 TWTA DESCRIPTION

The amplifier uses a 3,000 watt traveling-wavetube (TWT) to provide 3,000 watts minimum output over the TWT amplifier's full bandwidth, higher in other parts of the band. The amplifier is well suited for applications where instantaneous bandwidth and high gain are required. The amplifier is completely self-contained and packaged for standard 19-inch rack mounting.

Primary power is 190-260 volts 50-60 Hz., single phase. An efficient switching power supply design provides minimum power consumption. A fast regulation control loop and a high degree of filtering ensure performance within specifications over a wide range of operating conditions. The amplifier is fully enclosed, and the upper and lower panels of the rack mountable amplifier are interlocked to reduce the likelihood of accidental contact with high voltage.

1.2 SUGGESTED APPLICATIONS

- RF Susceptibility testing
- Antenna and component testing
- Equipment calibration
- General laboratory instrumentation

1.3 SPECIFICATIONS

Refer to the AR RF/Microwave Instrumentation Data Sheet at the end of this section for detailed specifications.

1.5 TEST DATA SHEET

A Test Data Sheet for a specific unit is prepared at the time of manufacture and is included with the unit's copy of this manual.



3000TP12G18

- Pulse Amplifier
- M1-M8
- 3000 Watts
- 12GHz-18GHz

Features

The Model 3000TP12G18 is a self contained, forced air cooled, broadband traveling wave tube (TWT) microwave amplifier designed for pulse applications at low to moderate duty factors where instantaneous bandwidth and high gain are required. A reliable TWT provides a conservative 3000 watts minimum peak RF pulse power at the amplifier output connector. Stated power specifications are at the fundamental frequency.

The amplifier's front panel digital display shows forward and reflected average power output or forward and reflected peak power, plus extensive system status information accessed through a series of menus via soft keys. Status indicators include power on, warm-up, standby, operate, faults, excess average or peak reflected power warning and remote. Standard features include a built-in IEEE-488 (GPIB) interface, 0dBm input, TTL Gating, VSWR protection, gain control, RF output sample port, auto sleep, plus monitoring of TWT helix current, cathode voltage, collector

voltage, heater current, heater voltage, baseplate temperature and cabinet temperature. Modular design of the power supply and RF components allow for easy access and repair. Use of switching mode power supplies results in significant weight reduction.

Housed in a stylish contemporary cabinet, the amplifier provides readily available pulsed RF power for a variety of applications in Test and Measurement, (including EMC RF pulse susceptibility testing), Industrial and University Research and Development, and Service applications. AR also offers a broad range of amplifiers for CW (Continuous Wave) applications.

The export classification for this equipment is 3A999.d. These commodities, technology or software are controlled for export in accordance with the U.S. Export Administration Regulations. Diversion contrary to U.S. law is prohibited.

See Model Configurations for alternative prime power, packaging, and special features.

Model 3000TP12G18 Typical Peak Pulse Power Output

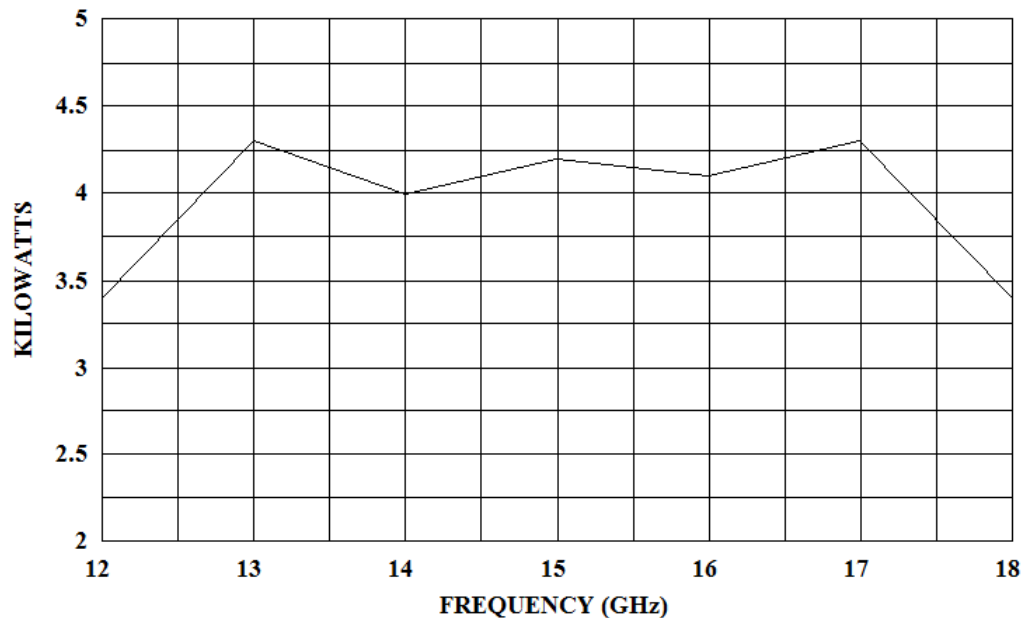

AR RF/Microwave
Instrumentation
160 School House Rd
Souderton, PA 18964
215-723-8181

For an applications engineer call: 800.933.8181

www.arworld.us



3000TP12G18

- Pulse Amplifier
- M1-M8
- 3000 Watts
- 12GHz-18GHz

Specifications

POWER (Fundamental), Peak Pulse, @ Output: Nominal, 3800 watts; Minimum, 3000 watts

FLATNESS: ±10 dB maximum

FREQUENCY RESPONSE: 12–18 GHz

INPUT FOR RATED OUTPUT: 1.0 milliwatt maximum

GAIN (at maximum setting): 65 dB minimum

GAIN ADJUSTMENT (continuous range): 35 dB minimum

INPUT IMPEDANCE: 50 ohms, VSWR 2.5:1 maximum

OUTPUT IMPEDANCE: 50 ohms, VSWR 2.5:1 typical

MISMATCH TOLERANCE: Output pulse width foldback protection at peak reflected power exceeding 1000 watts. Will operate without damage with any magnitude and phase of source and load impedance. May oscillate with unshielded open due to coupling to input. Should not be tested with connector off. See S2M special option, if applicable.

NOISE POWER DENSITY:
 (pulse on) Minus 55 dBm/Hz (maximum);
 Minus 65 dBm/Hz (typical)
 (pulse off) Minus 140 dBm/Hz (typical)

HARMONIC DISTORTION: Minus 8 dBc maximum

PRIMARY POWER: See Model Configurations

Model Configurations

E Package Alternatives. May select an alternative from the following [E1C or (E1C and E2S) and/or E3H]:

E1C Cabinet: Without outer enclosure for rack mounting, size (W x H x D) 49 x 22 (5U) x 68 cm, 19 x 8.75 (5U) x 26.8 in., Subtract approximately 11 kg, 25 lbs, for removal of outer enclosure.

E2S Slides: slides installed, add approximately 2 kg, 5 lbs.

E3H Handles: Front pull handles installed.

P Primary Power: Must select one primary power from the following [P1 or P2]

P1 208 VAC ± 10% 3-phase, 50/60 Hz, 2.0 KVA maximum

P2 190-260 VAC single phase, 50/60 Hz, 2.0 KVA maximum

S Special Features: May select a special feature (extra cost) from the following [S1R or S2M]:

S1R Reflected power sample port, type N female connector on rear panel. Forward and reflected sample port calibration data supplied on disk in Excel format at 51 points, evenly spaced over specified frequency response.

S2M Special Mismatch Tolerance Operation: Amplifier will permit up to 1.9kW reflected power at maximum 8μs pulse width and .8% duty, without VSWR trip or fold-back. Exceeding 1.9kW reflected power will cause the unit to truncate pulse within 2μs. For pulses beyond 8μs, exceeding 1kW will cause the unit to truncate the pulse. If exceeding .8% duty with reflected

PULSE CAPABILITY:

Pulse Width 0.07–50 microseconds.
 Pulse Rate (PRF) 100 kHz maximum
 Duty Cycle 4% maximum.
 RF Rise and Fall 30 ns max (10% to 90%).
 Delay 300 ns maximum from pulse input to RF 90%

Pulse Width Distortion ±30 ns maximum (50% points of output pulse width compared to 50% points of input pulse width)

Pulse Off Isolation 80 dB minimum, 90 dB typical
 Pulse Input TTL level, 50 ohm nominal termination

CONNECTORS:

RF input: Type N female, rear panel
 RF output: Type WR62 waveguide flange, rear panel
 RF output forward sample port :
 Type N female, rear panel
 Pulse input: Type BNC female, rear panel
 GPIB: IEEE-488 female, rear panel
 Interlock: DB-15 female, rear panel

COOLING: Forced air (self contained fans), air entry and exit in rear.

SIZE: 50.3 x 26 x 81 cm (19.8 x 10 x 31.9 in)

WEIGHT: 52 kg (115 lbs)

EXPORT CLASSIFICATION: 3A999.d

power exceeding 1kW, the amplifier will truncate the pulse within 2μs. The amplifier will continue to truncate pulses until reflected power dissipates from outside source. Operation with truncated pulses for >250mS will result in latched “Truncated Pulse Fold Back” displayed on screen and over the remote interface, including an audible alarm. Operation with truncated pulses for 5 to 10 seconds will cause “Over Reverse” fault and a shutdown of high voltage and the amplifier.

Model Number	Features		
	E	P	S
3000TP12G18	Base model	P2	–
M1	E1C	P2	–
M2	E3H	P2	–
M3	E1C & E3H	P2	–
M4	E1C & E2S	P2	–
M5	E1C & E2S & E3H	P2	–
M6	–	P2	S1R
M7	–	P1	S2M
M8	–	P1	–

Model number example: Model 3000TP12G18M2 would have option E3H front pull handles installed.

2. THEORY OF OPERATION

2.1 DESIGN OF THE AMPLIFIER

The Model 3000TP12G18 TWT amplifier consists of two main subsystems. The power supply subsystem and the RF subsystem, which are discussed in Sections 2.2 and 2.3, respectively.

These two subsystems work in conjunction with the control system. The heart of the microprocessor control system is the CPU board (A25450-000). The microprocessor control system supervises the power supply and RF gain controls and processes operator input by enabling communication with a host computer over the IEEE-488 interface or local control through the front panel display and buttons.

Communication of operational status with the amplifier is via fiberoptic links to the HPA interface assembly (A25444-001). The HPA interface assembly provides fault monitoring capabilities for discrete fault logic and analog readbacks. This assembly also contains the digital to analog circuits for controlling the solid-state pre-amp's (SSPA) gain adjustment.

2.2 DESCRIPTION OF THE RF SUBSYSTEM

The TWTA consists of two stages of RF amplification: a solid-state pre-amp (SSPA) assembly with adjustable gain (E02792-100) and a traveling-wave tube amplifier (E02591-001).

The type N RF input connector is located on the rear panel. The RF input is fed to the input connector on the solid-state pre-amp. The solid-state pre-amp's output drives the RF input of the TWT. The RF output of the TWT is a WR-62 waveguide. The output is directed through a high-power coupler (E00467-100) which provides forward and reverse sample ports before directing the RF output through the rear panel.

The reverse port on the directional coupler is connected to a crystal detector, whose output is used for VSWR protection by the power supply logic board, for VSWR measurement in the leveling loop, and for reverse power measurement on the HPA interface board.

The forward port output is split by a -10 dB coupler. The output is connected to a crystal detector via a pad. The output of the crystal detector is used on the HPA interface board to measure forward power. The -10dB port of the coupler is connected to the RF sample port on the rear panel.

Amplifier gain is determined by the solid-state pre-amp, which has a voltage-controlled attenuator. The CPU board determines the output of a digital-to-analog converter (DAC) on the HPA interface board. This analog reference is directed to the SSPA for the purpose of controlling the gain of the amplifier.

2.3 DESCRIPTION OF THE POWER SUPPLY SUBSYSTEM

The TWT power supply is of modular construction. All modules are connected through a motherboard, and are very easy to replace. This makes maintenance fast and easy.

2.3.1 Low Voltage Power Supply Module:

AC/DC converter which generates the +15VDC/-15VDC/+5VDC needed for housekeeping.

2.3.2 Logic and Control Module:

This module controls the power supply, monitors all the voltages and currents of the unit, and provides protection for the power supply and the TWT.

2.3.3 Power Factor Corrector Module

This switching module forces the line current waveform to follow the line voltage waveform. This minimizes the line harmonics and maintains the power factor near unity. The output of this module provides the 375VDC bus used by the high voltage switching power supply.

2.3.4 Power Board Assembly:

This module contains a 120kHz switching buck regulator, and a 60kHz H-Bridge, which converts the DC regulated voltage to an AC signal. This regulated AC waveform is applied to the primary of the high voltage transformer. Control is by the pulse width modulation board. The post regulator, which is a fast linear regulator for the helix voltage, is also included in this module.

2.3.5 Diode/Cap Assembly

This module contains the high voltage transformer and the high voltage rectifiers.

2.3.6 High Voltage Filter

This module contains the high voltage capacitors for the cathode and the collector voltages. This module filters ripple from the high voltage rectifiers, monitors the cathode and collector voltages, and sends a feedback signal to the post regulator.

2.3.7 Heater Power Supply Module

Powers the TWT DC heater. It uses +15VDC input and provides isolated -6.3 VDC at cathode potential

2.3.8 Grid Modulator Module

The Grid module generates two floating voltages at cathode potential, and switches its output between those voltages, at a rate of up to 100kHz. Bias and pulse top voltage for the TWT grid are provided by the Modulator Assembly. Interconnects between the power supply modules are through a motherboard. It is installed in a finned heat sink assembly to which the modules are bolted. The incoming cabinet air cools the heat sink.

3. OPERATION

3.1 WARNINGS AND CAUTIONS

Throughout this manual, the symbol:



WARNING:

indicates that a hazard exists that may result in personal injury or loss of life.



CAUTION:

indicates that failure to follow procedures may result in damage to the equipment.



WARNING: DANGER - High Voltage Present:

Electrical equipment in this TWTA generates and stores high-voltage energy that can result in fatal electrocution. Do not operate the TWTA with covers or the front panel removed.

Service work must be performed only by technicians thoroughly familiar with the high-voltages present in microwave tube amplifiers in general, and with this equipment in particular.

Never handle the TWT leads or the high-voltage connectors unless the unit has been unplugged and it has been positively established that the high-voltage filter capacitors have been discharged to a *known* safe level.



WARNING: Safety Ground

Improper grounding of this equipment can result in electric shock. The TWTA must be operated only with a line cord with a safety ground wire. It is the user's responsibility to ascertain that the power connector is properly wired and that the power outlet is grounded.



WARNING: Explosive Atmosphere

To avoid explosion, never operate this TWTA in an explosive atmosphere. This equipment is not certified for operation in an explosive atmosphere.

3.2 INSTALLATION

3.2.1 Unpacking

Upon receiving the TWTA, unpack the unit and inspect it for obvious signs of external damage. If damage is observed, notify the carrier and contact an authorized service representative.

Save and store the shipping container in case the unit needs to be returned in the future for calibration or repair.

CAUTION:



The RF amplifier should not be operated if there is physical damage, missing hardware or missing panels.

3.2.2 Mounting

NOTE: Due to the weight of the unit, the removal of the amplifier from the cabinet or rack is a two-person operation.

Disconnect power and any other cables. Remove any screws connecting the HPA to a rack or cabinet. Carefully remove the HPA from the rack or cabinet. If slide rails are used, depress the buttons on each slide rail to remove the unit from the rack.

CAUTION:



Never rack mount the TWTA using the front panel alone. The chassis is likely to be damaged unless its weight is supported. Slide rails can be used in a rack mount configuration.

For rack mount installation of multiple units, the units should be separated vertically by at least 1 3/4 inches. This will allow room for necessary support rails, facilitate installation and removal of the units, and help prevent overheating.

3.2.3 Cooling Requirements

The TWTA is provided with a number of cooling fans. It is important that air movement around the rear of the unit be unobstructed.



CAUTION:

Do not position the TWTA in such a way that the air intakes or outlets are blocked, or that the exhaust air flow is directed into air intakes. See Paragraph 3.5 for location of air intakes and air outlets. Make sure that the intake air is 45°C or below. Great care must be taken to minimize any exhaust air restrictions. Avoid mounting heat-producing equipment near the TWTA, especially below the TWTA's air intakes. Pay special attention to the location of RF loads and lossy coaxial cable connected directly to the TWTA which may conduct heat back to the TWTA. Use supplemental fans as necessary to cool these components, directing this heat away from the rear of the TWTA. Failure to provide adequate cooling can result in the unit shutting down from overtemperature conditions. The TWTA dissipates approximately 1.5-2.5 kilowatts when in the Operate mode.

3.2.4 AC Line Power Connections

AC line power connection to the Power Supply Chassis is made at the AC inlet J1, which is a male, 4 pin receptacle, MS3102A22-22P. The power connector pinout is as follows.

AC IN Pinout

	A	AC
	B	Neutral
	C	Safety Ground
	D	NC

WARNING:



Improper grounding of this equipment can result in electric shock. The TWTA must be operated only with a line cord with a safety ground wire. It is the user's responsibility to ascertain that the power connector is properly wired and that the power outlet is grounded.

CAUTION:



Main supply voltage fluctuation not to exceed the nominal voltage range of 190-260 VAC.

3.2.5 RF Connections

The RF output connector is WRD-62 waveguide.

The RF input connector is type N.

CAUTION:



Never operate the TWTA without a matched output load rated for at least 8,000 watts, peak and/or 450W continuous. The TWTA is not provided with an output isolator. Full reflected power may irreparably damage the TWT. Even with no drive, "looping" oscillation can result in RF output high enough to damage the tube if it is operated without a load. The VSWR detection circuit is provided to protect the tube from *progressive* failure or mismatch of the output load; it should not be relied on for protection from the absence of a load.

CAUTION:



If an external isolator is installed at the output of the TWTA, either the isolator should have a load capable of dissipating the full output of the TWTA or the isolator load should be provided with a temperature sensing switch. The temperature switch should be normally closed, self-resetting, and with a temperature rating such that there is no possibility of damaging the load by overheating before the switch opens.

3.3 FRONT PANEL FEATURES

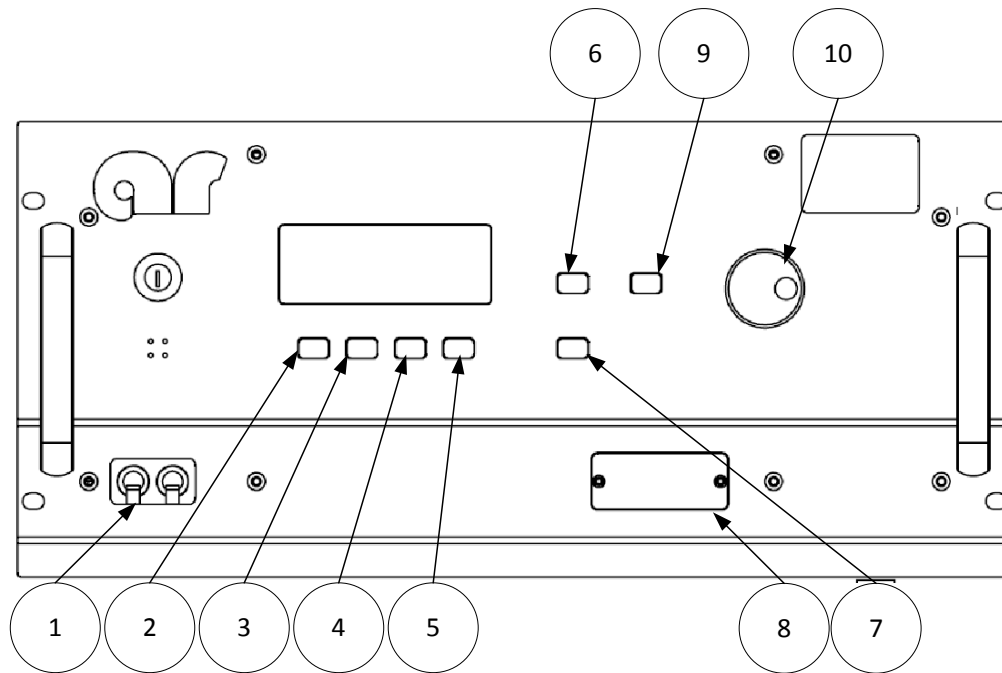

Figure 3-1. Front Panel Features

Table 3-1. Front Panel Features

Label	Title	Function
1	Main Power	Switchable 15 amp circuit breaker
2-5	S1...S4	"Soft Key" pushbuttons: various menu selection functions
6	Standby	Pushbutton: turns high voltage and heater off
7	Exit	Pushbutton: terminate various menu selection routines and returns to the previous menu level
8	Emergency Switch Cover	Provides access to emergency bypass switches, which permit manual control of the amplifier.
9	Operate	Pushbutton: turns on high voltage when all faults and heater time delay have cleared.
10	Adjust	Rotary knob used as an input device to change values of a variety of parameters

3.4 REAR PANEL FEATURES

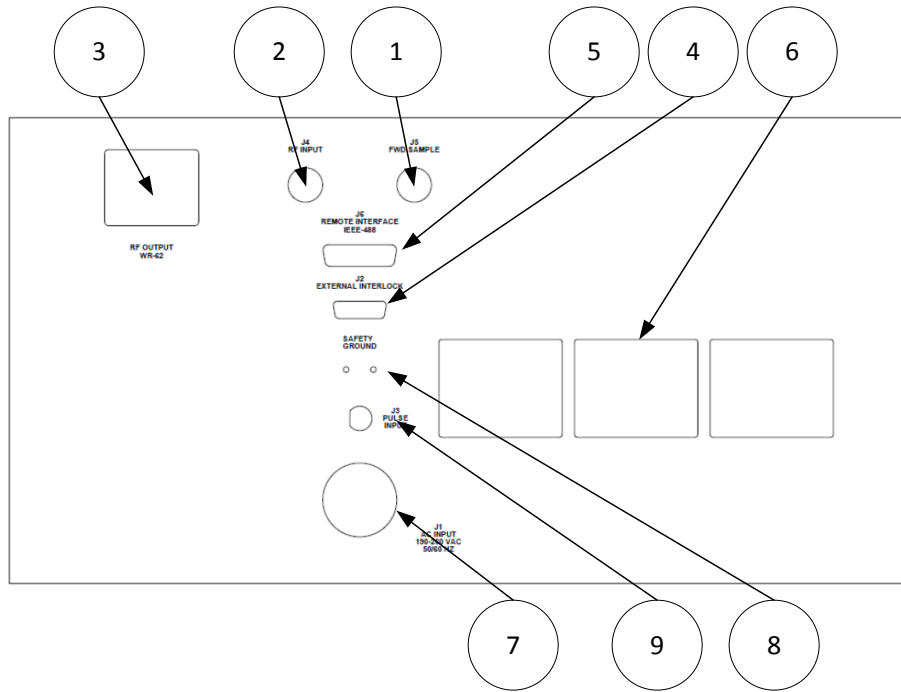

Figure 3-2. Rear Panel Features

Table 3-2. Rear Panel Features

Label	Title	Function
1	FWD Sample	Forward Power Sample Port: -50dB coupling factor, Type N female
2	RF Input	RF Input: Type N female
3	RF Output	RF Output: Type N female
4	External Interlock	Connector for remote interlock and inhibit functions: D-Sub 15-pin female
5	IEEE-488	Remote Control Connector: IEEE-488 Connector
6	Air Intake	Convection cooling inlet
7	AC Input	Circular AC Input connector: 190-260VAC
8	Safety Ground	Internal and External Safety Ground Stud
9	Pulse Input	Modulator Pulse Input: BNC female

Menu screens - The screens at the highest level are called menu screens. There are five menu screens. At power on, the MENU 1 screen is displayed. Each of the menu screens has the soft key S4 labeled MORE. The MORE key (S4) causes the next menu screen to appear. From MENU 5, MORE causes MENU 1 to reappear. In short, MORE permits scrolling through the menu screens. The EXIT key returns display to MENU 1 from any other menu screen.

The menu screens display system status and parameter levels. They are configured as follows:

Menu	Functions
MENU 1	Forward power (watts, dBm or bar graph) Reverse power (watts, dBm or % forward power) System status (if a latched fault exists, MENU 1 is displayed with the system shutdown message)
MENU 2	Console hours (active when AC power is on) Operate hours (active when HV is on)
MENU 3	Power supply temperature (°C or °F), both units TWT baseplate temperature (°C or °F), both tubes
MENU 4	Heater voltage (Ef), HPA #1 Heater current (If), HPA #1 Collector voltage (Eb), HPA #1 Grid voltage (Eg), HPA #1 Cathode voltage (Ek), HPA #1 Helix current (Iw), HPA #1
MENU 5	Heater voltage (Ef), HPA #2 Heater current (If), HPA #2 Collector voltage (Eb), HPA #2 Grid voltage (Eg), HPA #2 Cathode voltage (Ek), HPA #2 Helix current (Iw), HPA #2

Help Screens - On most of the menu screens, soft key S3 is labeled HELP. If S3 is selected, a message describing the functions of that screen will be displayed. Use the ADJUST knob to scroll through the message. The EXIT key will return you to the screen from which the help screen was called.

Setup Screens - From MENU 2, S1 (labeled SETUP) selects the first of several setup screens, SETUP 1. This allows the user to manually shut off the heater power supply and put the HPA into Sleep Mode. Pressing S1 (SET) toggles between On and OFF. Pressing MORE brings up the SETUP 2 screen. This toggles display of temperature parameters between Fahrenheit and Celsius degrees. Pressing S1 (SET) changes the selection. The setting displayed when the screen is exited will be retained. Pressing MORE again brings up the SETUP 3 screen, which allows a choice of displaying forward power in strip-chart form, or in dBm or watts. Pressing MORE again brings up SETUP 4, which allows a choice of dBm or watts for displaying reflected power. Pressing MORE again brings up SETUP 5, which allows entering the desired number of alarm beeps and the desired beep volume. S1 (SET) toggles between parameters, and the adjust knob is used to enter the data. Setup 6 allows the IEEE-488 address to be set. Pressing MORE returns you to SETUP 1. EXIT returns you from any of the setup screens to MENU 2.

Sleep Mode - The Sleep Mode feature allows the user to selectively shut off the heater module of the power supplies. This can be done manually through the front panel or remotely via the computer interface. This is typically used during extended periods of remote operation to improve tube life, by turning off the filaments (Sleep Mode activated). This eliminates excessive STANDBY hours on the TWTs while still permitting remote capability to turn on the amplifier.

After activating the Sleep Mode, screen will display **Cooling On** while heaters cool down. **System Off** notifies user that the amplifier is in Sleep Mode

To deactivate Sleep Mode, press the ON soft key. Amplifier will return to MENU 1. When deactivating the Sleep Mode, the heaters will require approximately a 5 minute heater time delay. Wait the full 5 minutes prior to selecting OPERATE.

Warnings Screens - From MENU 3, S1 (labeled WARNINGS) selects WARNINGS 1 which allows the operator to enter the maximum forward power. The existing value is between brackets[]; pressing SET puts arrows >< around the value, indicating that the adjust knob is active. The effect of the warning setpoint is as follows: if the forward power exceeds the setpoint, the audible alarm will sound (if configured in SETUP 3).

This warning will be repeated every thirty seconds until the over forward power condition is cleared. In addition, a warning message will appear on line 3 (the status line) of MENU 1. In the event that the alarm is heard, the operator should go to MENU 1 to determine the cause.

Pressing more brings up WARNINGS 2, which allows the under forward power setpoint to be entered. Adjusting this to the minimum value causes -OFF- to be selected, disabling this alarm.

In WARNINGS 3, the maximum reverse power level is set. Note that these are warning levels at which the beep sounds; the actual maximum reverse power level that generates a system fault is set in hardware in the TWT power supply HPA Logic and Control module (A16485).

MORE brings up WARNINGS 4, which allows input of the maximum cabinet temperature. Entering this parameter is performed as above.

MORE brings up WARNINGS 5, identical to the previous screen except that it deals with the maximum TWT collector block temperature. If either parameter exceeds the setpoint, the audible alarm will sound every 30 seconds (if configured), and a warning message will appear on line 3 of MENU 1.

From WARNINGS 5, MORE brings up WARNINGS 6, which permits setting the maximum helix current. Any helix current above this setpoint will result in an audible alarm (if configured), repeated every 30 seconds; and a warning message is displayed on the status line of MENU 1.

Pressing MORE again returns display to WARNINGS 1. As before, pressing EXIT from any of the warnings screens returns display to MENU 3.

Info Screen - From MENU 2, S2 (labeled INFO) selects a screen that displays the RF sample port calibration factors at various frequencies across the band. In addition, this screen displays the model number, serial number and firmware revision information which may be required by a service representative when providing technical assistance. The EXIT key returns the display to MENU 2.

Event Screen - From MENU 4, S2 (labeled EVENT) provides a display of events logged by the control system. These events include AC power-up, heater warm-up, change from standby to operate, faults, and resets. The events are stored in a first-in-first-out (FIFO) software buffer that has room for 100 events; as new events are logged, the older ones are discarded.

System Shutdown Screen - In the event of a system shutdown due to a fault, refer to Table 3-5. The MENU screen is replaced by a screen indicating the nature of the fault. Softkey S4 (labeled OK) is implemented as a reset key; pressing S4 brings back the MENU screens. Line 3 of MENU 1, which normally displays the operational state of the TWTA, is used as a fault display line until the fault is cleared. Most faults turn HV off. Faults that do not turn off HV are specified in Table 3-5. When such faults are cleared, the system will automatically resume the standby state and users may again select the Operate mode.

Some faults (EXTERNAL INHIBIT) will turn off the grid of the tubes to disable RF output while the fault is being displayed on the screen. HV will remain on during these faults. Once the fault is corrected, the fault will clear and the system will turn RF back on automatically. This automatic return to operation is provided for selected faults due to influences external to the TWTA.

Factory Service Screens - A number of screens intended for factory service and calibration are behind passwords and are not accessible to the user.

System Malfunction Screens - A number of screens are reserved to display error messages. These messages are not normally seen and indicate a malfunction of the TWTA. System malfunction messages include the following:

- Database corrupt
- Communication failure
- Cannot restore
- CU line voltage too low to operate. System shutdown

In the event that one of these appears, shut off the TWTA and contact an authorized service representative before proceeding.

CAUTION:



Attempts to operate the TWTA despite control unit problems may result in loss of the static RAM database and calibration information.

3.5 FRONT PANEL DISPLAY AND SOFT KEYS

3.5.1 Overview

The purpose of the front panel display is to permit the operator to access extensive information about the condition and operation of the TWTA. To accomplish this, a number of informational screens are programmed. It is important for the operator to be able to select the screen with the required information. Screen selection is accomplished by pressing an appropriate soft key, or by pressing the EXIT key (See Figure 3-3). When a soft key is active, its function is displayed on the bottom line of the display. Figure 3-4 (next page) provides a “roadmap” for navigating between the screens.

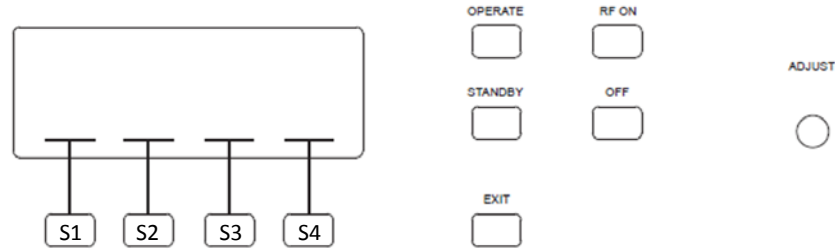

Figure 3-3. Soft Key Locations

Soft Keys S1- S4

The current function of each soft key is displayed in the screen area immediately above it.

- S1 Entry to Setup screens 1-6 from Menu 2
Entry to Warning screens 1-6 from Menu 3
- S2 Entry to Faults screen from Menu 4
- S3 Entry to contextual help screens from top-level Menus 1 through 4
- S4 Entry to next level down; from the lowest level, returns to the top.

EXIT

Returns to the top level from within a menu sequence.

ADJUST

This knob is used to:

- Set the amplifier gain
- Scroll through lists of menu items
- Select parameter values for change
- Enter calibration values

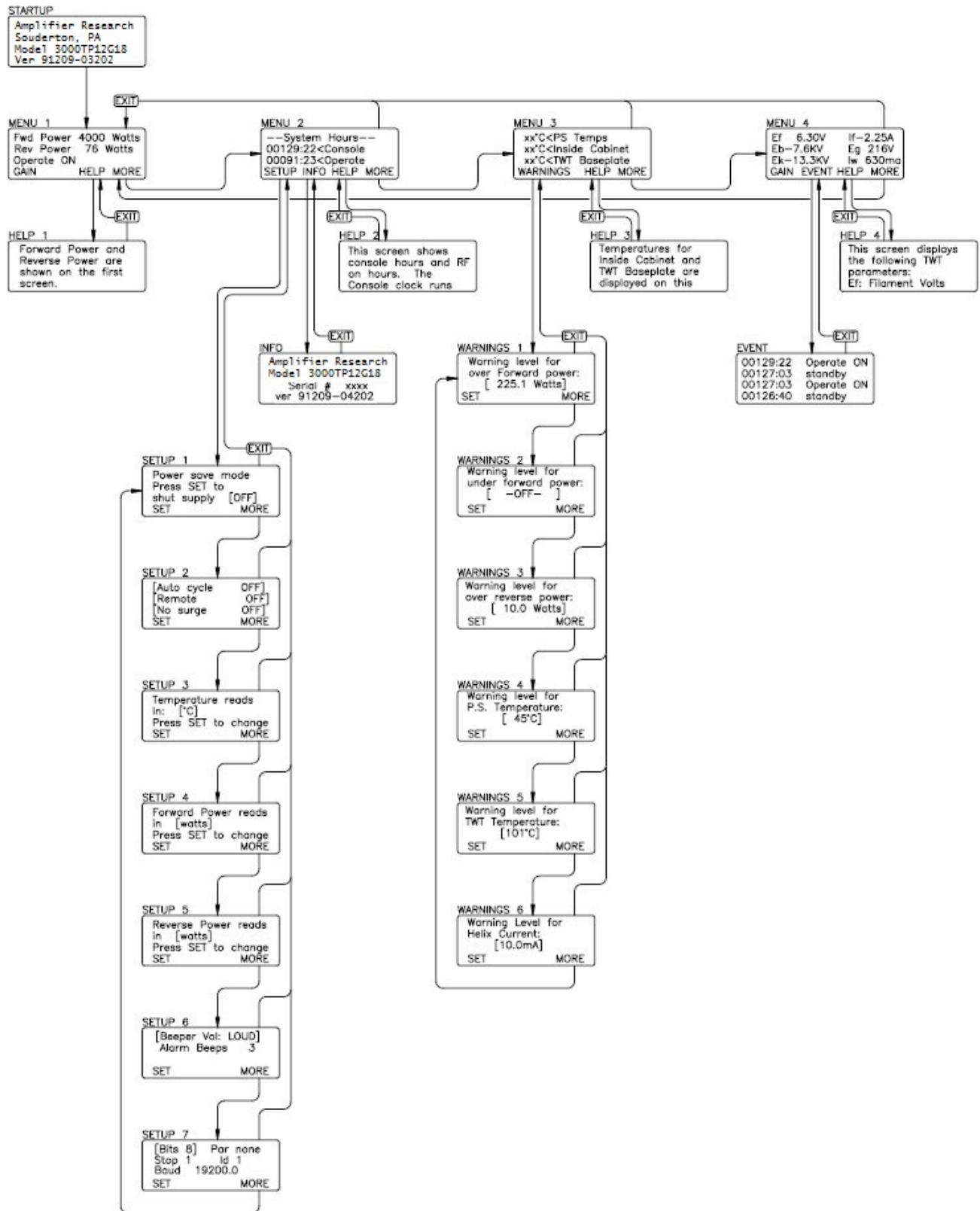

Figure 3-4. Menu Tree

3.5.2 Menu Screens

Menu Screens - The screens at the highest level are called menu screens. There are four menu screens. At power on, the MENU 1 screen is displayed. Each of the menu screens has the soft key S4 labeled MORE. The MORE key (S4) causes the next menu screen to appear. From MENU 4, MORE causes MENU 1 to reappear. In short, MORE permits scrolling through the menu screens. The EXIT key returns display to MENU 1 from any other menu screen.

The menu screens display system status and parameter levels. They are configured as follows:

MENU 1	Forward power (bar graph, watts, or dB)
	Reflected power (bar graph, watts, dB or % forward power)
	System status (if a latched fault exists, MENU 1 is displayed with the system shutdown message)
MENU 2	- System Hours -
	Console hours (active when main power circuit breaker is on, represents TWT filament hours)
	Operate hours (active when HV is on)
MENU 3	Power supply temperature (°C or °F)
	Cabinet temperature (°C or °F)
	TWT baseplate temperature (°C or °F)
MENU 4	Heater voltage (Ef)
	Heater current (If)
	Collector voltage (Eb)
	Cathode voltage (Ek)
	Helix current (Iw)
	Grid voltage (eg) (If Applicable)

NOTE: Readings and headings on Menu 1-4 will vary depending on the type of HPA. Check test data.

Help Screens S3 - On each of the menu screens 1 ,2, 3 and 4 soft key S3 is labeled HELP. If S3 is selected, a message describing the functions of that screen will be displayed. Use the ADJUST knob to scroll through the message. The EXIT key will return you to the screen from which the help screen was called.

3.5.3 Setup Screens

Setup Screens “Menu 2” - Labeled SETUP selects the first of the setup screens.

SETUP 1: allows the user to manually shut off the heater power supply and put the HPA into “Sleep Mode” (see section 3.5.4). Pressing S1 (SET) toggles between ON and OFF. Pressing MORE again brings up the SETUP 2.

SETUP 2: toggles Auto Cycle On/OFF and Remote. Pressing S1 (SET) changes the selection. The setting displayed when the screen is exited will be retained.

Pressing MORE brings up the next screen, SETUP 3.

Auto Cycle: When primary power is restored after an interruption, the system will return to the On state that existed before the interruption. For example, if the TWTA is at RF On, and Auto Cycle is selected, it will automatically recycle the amplifier to turn RF On after a primary power interruption.

The control system will warn you at power up if Auto cycle is enabled. To cancel, simply press either the RF Off or Standby key.

Remote: When Remote is off, a device connected to the TWTA computer interface may monitor the amplifier's status but may not control the Operate, Standby, RF Off, RF On, or Reset keys. When Remote is On, the external device has full control of the amplifier for safety reasons. Pressing the RF Off or Standby keys cancels the Remote mode, and causes the system to revert to local control.

SETUP 3: toggles display of temperature parameters between Fahrenheit and Celsius degrees. Pressing S1 (SET) changes the selection. The setting displayed when the screen is exited will be retained. Pressing MORE again brings up the next screen, SETUP 4.

SETUP 4: allows a choice of displaying forward power in stripchart form, or in dBm or watts. Pressing MORE again brings up the next screen, SETUP 5.

SETUP 5: allows a choice of displaying reflected power in stripchart form, % of forward power, or in dBm or watts. Pressing MORE again brings up the next screen, SETUP 6.

SETUP 6: toggles the desired number of alarm beeps and the desired beep volume. S1 (SET) toggles between parameters, and the adjust knob is used to enter the data. Pressing MORE again brings up the next screen, SETUP 7.

SETUP 7: allows the RS-422/485 address to be set. Pressing MORE again brings the user back to SETUP 1.

3.5.4 Sleep Mode

Sleep Mode (see Section 3.5.3) - The Sleep Mode feature allows the *user* to selectively shut off the heater module of the power supply. This can be done manually through the front panel or remotely via the computer interface. This is typically used during extended periods of *remote* operation to improve tube life, by turning off the filaments (Sleep Mode activated). This eliminates excessive STANDBY hours on the TWTs while still permitting remote capability to turn on the amplifier.

To activate Sleep Mode locally, Press the MORE soft key to get to MENU 2. At MENU 2 press the SETUP soft key to get to SETUP 1. At SETUP 1 press SET to activate Sleep Mode (turn heater and fan off). The system will ask **Are you sure?** Press SET again.

After activating the Sleep Mode, screen will display **Cooling On** while heaters cool down. **System Off** notifies user that the amplifier is in Sleep Mode

To de-Activate Sleep Mode locally, press the ON soft key to de-activate Sleep Mode. Amplifier will return to MENU 1. When de-activating the Sleep Mode the heaters will require at least a 3 minute heater time delay. Wait the full 3 minutes prior to selecting OPERATE.

3.5.5 Warning Screens

Warnings Screens "Menu 3" - Labeled **WARNINGS** selects the first of six setup screens

WARNINGS 1: allows the operator to enter the maximum forward power. The existing value is between brackets []; pressing SET puts arrows >< around the value, indicating that the adjust knob is active. The effect of the warning setpoint is as follows: if the forward power exceeds the setpoint, the audible alarm will sound (if configured in SETUP 5). This warning will be repeated every thirty seconds until the over forward power condition is cleared. In addition, a warning message will appear on line 3 (the status line) of MENU 1. In the event that the alarm is heard, the operator should go to MENU 1 to determine the cause. Pressing MORE brings up the next screen, Warnings 2.

WARNINGS 2: allows the under forward power set-point to be entered. Adjusting this to the minimum value causes -OFF- to be selected, disabling this alarm. Pressing MORE again brings up the next screen, Warnings 3.

WARNINGS 3: allows for the maximum reflected power level to be set. Note that these are warning levels at which the beep sounds; the actual maximum reflected power level that generates a system fault is set in hardware in the TWT power supply HPA Logic and Control Module. Pressing MORE brings up the next screen, Warnings 4.

WARNINGS 4: allows input of the maximum power supply temperature. Entering this parameter is performed as above. Pressing MORE brings up the next screen, Warnings 5.

WARNINGS 5: allows input of the maximum TWT collector block temperature. If either parameter exceeds the setpoint, the audible alarm will sound every 30 seconds (if configured), and a warning message will appear on line 3 of MENU 1. Pressing MORE brings up the next screen, Warnings 6.

WARNINGS 6: permits setting the maximum helix current. Any helix current above this setpoint will result in an audible alarm (if configured), repeated every 30 seconds; and a warning message is displayed on the status line of MENU 1. Pressing MORE again returns display to WARNINGS 1. As before, pressing EXIT from any of the warnings screens returns display to MENU 3.

3.5.6 Miscellaneous Screens

Info Screen “MENU 2 S2” - (labeled **INFO**) selects a screen that displays the RF sample port calibration factors at various frequencies across the band. In addition, this screen displays the model number, serial number and firmware revision information, which may be required by a service representative when providing technical assistance. The EXIT key returns the display to MENU 2.

Event Screen “Menu 4 S2” - Labeled **EVENT** provides a display of events logged by the control system. These events include AC power-up, heater warm-up, change from standby to operate, faults, and resets. The events are stored in a first-in-first-out (FIFO) software buffer that has room for 100 events; as new events are logged, the older ones are discarded.

System Shutdown Screen - In the event of a system shutdown due to a latched fault (i. e., a fault such as body over-current or power low line that requires a reset), the MENU screen is replaced by a screen indicating the nature of the fault. Softkey S4 (labeled OK) is implemented as a reset key; pressing S4 brings back the MENU screens. Line 3 of MENU 1, which normally displays the operational state of the TWTA, is used as a fault display line until the fault is cleared. When the fault clears the system will automatically resume the standby state and high voltage on will be enabled once again.

Factory Service Screens - A number of screens intended for factory service and calibration are behind passwords and are not accessible to the user.

System Malfunction Screens - A number of screens are reserved to display error messages. These messages are not normally seen and indicate a malfunction of the TWTA. System malfunction messages include the following:

- Database corrupt
- Communication failure
- Cannot restore
- CU line voltage too low to operate. System shutdown

In the event that one of these appears, shut off the TWTA and contact an authorized service representative before proceeding.

CAUTION:



Attempts to operate the TWTA despite control unit problems may result in loss of the static RAM database and calibration information.

3.6 INITIAL TURN ON AND WARM-UP PROCEDURE

Before Applying Power

- Verify that the equipment line voltage is compatible with the TWTA.

NOTE: If the user does not have a 5VDC max TTL signal pulse connected to the pulse input BNC connector, there will be no RF output.

- Install the TWTA as discussed in Section 3.2. Provide an RF generator to the RF input Type N connector. Set RF generator level below -50dBm and set desired frequency in specified range. Connect a load suitable for 8000 watts peak operation to the output connector. The load VSWR should be less than 2.0:1. A power meter and suitable attenuators may be connected to the RF sample port. (Refer to RF sample port calibration factors on the rear of the unit or on the Info screen in MENU 2). These show the relationship between the amplifier output power and the RF sample port power as a function of frequency. When only the power of the fundamental frequency is to be measured and when operating near rated power use filters, a frequency selective receiver, or a spectrum analyzer to reduce the harmonic content of the measured level.
- Switch on the MAIN POWER circuit breaker. The fan will operate. Allow three minutes for the filaments on the TWTs to warm up.
- The front panel display will show several identification messages and then MENU 1 screen. The third line will indicate the heater time delay is active. Allow the heater warm-up delay to expire. Line three will indicate STANDBY / READY.
- Push S4 (MORE) three times to go to MENU 4. Verify that the heater voltage and current are near their nominal levels. The values of these parameters at the time the TWTA left the factory are logged on the test data sheet.
- Push the OPERATE push-button. Stay in Menu Screen 4. You will now see the cathode and collector voltages rise. Verify that the collector and cathode voltages are near nominal. The values of these parameters at the time the TWTA left the factory are logged on the test data sheet.
- Set Gain to 0%. Push RF ON, check the helix current (I_w). The helix current should be close to the nominal value for no RF drive. The value of this parameter at the time the TWTA left the factory is logged on the test data sheet.
- Push S4 (MORE) or EXIT to get to Menu 1 .
- Set the TWTA gain to maximum.

- Adjust the RF generator to slowly increase the RF drive toward 0 dBm to reach the desired forward power on the display and power meter (connected to the forward sample port). The forward power display will become active, with a maximum reading when peak power output is achieved.

An alternate procedure is to pre-set the gain to a minimum, set the RF generator to 0 dBm and then slowly increase the TWTA gain to set the desired RF output level.

- Observe that the helix current is sensitive to the RF drive level of the TWT. It is at a minimum with no RF drive. The helix currents with no drive and with rated RF output mid-band are logged on the test data sheet. The value of the helix current is a good qualitative indicator of RF drive present.
- To shut the system down, push RF OFF and then STANDBY. Allow the TWTA to cool down until the TWT temperature drops below 50°C, then turn off main power.

3.7 REMOTE IEEE-488 OPERATION

The TWTA is provided with an IEEE-488 interface that permits remote emulation of OPERATE, STANDBY, and RESET push-buttons as well as access to parameter measurements, system faults, gain adjustment and control unit status. The following tables summarize the commands and the return codes.

Table 3-3. Catalog of IEEE-488 Commands

Command	Function	Units	Response format
RDSTAT	Returns status code of processing of previous command (see Table 3-4)		STATUS=[]
RDFLT	Returns system fault code (see Table 3-5)		flt=[]
OPERATE;	Emulates OPERATE push-button		
STANDBY;	Emulate STANDBY push-button		
POWER:OFF;	Emulate STANDBY push-button		
SYSTEM:ON;	Emulates pressing the System ON button from System OFF (Exit Sleep Mode)		
SYSTEM:OFF;	Emulates pressing the Power Save button. (Enter Sleep Mode)		
RESET;	Emulates RESET softkey		
RDS/N	Returns serial number		s/n=[]
RDCONHR	Returns console hours		ConHr=[]
RDRFHR	Returns RF hours		RfHr=[]
RDEK1	Returns cathode voltage, HPA1	KV	Ek=[]
RDEK2	Returns cathode voltage, HPA2	KV	Ek=[]
RDEB1	Returns collector voltage, HPA1	KV	Eb=[]
RDEB2	Returns collector voltage, HPA2	KV	Eb=[]
RDEG1	Return grid voltage, HPA1	V	Eg=[]
RDEG2	Return grid voltage, HPA2	V	Eg=[]
RDEF1	Returns heater voltage, HPA1	V	Ef=[]
RDEF2	Returns heater voltage, HPA2	V	Ef=[]
RDIF1	Returns heater current, HPA1	A	If=[]
RDIF2	Returns heater current, HPA2	A	If=[]
RDIW1	Returns helix current, HPA1	mA	Iw=[]
RDIW2	Returns helix current, HPA2	mA	Iw=[]
RDTMPTWTHPA1F	Returns TWT temp (°F), HPA1	°F	TWTHPA1F=[]F

Command	Function	Units	Response format
RDTMPTWTHPA2F	Returns TWT temp (°F), HPA2	°F	TWT HPA2F=[]F
RDTMPTWTHPA1C	Returns TWT temp (°C), HPA1	°C	TWTHPA1C=[]C
RDTMPTWTHPA2C	Returns TWT temp (°C), HPA2	°C	TWTHPA2C=[]C
RDTMPPSHPA1F	Returns power supply temp (°F), HPA1	°F	PSHPA1F=[]F
RDTMPPSHPA2F	Returns power supply temp (°F), HPA2	°F	PSHPA2F=[]F
RDTMPPSHPA1C	Returns power supply temp (°C), HPA1	°C	PSHPA1C=[]C
RDTMPPSHPA2C	Returns power supply temp (°C), HPA2	°C	PSHPA2C=[]C
RDTWTOTF	Returns TWT overtemp warning setpoint (°F)	°F	TWTOTF=[]F
STWTOTF	Sets TWT overtemp warning setpoint (°F)	°F	
RDTWTOTC	Returns TWT overtemp warning setpoint (°C)	°C	TWTOTC=[]C
STWTOTC	Sets TWT overtemp warning setpoint (°C)	°C	
RDPSOTF	Returns power supply overtemp warning setpoint (°F)	°F	PSOTF=[]F
SPSOTF	Sets p. s. overtemp warning setpoint (°F)	°F	
RDPSOTC	Returns p. s. overtemp warning setpoint (°C)	°C	PSOTC=[]C
SPSOTC	Sets p. s. overtemp warning setpoint (°C)	°C	
RDIWOC	Returns helix overcurrent warning setpoint	mA	lwOC=[]
SIWOC	Sets helix overcurrent warning setpoint	mA	
RDLOGIC	Returns logic state code (see Table 3-6)		Sys=[]
RDA	Returns gain	%	A=[]
SA	Sets gain	%	
RDHTDREM	Returns remaining heater time delay	sec.	HTD=[]s
RDPOD	Returns forward power out (dBm)	dBm	Po=[]dBm
RDPOW	Returns forward power out (W)	watts	Po=[]W
RDPRD	Returns reverse power out (dBm)	dBm	Pr=[]dBm
RDPRW	Returns reverse power out (W)	watts	Pr=[]W
RDPOHID	Returns over forward power warning setpoint (dBm)	dBm	Pohi=[]dBm
SPOHID	Sets over forward power warning setpoint (dBm)	dBm	
RDPOLOD	Returns under forward power warning setpoint (dBm)	dBm	Polo=[]dBm
SPOLOD	Sets under forward power warning setpoint (dBm)	dBm	
RDPOHIW	Returns over forward power warning setpoint (W)	watts	Pohi=[]W
SPOHIW	Sets over forward power warning setpoint (W)	watts	
RDPOLOW	Returns under forward power warning setpoint (W)	watts	Polo=[]W
SPOLOW	Sets under forward power warning setpoint (W)	watts	
RDPRHID	Returns over reverse power warning setpoint (dB)	dBm	Prhi=[]dBm
SPPRHID	Sets over reverse power warning setpoint (dBm)	dBm	
RDPRHIW	Returns over reverse power warning setpoint (W)	watts	Prhi=[]W
SPRHIW	Sets over reverse power warning setpoint (W)	watts	
RDHTRAUTOOFF	Returns heater to auto off delay	hours	
SHTRAUTOOFF	Sets heater auto off delay (see Table 3-9)		
*IDN?;	Returns the product model number		[]
*STA?;	Returns status string (see Table 3-7)		[]
*STB?;	Returns status string (see Table 3-8)		[]

Table 3-4. Catalog of Status Codes

(The **RDSTAT** command causes the TWTA to return a string in the form **STATUS=[code]**, where **[code]** is an ASCII number whose meaning is given below)

Status Code	Meaning
0	No command was given or last command was successful.
1	Last command successful.
2	Last command is in process.
3	Last command failed to complete. Time-out.
10	Last command failed. Invalid command.
11	Last command failed. Data was unparseable.
20	Last set command failed. Data was beyond high limit.
21	Last set command failed. Data was beyond low limit.
22	Last set command failed. Data was out of range
23	Last set command failed. Data was wrong polarity
50	Last command failed. Local system does not have remote enabled.
60	Command not allowed
901	Assert error: invalid table argument *
902	Assert error: invalid table argument *

* Please call a service representative if you observe this error.

Table 3-5. Catalog of Fault Codes

(The **RDFLT** command causes the TWTA to return a string in the form **flt=[code]**, where **[code]** is an ASCII number whose meaning is given below)

Fault Code	Meaning	Fault Code	Meaning
0	No fault	72	FIL NOT READY2
40	FIL NOT READY1	73	LOW LINE2
41	LOW LINE1	74	CATH O/VOLTAGE2
42	CATH O/VOLTAGE1	75	BODY O/CURRENT2
43	BODY O/CURRENT1	76	CATH U/VOLTAGE2
44	CATH U/VOLTAGE1	77	ID_BOARD2
47	COLL U/VOLTAGE1	79	COLL U/VOLTAGE2
48	INVERTER FAULT1	80	INVERTER FAULT2
49	INTERLK OPEN1	81	INTERLK OPEN2
50	TUBE ARC1	82	TUBE ARC2
51	TWT OVER TEMP1(h)	83	TWT OVER TEMP2(h)
52	CABINET O/TEMP1(h)	84	CABINET O/TEMP2(h)
54	EXTERNAL INHIBIT1	86	EXTERNAL INHIBIT2
55	OVER REV POWER1	87	OVER REV POWER2
58	Panel Open1	90	Panel Open2
59	latched fault1	91	latched fault2

Table 3-6. Catalog of System State Codes

(The **RDLOGIC** command causes the TWTA to send a string containing an operational state code consisting of 4 ASCII characters representing hex digits. The response is in the form **Sys:[w][x][y][z][eol]** where the hex values of *[w]*, *[x]*, *[y]* and *[z]* are formed as shown below)

z bit	Meaning
0 (LSB)	High voltage on
1	Transmit on
2	Remote mode
3 (MSB)	Fault

y bit	Meaning
4 (LSB)	Heater time delay expired
5	Under forward power warning
6	Foldback active
7 (MSB)	Inhibit mode

x bit	Meaning
8 (LSB)	External inhibit
9	Interlock open
10	(not used)
11 (MSB)	(not used)

w bit	Meaning
12 (LSB)	(not used)
13	Sleep Mode Active
14	HPA #1 power supply off or failed
15 (MSB)	HPA #2 power supply off or failed

Table 3-7. *STA?; Response Codes

(The command ***STA?;** causes the TWTA to send a string indicative of the current system state)

*STA?; response	Meaning
SLEEP	Sleep Mode active (heater off)
WARM-UP	System is in heater time delay.
STANDBY	System is ready to allow high voltage on
OPERATE	High voltage is on and beam is on
FAULT	High voltage is off and system requires reset

Table 3-8. *STB?; Response Codes

(The command ***STB?**; causes the TWTA to send a string containing an operational state code consisting of 2 ASCII characters representing hex digits. The response is in the form **STATUS:[x][y][eol]** where the hex values of [x] and [y] are formed as shown below)

y bit	Meaning
0 (LSB)	Power status; always 1(power on)
1	Standby status; 0 if not in standby, 1 if in standby
2	Operate status; 0 if not in operate, 1 if in operate
3 (MSB)	Fault status; 0 if no fault, 1 if fault exists

x bit	Meaning
4 (LSB)	Mode switch; always 1 (reset)
5	Blank switch; always 1 (off)
6	Blank status; always 0 (off)
7 (MSB)	Not used; always 0

Table 3-9. Catalog of Heater Auto Off Time Delay Codes

Argument	Meaning
0	0.5 hour heater auto off time delay
1	1.0 hour heater auto off time delay
2	1.5 hour heater auto off time delay
3	2.0 hour heater auto off time delay
4	2.5 hour heater auto off time delay
5	3.0 hour heater auto off time delay

Command syntax is in this form:

<command mnemonic> <parameter> <carriage return>

where;

<command mnemonic> consists of one of any valid command found in Table 3-3.

<parameter> (as applicable) consists of one ASCII space character followed by a number.

<carriage return> consists of an ASCII carriage return.

All commands are case sensitive.

The system will return parameter values, fault codes, and status codes regardless of whether remote is enabled. The parameter value is returned as a string of 20 characters or less, consisting of a label, =, and a value. For example, outputting the command RDEF to the TWTA would result in the TWTA sending back the string **Ef=6.03** (assuming the heater voltage is 6.03 volts). Units are usually not returned; see Table 3-3 for the units.

If remote is not enabled, set commands and commands to the system logic (i. e., OPERATE;, STANDBY;, or RESET;) will not be accepted.

It is recommended that the **RDSTAT** command be used to provide the host program with a report on how a command was processed.

A small sample program that can send commands and receive the strings returned by the TWTA is included in Section 5.6. It is written in Hewlett-Packard's "Rocky Mountain" BASIC. The program assumes that the IEEE-488 bus is at address 7 and that the address of the TWTA is 01.

Remote operation is determined by the application (software) program in the system controller. This application program will aid the user in generating the Command Codes and displaying/monitoring the Status Codes. Consult the application program users instructions for Remote operation procedure.

The application program should issue only one string at a time. After each functional command is issued the status should be checked to ensure that the command has been properly executed. The application program should allow sufficient time for the function to be completed before checking the status.

The application program should facilitate checking the status just prior to issuing a command - since the status could have been changed by a fault condition of the amplifier or by operator activation of the amplifier. Periodic checking of the status is also recommended.

3.8 RF OPERATION

NOTE: If the user does not have a 5VDC max TTL signal pulse connected to the pulse input BNC connector, there will be no RF output.

The RF chassis is provided with a front-panel BNC connector which must be connected at all times to generate RF output. The impedance of the pulse gate input is approximately 50 ohms.

For Pulsed operation, provide a TTL pulse signal from a pulse generator at the BNC connector on the rear panel of the RF chassis. In pulse mode the signal will be used for pulsing the beam of the TWT and hence the RF output. As compared with providing a pulsed RF input, pulsing the beam of the TWT offers low noise between pulses. It also offers reduced prime power consumption for low duty factor pulsing, since the beam current is off most of the time.

Best performance is obtained when the input RF drive is set at or just below the level which causes peak power output. Do not set input drive above 0 dBm

CAUTION:



Input drive above +10 dBm may damage the unit.

The reverse (reflected) power level should remain below 10% of the forward power, assuming that the output is properly matched.

3.9 TWTA GENERAL CONSIDERATIONS

This section is intended to offer some guidelines regarding operation, storage and use of Amplifier Research TWTAs.

Storage: TWTAs, as with other electronic equipment, are best stored in a benign environment at reasonably constant temperature. Service life is not improved by periodic operation.

Availability: For critical missions, and after long periods of storage, it is recommended that TWTA operation be checked sufficiently in advance of the mission to permit repair if required. Though service life is not improved by periodic operation, users experiencing amplifier trip due to body over current may benefit by periodically operating a unit with high voltage and grid on, but no rf drive. Such operation for about one hour on a weekly basis should effectively reduce nuisance tripping. Since the cathode structure has finite life, extended periods of non-functional operation of TWTAs is not recommended. An alternate approach, if periodic trip off has been observed, is to operate the unit without rf input for 1-2 hours before planned functional operation, resetting the unit after occasional trip off.

Cooling during Operate Mode: AR TWTAs have their air outlets and inlets on the rear panels. It is important to prevent the heated air, which is expelled from the TWTA's air outlets, from being recycled into the air inlets. Applications should have a clearance behind the TWTA of at least two feet for single bench top units and at least three feet for the higher power units, or the heated air should be ducted away.

Operation in Standby Mode: Standby mode for TWTAs readies the unit for operation. In this mode the filaments are on but the high voltage is off. TWTAs should not be left in this Standby mode for extended periods. Where practical, operational procedures should limit the time on Standby mode to less than approximately one hour. (See *Explanation of....*, below)

Operate Turn on: When selecting the Operate mode, when high voltage is first turned on, there may be some internal TWT arcing which can cause protective circuits to deselect the Operate mode, thereby returning the unit to the Standby mode. There may be a report of body over-current fault. In either case, if there is no other contraindication, the Operate mode may be selected again. This procedure may be repeated, if needed up to 25 times, until the Operate mode is actually set. If this condition persists, contact Amplifier Research Service for additional assistance. (See *Explanation of....*, below)

Noise Power Density (NPD): TWTAs produce RF noise over their operating frequency range, as specified by the Noise Power Density (NPD). This noise is significantly higher than the noise produced by typical solid state amplifiers, and is inherent in present TWTAs. The noise may surprise users new to TWTAs when it accumulates and results in a significant indication in a broadband measurement device – such as a power meter or field probe. The error produced by this indication is not significant when operating near rated TWTA power levels, but may cause difficulty when trying to operate high power TWTAs at low output power levels..

For example, consider a hypothetical typical NPD of -76 dBm/Hz, from a 4 GHz bandwidth amplifier. A broadband detector might see the NPD as $[-76 \text{ dBm/Hz} + 10 (\log 4 \times 10^9) \text{ BW factor} = -76 + 96 =] +20$ dBm, or 0.1 watts. This power is insignificant for a user operating at 200 watts (+53 dBm), but may be very noticeable to a user trying to operate below 1 watt (+30 dBm). [One watt is 0.5% of (23dB below) rated power for a 200 watt amplifier.] A field probe user who obtains a 200 V/M field with 200 watts, may see a field as high as $[53\text{dBm} - 20\text{dBm} = 33\text{dB below } 200 \text{ V/M} =] 4.5 \text{ V/M}$ due to this hypothetical NPD.

For these applications the use of a lower power amplifier is highly recommended, especially when considering safety issues. Alternatively, additional power loss in the form of an added high power microwave attenuator, or preferably an increased space loss for radiated fields, may be used to lower the noise received by the broadband measurement device.

Explanation of Limiting the Time in Standby mode and of Repeated Operate Selection

Traveling wave tubes tend to get “gassy” if they are left in a Standby mode for extended periods of time. In this Standby mode, the heater (filament) is on but there is no high voltage applied to the collector (or high voltage is applied to the collector but the grid is off). This is the normal state after a tube’s warm up time, just prior to entering the Operate mode.

In this state the cathode end of the TWT is heating up but the electron “Beam” is off. In other words, there is no cathode current. As the cathode heats up, gas trapped in the structure of the tube can be released, thus corrupting the vacuum of the tube. If the tube become too “gassy”, arcing may occur when the high voltage is fully applied in the Operate mode. Another possible failure mode is a body over-current fault when the beam is turned on and the tube is “gassy”.

Occasional arcing is normal for a TWT. The support components are designed to handle this, protecting both the TWT and its support circuitry. However, if the tube arcs two or three times in rapid succession, or worse yet repeatedly, a fault will be sensed that will shut the high voltage off, thus removing the unit from Operate status. The remedy usually recommended is to repeat the selection of the Operate mode until the unit remains in Operate. It has been found that most of the faults that can be cleared by this method will be cleared within 25 attempts to enter the Operate mode.

Once the tube is operating normally, gas will continue to evolve at a slow enough rate that the TWTA will not fault. This happens because the gas in the tube will interact with the beam and become ionized. As the electrons in the beam hit the gas molecules they ionize the gas, at which point it is accelerated into the collector structure and “buried” deep enough so that it ceases to be a problem.

To preclude this gassing problem, and thus reduce the need for repeating the Operate selection, it is recommended that the time in Standby be limited – to about one hour. Extended periods in Standby may result in an inability to clear the fault by this method. In this case, service measures may be needed to correct the unit. Thus, users should reduce the likelihood of occurrence of this problem by limiting the amount of time in the Standby mode.

The service measures involve pulsing of the tube beam current and gradually increasing the duty of the pulsing until the unit will operate continuously. Note that a similar condition can exist for tubes with grids when the TWTA is in the Operate mode (high voltage is on) but gating (control) input is set so that the grid turns off the TWT beam current. Operational procedures should also limit the time in this mode.

4. MAINTENANCE

The TWTA requires a minimum of routine maintenance. The only moving parts are the elements of switches, relays and blowers. Preventive maintenance is recommended in Section 4.3.

In the event that the TWTA needs repairs, it is recommended that the unit be returned to the factory. However, some user service organizations may choose to perform their own corrective maintenance, and under some circumstances returning the unit to the factory may be impractical. The highly modular construction of the TWTA facilitates troubleshooting to the level of readily replaced subassemblies. Section 5 provides partial technical documentation to support field repairs. Nevertheless, the factory or its service representative should be contacted before undertaking repair work on these TWTAs. **Warnings and Cautions must be observed.**

4.1 SAFETY WARNING



WARNING:

Service work must be performed only by technicians thoroughly familiar with the high voltages present in microwave tube amplifiers in general, and with this equipment in particular.

Never handle the TWT leads or the high-voltage connectors unless it has been positively established that the high-voltage filter capacitors have been discharged to a *known* safe level.



CAUTION:

A malfunctioning power supply can cause damage to the TWT. If you are troubleshooting the TWTA, remove the TWT and substitute suitable loads to prevent damage to the TWT.

4.2 UNAUTHORIZED REPAIRS



CAUTION:

Unauthorized repairs or modification of this product during the warranty period may void the warranty. In the event that the TWTA malfunctions while it is still under warranty, always contact an authorized service representative.

4.3 PREVENTIVE MAINTENANCE

The RF characteristics, power supply voltages and currents, and system temperatures of the TWTA should be logged on a regular basis. Maintenance should be performed if significant deviations from the logged values appear. For a unit still under warranty, contact an authorized service representative if impaired performance is suspected.

The air intake filters are the only items that require routine service. The frequency of service depends on the environment where the TWTA is used, and must be determined by inspection.

If there is accumulated dust on any of the air intake filters, remove them and clean them with dry compressed air. If the filters show signs of deterioration, purchase replacement units.

If significant dust has been noted on the air intake filters, it may be desirable to vacuum the dust and debris from inside the enclosure. Perform this procedure to only one power supply at a time:

1. Remove the power supply subassembly from the rack as follows:

NOTE: Due to the weight in excess of fifty pounds, the removal of some of the amplifier's units from the cabinet is a two person operation.

Disconnect power. Remove any other cables. On the front of the unit, remove the four screws (two outside screws on each side) mounting the front panel to the cabinet. Carefully slide the unit out of the front of the cabinet. Depress the buttons on each slide rail to remove the unit from the rack

2. Remove the screws that secure the upper and lower covers. Remove the covers to gain access to the interior of the unit.
3. Vacuum dust and debris from inside the enclosure. Clean dust from the power supply high voltage leads. Remove any dirt from around the high voltage connectors. While the cover is off, check for loose wires, components or fasteners.
4. Reassemble in reverse order. Reconnect rear panel cables.

CAUTION:



Be especially careful with type SMA RF connectors, which are fragile and easily damaged when incorrectly aligned during the assembly process.

4.4 TROUBLESHOOTING

Symptom	Possible cause
TWT or power supply overtemperature	Air inlet filter(s) dirty Collector heat sink dirty Inadequate clearance behind TWTA High air inlet temperature Defective fan or fan driver
No response when main power turned on	Disconnected power cable Defective circuit breaker
Control module display does not come up; unit does not beep when powered up	Shorted or defective control module power supply
Control module does not boot	EPROM(s) missing Control head PC board defective
Control module "datalink failure" error appears	HPA interface failure. Data steering board failure Fiberoptic link failure ± 15 VDC supply failure
Heater power supply does not come up	Defective low voltage power supply module Defective heater power supply module
No high voltage	Keylock switch on INHIBIT or REMOTE Defective high voltage power supply.
Voltages normal, but no RF output, helix current low	No RF input Defective SSA Gain turned down

After review of the symptoms of the failure, the user may want to check for a loose connector or component especially after rough handling of the unit. Look externally for physical damage or loose connectors and internally for unmated or loose parts.

The service technician should become familiar with the internal mechanical construction to permit correct reassembly. Limited troubleshooting may be conducted, with caution, based on the failure symptom and an understanding of the logic/schematic diagrams.

4.5 NON-REPAIRABLE MODULES

The following modules are encapsulated and not repairable. Contact an authorized service representative if replacement modules are needed.

A27824-100	Heater Power Supply Module
A30594-001	Grid Modulator Assembly
A33176-001	High Voltage Filter Assembly
A33185-000	High Voltage Diode/Cap Assembly
A33090-001	Capacitor Bank

4.6 RECOMMENDED SPARE PARTS

A27824-100	Heater Power Supply Module
A30467-000	Power Inverter
A30594-001	Grid Modulator Assembly
A33176-001	High Voltage Filter Assembly
A33185-000	High Voltage Diode/Cap Assembly
A23683-003	Power Factor Correction Module
A26452-150	Low Voltage Power Supply Module
E02822-000	SSPA, C-Band, 4.0-8.0 GHz
E01120-000	Fan 11000 RPM, 400Hz

5. TECHNICAL DOCUMENTATION

NOTE: The purpose of this technical documentation section is to provide a guide to the TWTA for technician-level servicing. It is intended for use by qualified technical personnel who must troubleshoot and repair the TWTA in the field. Such repairs are typically limited to replacement of modules or major components. For this reason, only documentation pertaining to the highest levels of the system and to system control logic is included.

5.1 SCHEMATICS

10-23050-085	HPA Logic and Control (A23050-085)
10-25444-001	HPA Interface (A25444-001)
10-25450-000	CPU Board (A25450-000)
10-38006-100	43PKu Pulsed HPA

5.2 PARTS LISTS

A23050-084	HPA Logic and Control Assembly
A25444-001	HPA Interface Board

5.3 TOP LEVEL BUILD TREE

A38006-400	43PC Pulsed HPA
------------	-----------------

5.4 SAMPLE PROGRAM FOR IEEE-488 COMMUNICATION

```
1000 ! *****
1010 ! *      IEEE-488 COMMUNICATIONS SOFTWARE      *
1030 ! *      7/24/92  AARON D. McCLURE          *
1040 ! *****
1041 DIM F$(80)
1042 DIM A$(80)
1050 CLEAR SCREEN
1060 INPUT "INPUT COMMAND TO SEND TO POWER SUPPLY.  EXIT TO QUIT. ",A$
1070 IF A$="EXIT" THEN 1130
1080 OUTPUT 701;A$
1090 IF A$[1,2]<>"RD" THEN GOTO 1060
1095 IF A$[1,1]="*" THEN GOTO 1100
1100 ENTER 701;F$
1110 PRINT "OUTPUT FROM COMMAND ",A$," IS ",F$
1120 GOTO 1060
1130 CLEAR SCREEN
1140 END
```

WARRANTIES: LIMITATION OF LIABILITY

Seller warrants (i) that seller has title to the goods sold and (ii) that Amplifiers (all parts excluding traveling wave and vacuum tubes), Antennas, field monitors, field probes, field analyzers, field analyzer processor units, system controllers, system interlock, power meters, leak detectors, RF conducted probes, RF conducted clamps, Multi-tone, EMI receiver systems, RF down converters, RF conducted immunity systems, conducted immunity accessories, radiated immunity test systems, safety meters, safety sensor heads, tripods, directional couplers, waveguide adapters, termination loads, load attenuators, impedance stabilization networks, and coaxial cables will be free from defects in material and workmanship for a period of three (3) years from date of shipment shown on AR RF/Microwave Instrumentation invoice.

All modules, used in the amplifiers for the 1-6 GHz, 4-18 GHz, 6-18 GHz, all HPM products, and other applications, are hermetically-sealed. This sealing process protects the internal hybrid circuitry from humidity that could compromise the long term reliability of the product. These modules are not field-repairable and should *never* be opened outside of AR's Microelectronics Lab. The modules in these product lines have a security label on two sides of the modules between the housing and lid/cover. If the security label is removed and or cut, the warranty of the module will be voided.

Vacuum tubes in the 'L' series amplifiers, traveling-wave tubes in TWT amplifiers, and power heads will be free from defects in material and workmanship for a period of one (1) year.

Contact AR RF/Microwave Instrumentation for warranty information regarding items not listed.

Seller's sole responsibility in fulfilling these warranties shall be to repair or replace any goods which do not conform to the foregoing warranties or, at seller's option, to give buyer credit for defective goods. The warranty is valid only when used in the country specified at time of order. Warranty service must be obtained from the repair facility designated at that time. If warranty service is not available in the country where the equipment is to be used, it must be returned to AR RF/Microwave Instrumentation. Warranty service will be provided only for defective goods which are returned within the warranty period, freight costs prepaid to AR RF/Microwave Instrumentation or its designated repair facility.

There are no other warranties, express or implied, including any warranty of merchantability or fitness. Seller shall not be responsible for any incidental or consequential damages arising from any breach of warranty.

No person other than an officer of Amplifier Research Corporation, has any authority to bind seller to any affirmation, representation or warranty except as specifically included in the preceding terms and conditions.

