



Operating and Service Manual

350AH1A

Model

10042958

Part Number

Serial Number



rf/microwave instrumentation

Declaration of Conformity

Issue Date: December 2018
Model #/s: 350AH1A Series
Type of Equipment: RF broadband amplifier
Function: Designed to be used in a RF immunity test system or for research. The unit is intended to amplify an RF signal and inject it into a load.

The equipment described above is declared to be in conformity with the following applicable national and international standards. The conformity is valid only when equipment is used in a manner consistent with the manufacturer's recommendations and the reference documents.

EMC:
DIRECTIVE 2014/30/EU OF THE EUROPEAN PARLIAMENT AND OF THE COUNCIL of 26 February 2014 on the harmonisation of the laws of the Member States relating to electromagnetic compatibility
EN 61326-1:2013 Electrical equipment for measurement, control and laboratory use–EMC requirements–Part 1: General Requirements
SAFETY:
DIRECTIVE 2014/35/EU OF THE EUROPEAN PARLIAMENT AND OF THE COUNCIL of 26 February 2014 on the harmonisation of the laws of the Member States relating to the making available on the market of electrical equipment designed for use within certain voltage limits
CENELEC EN 61010-1 Issued 2010/10/01 Ed: 3 Safety Requirements for Electrical Equipment for Measurement Control and Laboratory Use – Part 1: General Requirements
UL 61010-1 Issued 2012/05/11 Ed: 3 Safety Requirements for Electrical Equipment for Measurement Control and Laboratory Use – Part 1: General Requirements
CAN/CSA C22.2 #61010-1 Issued 2012/05/11 Ed: 3 Safety Requirements for Electrical Equipment for Measurement Control and Laboratory Use – Part 1: General Requirements
HAZARDOUS SUBSTANCES (RoHS 3):
DIRECTIVE (EU) 2017/2105 OF THE EUROPEAN PARLIAMENT AND OF THE COUNCIL of 15 November 2017 on the restriction of the use of certain hazardous substances in electrical and electronic equipment (recast)
RECYCLING (WEEE):
DIRECTIVE 2012/19/EU OF THE EUROPEAN PARLIAMENT AND OF THE COUNCIL of 4 July 2012 on waste electrical and electronic equipment (WEEE) (recast)
SUBSTANCES OF VERY HIGH CONCERN (REACH):
REGULATION (EC) 1907/2006 OF THE EUROPEAN PARLIAMENT AND OF THE COUNCIL of 18 December 2006 concerning the Registration, Evaluation, Authorization and Restriction of Substances of Very High Concern Chemicals (SVHC)

Supporting documentation is held by AR RF/Microwave Instrumentation's Quality department in Pennsylvania, United States.

Place of issue: AR RF/Microwave Instrumentation
 160 School House Road
 Souderton, Pennsylvania 18964 USA

Authorized officer of the company:

Patricia Thrasher
 Manager Quality, Customer Service, Purchasing

INSTRUCTIONS FOR SAFE OPERATION









Observe the following safety guidelines to help ensure your own personal safety and to help protect your equipment and working environment from potential damage.

INTENDED USE

This equipment is intended for general laboratory use in generating, controlling, and measuring levels of electromagnetic Radio Frequency (RF) energy. Ensure that the device is operated in a location which will control the radiated energy and will not cause injury or violate regulatory levels of electromagnetic interference.

SAFETY SYMBOLS

These symbols may appear in your user manual or on equipment.

	This symbol is marked on the equipment when it is necessary for the user to refer to the manual for important safety information. The caution symbol denotes a potential hazard. Attention must be given to the statement to prevent damage, destruction, or harm.
	Dangerous voltages are present. Use extreme care.
	Indicates a terminal intended for connection to an external conductor for protection against electrical shock in case of a fault, or the terminal of a protective earth (ground) electrode.
	Indicates invisible laser radiation—do not view directly with optical instruments.
	Indicates frame or chassis ground connection terminal.
	Indicates alternating current.
	Indicates this product must not be disposed of with your other household waste.
	Indicates that the marked surface and adjacent surfaces can attain temperatures that may be hot to the touch.

EQUIPMENT SETUP PRECAUTIONS



Review the user manual and become familiar with all safety markings and instructions. Protection provided by the equipment may be impaired if used in a manner not specified by AR RF/Microwave Instrumentation (AR).

- Follow all lifting instructions specified in this document.
- Place the equipment on a hard, level surface.
- Do not use the equipment in a wet environment, for example, near a sink, or in a wet basement.
- Position your equipment so that the power switch is easily accessible.
- Leave 10.2 cm (4 in) minimum of clearance on all vented sides of the equipment to permit the airflow required for proper ventilation. Do not restrict airflow into the equipment by blocking

any vents or air intakes. Restricting airflow can result in damage to the equipment, intermittent shut-downs or safety hazards.

- Keep equipment away from extremely hot or cold temperatures to ensure that it is used within the specified operating range.
- While installing accessories such as antennas, directional couplers and field probes, take care to avoid any exposure to hazardous RF levels.
- Ensure that nothing rests on your equipment's cables and that the cables are not located where they can be stepped on or tripped over.
- Move equipment with care; ensure that all casters and/or cables are firmly connected to the system. Avoid sudden stops and uneven surfaces.

BEFORE APPLYING POWER

Your AR equipment may have more than one power supply cable. Use only approved power cable(s). If you have not been provided with a power cable for the equipment or for any AC-powered option intended for the equipment, purchase a power cable that is approved for use in your country. The power cable must be rated for the equipment and for the voltage and current marked on the equipment's electrical ratings label.



Incorrectly installing or using an incompatible line voltage may increase the risk of fire or other hazards. To help prevent electric shock, plug the equipment and peripheral power cables into properly grounded electrical outlets. These cables are equipped with three-prong plugs to help ensure proper grounding. Do not use adapter plugs or remove the grounding prong from a cable.

Do not modify power cables or plugs. Consult a licensed electrician or AR trained service technician for equipment modifications. Always follow your local/national wiring rules.



Do not operate the equipment if there is physical damage, missing hardware, or missing panels.

SAFETY GROUND



This equipment is provided with a protective earth terminal. The mains power source to the equipment must supply an uninterrupted safety ground of sufficient size to attach wiring terminals, power cord, or supplied power cord set. ***DO NOT USE this equipment if this protection is impaired.***

INSTRUCTIONS FOR SAFE OPERATION

HAZARDOUS RF VOLTAGES



The RF voltages on the center pin of an RF output connector can be hazardous. The RF output connector should be connected to a load before AC power is applied to the equipment. Do not come into contact with the center pin of the RF output connector or accessories connected to it. Place the equipment in a non-operating condition before disconnecting or connecting the load to the RF output connector.

ACOUSTIC LIMITATIONS

If equipment noise exceeds 80dB, ear protection is required.

MAINTENANCE CAUTION

Adjustment, maintenance, or repair of the equipment must be performed only by qualified personnel. Hazardous energy may be present while protective covers are removed from the equipment even if disconnected from the power source. Contact may result in personal injury. Replacement fuses are required to be of specific type and current rating.

ENVIRONMENTAL CONDITIONS

Unless otherwise stated on the product specification sheet, this equipment is designed to be safe under the following environmental conditions:

- Indoor use
- Altitude up to 2000m
- Temperature of 5°C to 40°C
- Maximum relative humidity 80% for temperatures up to 31°C. Decreasing linearly to 50% at 40°C.
- Main supply voltage fluctuations not to exceed $\pm 10\%$ of the nominal voltage or minimum and maximum autoranging values.
- Pollution degree 2: Normally non-conductive with occasional condensation. While the equipment will not cause hazardous condition over this environmental range, its performance may vary.

EQUIPMENT CONTAINING LASERS



AR Field Probes (FL/PL Series) and Field Analyzers (FA Series) are Class 1 laser products containing embedded Class 4 lasers. Under normal use, the laser radiation is completely contained within the fiber optic cables and poses no threat of exposure. Safety interlocks ensure that the laser is not activated unless the cables are properly connected. Always exercise caution when using or maintaining laser products. Do not view directly with optical instruments.

RF ANTENNAS

- This equipment (antenna or antenna assembly) may be heavy, requiring two persons to lift. Use caution when installing or removing unit. Follow all equipment setup and lifting instructions specified in this document.
- Ensure connectors are appropriate for intended operation. Connectors are specified in the user manual and product specification sheet.
- Do not exceed the maximum RF input level stated in the specifications. Refer to the user manual and product specification sheet to determine the applicable RF levels.
- Excessive RF input could damage the equipment or connectors, causing safety hazards.
- When in operation, the RF voltages on the antenna elements can be hazardous. Do not come into contact with the antenna or elements when the RF input connector is connected to a live RF source.
- To avoid injury to personnel and accidental damage to power amplifier or antenna, disable the RF output of power amplifier before connecting or disconnecting the input connection to the antenna.
- Perform periodic inspections of antenna and field probe systems to verify calibration due date, proper operation, and overall condition of equipment.

RACK MOUNTED TWT MODELS

Some TWT models are supplied without the removable enclosure offered for benchtop use. These rack-mountable models may be supplied with either carry handles or slides and front handles installed. Follow all lifting instructions specified in this document and installation instructions supplied in the TWT user manual.

LIFTING INSTRUCTIONS FOR AR EQUIPMENT

Because most products must be handled during distribution, assembly and use, the risk of serious injury due to unsafe product handling should be a fundamental consideration of every user. An authoritative guideline for eliminating unwarranted risk of injury caused by lifting is provided by the NIOSH Work Practices (Publication #94-110) available at:



<https://www.cdc.gov/niosh/docs/94-110/pdfs/94-110.pdf>.

In general, observe the following guidelines for lifting a weight of 50 lb or more:

- Use lifting eye (for floor standing) or side handles (table top) to lift unit only.
- Use equipment of adequate capacity to lift and support unit.
- If using forklift to move unit, be sure forks are long enough to extend beyond the side of the unit.
- For additional information, follow the link specified above.

HINWEISE FÜR DEN SICHEREN GEBRAUCH









Bitte beachten Sie die folgenden Hinweise zum Schutz Ihrer persönlichen Sicherheit und um Ihre Ausrüstung und Ihren Arbeitsplatz vor möglichen Schäden zu bewahren.

VORGESEHENE VERWENDUNG

Dieses Gerät ist für den allgemeinen Einsatz im Labor bestimmt. Es dient der Erzeugung, Steuerung und Messung von elektromagnetischer Hochfrequenzenergie (RF). Stellen Sie sicher, dass das Gerät an einem Ort in Betrieb genommen wird, an dem die abgestrahlte Energie gesteuert werden kann, so dass niemand Schaden erfährt und elektromagnetische Störungen vermieden werden.

SICHERHEITSSYMBOL

Einige dieser Symbole befinden sich sowohl in der Bedienungsanleitung als auch auf dem Gerät selbst.

	Dieses Symbol befindet sich auf dem Gerät und weist darauf hin, dass der Nutzer an dieser Stelle wichtige Sicherheitsinformationen in der Bedienungsanleitung studieren soll. Das Warnsymbol weist auf eine mögliche Gefahr hin. Zur Vermeidung von Personen- oder Sachschäden gilt es, die Hinweise zu beachten.
	Gefährliche elektrische Spannungen sind vorhanden. Höchste Vorsicht ist geboten.
	Weist darauf hin, dass an dieser Stelle eine Klemme für den Anschluss an einen Außenleiter anzubringen ist, zum Schutz vor einem Stromschlag oder im Fall einer auftretenden Störung, oder dass eine Klemme anzubringen ist, die als schützende Erdungselektrode fungiert.
	Zeigt unsichtbare Laserstrahlung an – nicht direkt hineinschauen.
	Weist auf eine Rahmen- oder Chassis-Anschlussklemme hin.
	Zeigt Wechselstrom an.
	Weist darauf hin, dass dieses Produkt nicht mit Ihrem restlichen Hausmüll entsorgt werden darf.
	Weist darauf hin, dass die markierte Oberfläche und benachbarte Flächen extrem heiße Temperaturen erreichen können und daher nicht angefasst werden sollten.

SICHERHEITSHINWEISE FÜR DEN AUFBAU DES GERÄTS



Lesen Sie die Bedienungsanleitung aufmerksam durch und machen Sie sich mit allen Sicherheitsmarkierungen und Anweisungen vertraut. Die Sicherheit kann beeinträchtigt sein, falls das Gerät in einer anderen Weise verwendet wird, als von der AR RF/Microwave Instrumentation (AR) vorgegeben ist.

- Zum Heben und Transport folgen Sie allen in dieser Anleitung angegebenen Anweisungen.
- Platzieren Sie das Gerät auf einer harten, ebenen Oberfläche.
- Verwenden Sie das Gerät nicht in feuchter Umgebung, zum Beispiel in der Nähe einer Spüle oder in einem feuchten Keller.
- Platzieren Sie Ihr Gerät so, dass der Netzschalter leicht zugänglich ist.

- Halten Sie einen Mindestabstand von 10,2 cm (4 in) auf allen belüfteten Seiten des Geräts ein, um eine ausreichende Luftzirkulation zu gewährleisten. Beeinträchtigen Sie den Luftstrom des Geräts nicht, indem Sie Lüftungsöffnungen oder den Lufteinlass blockieren. Wird der Luftstrom eingeschränkt, kann dies zu Schäden am Gerät, periodischen Abschaltungen und anderen Gefahren führen.
- Halten Sie das Gerät von extrem heißen oder kalten Temperaturen fern, um sicherzustellen, dass es nur in dem vorgeschriebenen Bedienungsbereich verwendet wird.
- Achten Sie beim Installieren von Zubehör wie Antennen, Richtungskupplungen und Feldsonden darauf, dass sie keinen gefährlichen HF-Werten ausgesetzt sind.
- Stellen Sie sicher, dass nichts auf den Kabeln Ihres Geräts steht. Bringen Sie die Kabel so an, dass niemand darauf treten oder darüber stolpern kann.
- Seien Sie vorsichtig, wenn Sie das Gerät bewegen. Achten Sie darauf, dass alle Rollen und/oder Kabel fest mit dem System verbunden sind. Vermeiden Sie plötzliche Stopps und Oberflächen, die nicht eben sind.

BEVOR SIE DAS GERÄT ANSCHLIESSEN

Ihre AR-Ausrüstung hat möglicherweise mehr als ein Stromversorgungskabel. Verwenden Sie nur zugelassene Stromkabel. Falls Sie kein Stromkabel oder AC-Netzkabel für dieses Gerät haben, kaufen Sie ein Stromkabel, das für den Einsatz in Ihrem Land zugelassen ist. Das Stromkabel muss für das Gerät, die Spannung und den Strom, die auf dem elektrischen Kennzeichnungsetikett des Geräts markiert sind, zugelassen sein.



Bei einer fehlerhaften Installation oder falls eine Netzspannung verwendet wird, die nicht mit dem Gerät kompatibel ist, erhöht sich die Brandgefahr. Auch andere Gefahren können auftreten. Um einen Stromschlag zu verhindern, schließen Sie das Gerät und die peripheren Stromkabel an ordnungsgemäß geerdete Steckdosen an. Die Kabel sind mit dreipoligen Steckern ausgestattet, um eine korrekte Erdung zu gewährleisten. Verwenden Sie keine Adapter. Entfernen Sie niemals die Erdungsstange eines Kabels.

Modifizieren Sie niemals die Stromkabel oder Stecker. Konsultieren Sie einen lizenzierten Elektriker oder AR-ausgebildeten Servicetechniker, falls Veränderungen am Gerät durchgeführt werden müssen. Halten Sie sich stets an die nationalen/örtlichen Verdrahtungsregeln.



Schalten Sie das Gerät nicht ein, falls es äußerlich beschädigt ist oder Hardware-Teile oder Konsolen fehlen.

SYSTEMERDUNG



Dieses Gerät ist mit einer Schutzerdklemme ausgestattet. Die Netzstromquelle muss dem Gerät eine ununterbrochene Systemerdung von ausreichender Größe zur Verfügung stellen, damit Kabelklemmen, Netzkabel oder mitgeliefertes Netzkabel ordentlich befestigt werden können. **VERWENDEN SIE DIESES GERÄT NICHT, wenn dieser Schutz beeinträchtigt ist.**

HINWEISE FÜR DEN SICHEREN GEBRAUCH

GEFÄHRLICHE HF-SPANNUNGEN



Die HF-Spannungen am mittleren Pin eines HF-Ausgangsanschlusses können gefährlich sein. Der HF-Ausgangsanschluss sollte an eine Last angeschlossen werden, bevor das Gerät ans Stromnetz angeschlossen wird. Kommen Sie nicht mit dem Mittelstift des HF-Ausgangsanschlusses oder dem damit verbundenen Zubehör in Kontakt. Bevor Sie die Last vom HF-Ausgang trennen oder diese anschließen, stellen Sie das Gerät in einen nicht betriebsfähigen Zustand.

HÖRSCHUTZ

Sollten die Geräusche, die das Gerät verursacht, 80dB überschreiten, ist Gehörschutz erforderlich.

WARTUNGSHINWEISE

Einstellung, Wartung oder Reparaturen der Ausrüstung dürfen nur von qualifizierten Fachleuten durchgeführt werden. Gefährliche Spannungen können auftreten, wenn Schutzabdeckungen vom Gerät entfernt werden, auch wenn es nicht an die Stromquelle angeschlossen ist. Kontakt kann zu Verletzungen führen. Es können nur bestimmte Ersatzsicherungen mit speziellem Nennstrom verwendet werden.

UMGEBUNGSBEDINGUNGEN

Sofern auf dem Produktspezifikations-Blatt nichts anderes angegeben ist, ist dieses Gerät unter folgenden Bedingungen sicher einsetzbar:

- Gebrauch in Innenräumen
- Höhe bis zu 2000m
- Temperaturen von 5°C bis 40°C
- Maximale relative Luftfeuchtigkeit 80% bei Temperaturen bis 31°C. Lineare Abnahme auf 50% bei 40°C.
- Netzspannungsschwankungen sollen nicht mehr als $\pm 10\%$ der Nennspannung oder der minimal und maximal eingestellten Werte betragen.
- Verschmutzungsgrad 2: Normalerweise nichtleitfähige Verschmutzung mit gelegentlicher Kondensation. Das Gerät wird bei Einsatz in diesem Bereich keine Gefahr verursachen, die Leistung kann dennoch variieren.

LASER-INFORMATION



AR - Feldsonden (FL/PL-Serie) und Feldanalysatoren (FA-Serie) sind Laserprodukte der Klasse 1 mit eingebetteten Klasse-4-Lasern. Bei normalem Gebrauch kann der Laserstrahlung nicht aus den Glasfaserkabel herausdringen. Sicherheitsverriegelungen sorgen dafür, dass der Laser nur aktiviert wird, wenn die Kabel richtig angeschlossen sind. Lassen Sie stets Vorsicht walten bei der Verwendung oder Wartung von Laserprodukten. Niemals direkt hineinschauen.

HF-ANTENNEN

- Die Ausrüstung (Antenne oder Antennenmontage) ist mitunter schwer. Die Montage erfordert daher oft zwei Personen. Folgen Sie allen in diesem Dokument angegebenen Anweisungen zur Anbringung.
- Stellen Sie sicher, dass alle Anschlüsse für den beabsichtigten Betrieb geeignet sind. Informationen zu den Anschlüssen erhalten Sie im Benutzerhandbuch und im Produktspezifikationsblatt.
- Überschreiten Sie nicht den in Spezifikationen angegebenen maximalen HF-Eingangspegel. Informationen zum geeigneten HF-Pegel erhalten Sie im Benutzerhandbuch und im Produktspezifikationsblatt.
- Ein übermäßiger HF-Eingang könnte das Gerät oder die Anschlüsse beschädigen, was zu Sicherheitsrisiken führt.
- Im Betrieb können die HF-Spannungen an den Antennenelementen gefährlich sein. Kommen Sie nicht mit der Antenne oder Antennenelementen in Kontakt, wenn der HF-Eingang an eine live-HF-Quelle angeschlossen ist.
- Um Verletzungen an Personen, am Leistungsverstärker oder der Antenne zu vermeiden, deaktivieren Sie den HF-Ausgang des Leistungsverstärkers, bevor sie die Eingangsverbindung an die Antenne anschließen oder trennen.
- Kontrollieren Sie die Antennen und die Feldsonde regelmäßig, um die nächstfällige Kalibrierung, den ordnungsgemäßen Betrieb und den Gesamtzustand der Ausrüstung zu überprüfen.

RACK MONTIERBARE TWT-MODELLE

Einige TWT-Modelle kommen ohne die abnehmbare Überdachung, die zur Verwendung als Tischgerät dient. Diese rack-montierbaren Modelle verfügen entweder über installierte Tragegriffe oder Rutschflächen. Befolgen Sie alle in diesem Dokument angegebenen Hebehinweise sowie die Installationsanweisungen in der TWT-Bedienungsanleitung.

HEBEANWEISUNGEN FÜR AR-GERÄTE

Die meisten Geräte müssen während des Versands, der Montage und des Gebrauchs transportiert werden. Jeder Nutzer sollte sich über das Risiko von schweren Verletzungen durch unsachgemäße Produkthandhabung bewusst sein. Leitlinien zur Beseitigung von vermeidbaren Verletzungsrisikos, die beim Heben entstehen können, werden in den NIOSH-Arbeitspraktiken (Veröffentlichung # 94-110) zur Verfügung gestellt:



<https://www.cdc.gov/niosh/docs/94-110/pdfs/94-110.pdf>.

Beachten folgende, allgemeine Richtlinien zum Heben eines Gewichts von 50 Pfund oder mehr:

- Verwenden Sie zum Heben der Einheit eine Hebeöse (für Platzierung auf dem Boden) oder Seitengriffe (für Platzierung auf einer Arbeitsplatte).
- Verwenden Sie Geräte mit ausreichender Kapazität zum Heben und Stützen.
- Falls Sie einen Gabelstapler verwenden, achten Sie darauf, dass die Gabeln lange genug sind und über die Seiten der Einheit hinausreichen.
- Für weitere Informationen folgen Sie dem oben angegebenen Link.

INSTRUCTIONS POUR UN FONCTIONNEMENT EN TOUTE SÉCURITÉ









Respectez les consignes de sécurité suivantes pour veiller à votre propre sécurité et vous aider à protéger votre équipement et votre milieu de travail de dommages potentiels.

USAGE PRÉVU

Cet équipement est prévu pour un usage général en laboratoire afin de générer, contrôler et mesurer les niveaux d'énergie de radiofréquence (RF) électromagnétique. Assurez-vous que l'appareil est utilisé dans un endroit qui contrôlera l'énergie rayonnante et ne causera pas de blessure, ni ne violera les niveaux réglementaires d'interférence électromagnétique.

SYMBOLES DE SÉCURITÉ

Ces symboles peuvent apparaître dans votre manuel d'utilisation ou sur l'équipement.

	Ce symbole est apposé sur l'équipement lorsque l'utilisateur doit se référer au manuel pour des informations importantes concernant la sécurité. Le symbole de mise en garde indique un danger potentiel. Vous devez accorder une attention à la déclaration pour éviter tout dommage, destruction ou blessure.
	Présence de tensions dangereuses, soyez très prudent.
	Indique une borne de connexion d'un conducteur externe pour une protection contre l'électrocution en cas de défaillance ou la borne d'une électrode de mise à la terre de protection.
	Indique un rayonnement laser invisible – ne regardez pas directement avec des instruments optiques.
	Indique la borne de connexion de la mise à la terre du cadre ou du châssis.
	Indique un courant alternatif.
	Indique que ce produit ne doit pas être jeté avec vos autres déchets ménagers.
	Indique que la surface marquée et les surfaces adjacentes peuvent atteindre des températures qui risquent d'être chaudes au toucher.

PRÉCAUTIONS D'INSTALLATION DE L'ÉQUIPEMENT

 Lisez le manuel d'utilisateur et familiarisez-vous avec tous les marquages et consignes de sécurité. La protection fournie par l'équipement peut être affaiblie s'il est utilisé d'une manière non indiquée par AR RF/instrumentation à hyperfréquence (AR).

- Respectez toutes les instructions de levage indiquées dans ce document.
- Placez l'équipement sur une surface dure et plane.

- N'utilisez pas l'équipement dans un environnement humide, par exemple près d'un lavabo, ou dans un sous-sol humide.
- Positionnez votre équipement de sorte que l'interrupteur d'alimentation soit facilement accessible.
- Laissez un espace minimal de 10,2 cm (4 in) de tous les côtés ventilés de l'équipement pour permettre le flux d'air nécessaire à une bonne ventilation. Ne limitez pas le flux d'air allant dans l'équipement en bloquant tout évent ou entrée d'air. La restriction du flux d'air peut endommager l'équipement, causer des coupures intermittentes ou des dangers pour la sécurité.
- Tenez l'équipement à l'écart de températures extrêmement chaudes ou froides pour veiller à ce qu'il soit utilisé dans la plage de fonctionnement indiquée.
- Lorsque vous installez des accessoires tels que des antennes, des coupleurs directionnels et des sondes de champ, prenez soin d'éviter toute exposition à des niveaux RF dangereux.
- Assurez-vous que rien n'est posé sur les câbles de votre équipement et que les câbles ne se trouvent pas à des endroits où l'on peut marcher dessus ou trébucher.
- Déplacez l'équipement avec soin ; veillez à ce que tous les câbles et/ou roulettes soient solidement raccordés au système. Évitez les arrêts brusques et les surfaces irrégulières.

AVANT LA MISE SOUS TENSION

Votre équipement AR peut disposer de plus d'un câble d'alimentation électrique. Utilisez uniquement un ou des câbles d'alimentation approuvés. Si un câble d'alimentation ne vous a pas été fourni avec l'équipement ou pour toute option alimentée en courant alternatif prévue pour l'équipement, achetez un câble d'alimentation qui est approuvé pour être utilisé dans votre pays. Le câble d'alimentation doit être prévu pour l'équipement et pour le courant et la tension indiqués sur l'étiquette de classement électrique de l'équipement.



Installer ou utiliser de façon incorrecte une tension de ligne incompatible peut augmenter le risque d'incendie ou d'autres dangers. Pour aider à éviter toute électrocution, branchez l'équipement et les câbles d'alimentation périphériques dans des prises électriques correctement mises à la terre. Ces câbles sont équipés de prises à trois broches pour veiller à une bonne mise à la terre. N'utilisez pas d'adaptateur de prise, ni ne retirez la broche de mise à la terre d'un câble.

Ne modifiez pas les câbles ou les prises d'alimentation. Consultez un électricien agréé ou un technicien d'entretien AR qualifié pour les modifications d'équipement. Respectez toujours les règles locales/nationales de câblage.



N'utilisez pas l'équipement s'il est physiquement endommagé ou s'il manque des pièces ou des panneaux.

MISE À LA TERRE DE SÉCURITÉ



Cet équipement est fourni avec une borne de mise à la terre de protection. La source d'alimentation secteur à l'équipement doit fournir une mise à la terre de sécurité ininterrompue de taille suffisante pour attacher les bornes de câblage, le cordon d'alimentation ou l'ensemble de câbles d'alimentation fourni. **N'UTILISEZ PAS cet équipement si cette protection est affaiblie.**

INSTRUCTIONS POUR UN FONCTIONNEMENT EN TOUTE SÉCURITÉ

TENSIONS RF DANGEREUSES

Les tensions RF sur la broche centrale d'un connecteur de sortie RF peuvent être dangereuses. Le connecteur de sortie RF doit être connecté à une charge avant que l'équipement ne reçoive l'alimentation en courant alternatif. N'entrez pas en contact avec la broche centrale du connecteur de sortie RF ou des accessoires raccordés à celle-ci. L'équipement doit être dans un état de non fonctionnement avant de déconnecter ou de connecter la charge au connecteur de sortie RF.



LIMITES ACOUSTIQUES

Si le bruit de l'équipement dépasse 80dB, une protection auditive est nécessaire.

AVERTISSEMENT CONCERNANT L'ENTRETIEN

Le réglage, l'entretien ou la réparation de l'équipement doivent être effectués uniquement par un personnel qualifié. Une énergie dangereuse peut être présente lorsque les couvercles de protection sont retirés de l'équipement, même si celui-ci est déconnecté de la source d'alimentation. Un contact peut causer des blessures. Les fusibles de remplacement doivent être d'un type et courant nominal spécifiques.

CONDITIONS ENVIRONNEMENTALES

Sauf mention contraire sur la fiche signalétique du produit, cet équipement est conçu pour être sécuritaire dans les conditions environnementales suivantes :

- Utilisation à l'intérieur
- Altitude jusqu'à 2000 m
- Température de 5°C à 40°C
- Humidité relative maximale de 80 % pour les températures jusqu'à 31°C. Décroissance linéaire à 50 % à 40°C.
- Les fluctuations de tension d'alimentation principale ne doivent pas dépasser ± 10 % de la tension nominale ou des valeurs d'autorégulation minimales et maximales.
- Degré de pollution 2 : Normalement non conducteur avec une condensation occasionnelle. Bien que l'équipement ne cause pas de condition dangereuse dans cette gamme environnementale, sa performance peut varier.

ÉQUIPEMENT CONTENANT DES LASERS



Les sondes de champ AR (série FL/PL) et les analyseurs de champ (série FA) sont des produits laser de classe 1 contenant des lasers intégrés de classe 4. Lors d'une utilisation normale, le rayonnement laser est entièrement contenu dans les câbles à fibres optiques et ne pose aucun risque d'exposition. Des verrouillages de sécurité veillent à ce que le laser ne soit pas activé à moins que les câbles ne soient correctement raccordés. Soyez toujours prudent lorsque vous utilisez ou entretenez des produits laser. Ne regardez pas directement avec des instruments optiques.

ANTENNES RF

- Cet équipement (antenne ou ensemble antenne) peut être lourd nécessitant deux personnes pour le soulever. Soyez prudent lorsque vous installez ou retirez l'unité. Respectez toutes les instructions concernant l'installation et le levage de l'équipement indiquées dans ce document.

- Assurez-vous que les connecteurs sont appropriés pour l'utilisation prévue. Les connecteurs sont indiqués dans le manuel d'utilisation et la fiche signalétique du produit.
- Ne dépassez pas le niveau d'entrée RF maximal indiqué dans les spécifications. Référez-vous au manuel d'utilisation et à la fiche signalétique du produit pour déterminer les niveaux RF applicables.
- Une entrée RF excessive pourrait endommager l'équipement ou les connecteurs causant des dangers pour la sécurité.
- Lorsque l'équipement fonctionne, les tensions RF sur les éléments de l'antenne peuvent être dangereuses. N'entrez pas en contact avec l'antenne ou les éléments lorsque le connecteur d'entrée RF est connecté à une source RF active.
- Pour éviter que le personnel ne se blesse et que l'amplificateur de puissance ou l'antenne ne soit endommagé, désactivez la sortie RF de l'amplificateur de puissance avant de brancher ou débrancher la connexion d'entrée à l'antenne.
- Effectuez des inspections périodiques de l'antenne et des systèmes de sondes de champ pour vérifier la date d'échéance de la calibration, le bon fonctionnement et l'état global de l'équipement.

MODÈLES TWT MONTÉS SUR BÂTI

Certains modèles TWT sont fournis sans le boîtier amovible proposé pour l'utilisation sur un plan de travail. Ces modèles montés sur bâti peuvent être fournis avec des poignées de transport ou des coulisses et poignées frontales. Respectez toutes les instructions de levage indiquées dans ce document et les instructions d'installation fournies dans le manuel d'utilisation TWT.

INSTRUCTIONS DE LEVAGE POUR L'ÉQUIPEMENT AR

Comme la plupart des produits doivent être manipulés pendant la distribution, l'assemblage et l'utilisation, le risque de blessures graves en raison d'une manipulation dangereuse du produit doit être une considération fondamentale pour chaque utilisateur. Une directive faisant autorité pour éliminer le risque injustifié de blessures causées par le levage est fournie par les méthodes de travail de NIOSH (publication n° 94-110) disponibles sur :



<https://www.cdc.gov/niosh/docs/94-110/pdfs/94-110.pdf>

De façon générale, respectez les directives suivantes pour lever un poids de 50 lb (22 kg) ou plus :

- Utilisez uniquement l'anneau de levage (si posé au sol) ou les poignées latérales (si sur la table) pour soulever l'unité.
- Utilisez un équipement de capacité adéquate pour soulever et supporter l'unité.
- Si vous utilisez un chariot élévateur pour déplacer l'unité, assurez-vous que les fourches sont assez longues pour s'étendre au-delà du côté de l'unité.
- Pour plus d'informations, suivez le lien indiqué ci-dessus.

INSTRUCTIES VOOR VEILIG GEBRUIK

Neem de volgende veiligheidsrichtlijnen in acht om uw persoonlijke veiligheid te helpen waarborgen en uw apparaat en werkomgeving tegen mogelijke schade te beschermen.

BEOOGD GEBRUIK

Dit apparaat is bedoeld voor algemeen laboratoriumgebruik bij het genereren, regelen en meten van niveaus van elektromagnetische radiofrequentie(RF)-energie. Zorg ervoor dat het apparaat wordt gebruikt op een locatie die de uitgestraalde energie controleert, geen letsel veroorzaakt of de reglementaire niveaus van elektromagnetische interferentie schendt.

VEILIGHEIDSSYMBOLEN

Deze symbolen kunnen in uw gebruikershandleiding of op uw apparaat verschijnen.

	Dit symbool staat op het apparaat als de gebruiker de handleiding moet raadplegen voor belangrijke veiligheidsinformatie. Het waarschuwingssymbool geeft een mogelijk gevaar aan. Er moet aandacht worden besteed aan de verklaring om schade, vernietiging of letsel te voorkomen.
	Er zijn gevaarlijke elektrische spanningen aanwezig. Wees uiterst voorzichtig.
	Wijst op een terminal aan die bedoeld is voor aansluiting op een externe geleider voor bescherming tegen elektrische schokken in het geval van een storing, of de terminal van een veiligheidselektrode (aarding).
	Wijst op een onzichtbare laserstraling - bekijk niet rechtstreeks met optische instrumenten.
	Wijst op het frame of het chassis van de aardingsterminal.
	Wijst op wisselstroom.
	Geeft aan dat dit product niet bij het huishoudelijk afval mag worden weggegooid.
	Geeft aan dat het gemarkeerde oppervlak en de aangrenzende oppervlakken temperaturen kunnen bereiken, die warm aanvoelen.

VOORZORGSMAATREGELEN BIJ DE INSTALLATIE VAN HET APPARAAT



Raadpleeg de gebruikershandleiding en leer alle veiligheidsmarkeringen en -instructies kennen. De bescherming die door het apparaat wordt geboden, kan worden belemmerd bij gebruik op een manier die niet wordt vermeld door AR RF/Microwave Instrumentation (AR).

- Respecteer alle tilinstructies die in dit document vermeld zijn.
- Plaats het apparaat op een hard, waterpas oppervlak.
- Gebruik het apparaat niet in een natte omgeving, bijvoorbeeld in de buurt van een gootsteen of in een vochtige kelder.
- Plaats uw apparaat zodanig dat de aan/uit-schakelaar gemakkelijk bereikbaar is.

Revisie 0517

- Laat een vrije ruimte van 10,2 cm (4 inch) aan alle geventileerde zijden van het apparaat om de luchtstroom die nodig is voor goede ventilatie mogelijk te maken. Belemmer de luchtstroom in het apparaat niet door ventilatieopeningen of luchtinlaten te blokkeren. Het belemmeren van de luchtstroom kan leiden tot schade aan het apparaat, onregelmatige uitvallen of veiligheidsrisico's.
- Houd het apparaat uit de buurt van extreem hoge of lage temperaturen om ervoor te zorgen dat het apparaat binnen het gespecificeerde werkbereik wordt gebruikt.
- Bij de installatie van accessoires zoals antennes, directionele koppelingen en terreinsondes, moet u ervoor zorgen dat blootstelling aan gevaarlijke RF-niveaus wordt voorkomen.
- Zorg ervoor dat er niets op de kabels van uw apparaat rust en dat de kabels zich niet op een plaats bevinden, waar er op getrapt kan worden of waar er over gestruikeld kan worden.
- Verplaats de apparatuur voorzichtig; zorg ervoor dat alle zwenkwielen en/of kabels stevig op het systeem zijn aangesloten. Vermijd plotselinge stops en oneffen oppervlakken.

VOOR HET OPZETTEN VAN DE STROOM

Uw AR-apparatuur kan meer dan een netvoedingskabel bezitten. Gebruik alleen goedgekeurde netvoedingskabel(s). Koopt een netvoedingskabel die is goedgekeurd voor gebruik in uw land als u geen netvoedingskabel hebt ontvangen voor de apparatuur of voor een door wisselstroom aangedreven optie, die bedoeld is voor de apparatuur. De netvoedingskabel moet geschikt zijn voor het apparaat en voor de spanning en stroomsterkte die op het label met de elektrische classificatie van het apparaat staat vermeld.



Het verkeerd installeren of gebruiken van een incompatibele netspanning kan het risico op brand of andere gevaren verhogen. Sluit het apparaat en de perifere netvoedingskabels aan op geaarde stopcontacten om elektrische schokken te helpen voorkomen. Deze kabels zijn uitgerust met driepolige stekkers om voor een goede aarding te zorgen. Gebruik geen adapterstekkers of verwijder de aardingspen van een kabel niet.

Pas geen netvoedingskabels of stekkers aan. Raadpleeg een bevoegde elektricien of een door AR opgeleide servicemonteur voor aanpassingen van de apparatuur. Respecteer altijd uw lokale/nationale bedravingsreglementering.



Gebruik de apparatuur niet als er sprake is van fysieke schade, ontbrekende hardware of ontbrekende panelen.

AARDING



Deze apparatuur is voorzien van een beschermende aardingsterminal. De stroombron van de apparatuur moet een ononderbroken veiligheidsaarding van voldoende grootte leveren om de aansluitklemmen, de netvoedingskabel of de meegeleverde netvoedingskabelset aan te sluiten. **GEBRUIK dit apparaat NIET als deze bescherming is beschadigd.**

INSTRUCTIES VOOR VEILIG GEBRUIK

GEVAARLIJKE RF-SPANNINGEN

De RF-spanning op de middelste pin van een RF-outputconnector kan gevaarlijk zijn. De RF-uitgangconnector moet op een massa worden aangesloten voordat er wisselstroom op het apparaat wordt geplaatst. Raak de middelste pin van de RF-outputconnector of de accessoires die erop zijn aangesloten, niet aan. Plaats het apparaat in een niet-werkende staat voordat u de massa loskoppelt of verbindt met de RF-outputconnector.



AKOESTISCHE BEPERKINGEN

Als het geluid van het apparaat 80dB overschrijdt, is gehoorbescherming vereist.

ONDERHOUD WAARSCHUWING

Aanpassing, onderhoud of reparatie van de apparatuur mag alleen worden uitgevoerd door gekwalificeerd personeel. Er kan gevaarlijke energie aanwezig zijn terwijl beschermende afdekkingen van de apparatuur worden verwijderd, zelfs als deze van de stroombron is losgekoppeld. Contact kan tot persoonlijk letsel leiden. Wisselzekeringen moeten van het hetzelfde type en dezelfde stroomsterkte zijn.

OMGEVINGSVOORWAARDEN

Tenzij anders op het productspecificatieblad is vermeld, is dit apparaat ontworpen om veilig te zijn onder de volgende omgevingsomstandigheden:

- Binnengebruik
- Hoogte tot 2000 m
- Temperatuur van 5 °C to 40 °C
- Maximale relatieve vochtigheid 80% voor temperaturen tot 31 °C. Lineair afnemend tot 50% bij 40 °C.
- Schommelingen in de netspanning mogen niet groter zijn dan $\pm 10\%$ van de nominale spanning of minimum en maximum autobereikwaarden.
- Vervuilinggraad 2: Normaal niet-geleidend met incidentele condensatie. Hoewel het apparaat geen gevaarlijke toestand veroorzaakt boven dit omgevingsbereik, kunnen de prestaties variëren.

APPARAAT DAT LASERS BEVAT



AR-terreinsondes (FL/PL-serie) en terreinanalysatoren (FA-serie) zijn laserproducten van klasse 1 met ingesloten klasse 4-lasers. Bij normaal gebruik is de laserstraling volledig vervat in de glasvezelkabels en vormt ze geen bedreiging voor blootstelling. Veiligheidsvergrendelingen zorgen ervoor dat de laser niet wordt geactiveerd, tenzij de kabels correct zijn aangesloten. Wees altijd voorzichtig bij het gebruik of het onderhoud van laserproducten. Bekijk niet rechtstreeks met optische instrumenten.

RF-ANTENNES

- Dit apparaat (antenne of antenne-set) kan zwaar zijn, waardoor er twee personen nodig zijn om het op te tillen. Wees voorzichtig bij het installeren of verwijderen van het apparaat. Respecteer alle instructies voor het instellen en optillen van de apparatuur, die in dit document worden vermeld.
- Zorg ervoor dat de connectoren geschikt zijn voor de beoogde werking. De connectoren worden gespecificeerd in de gebruikershandleiding en in het productspecificatieblad.
- Overschrijd het maximale RF-ingangsniveau niet, dat in de specificaties is vermeld. Raadpleeg de gebruikershandleiding en het productspecificatieblad om de toepasselijke RF-niveaus te bepalen.
- Een overmatige RF-input kan het apparaat of de connectoren beschadigen en veiligheidsrisico's veroorzaken.
- De RF-spanningen op de antenne-elementen kunnen gevaarlijk zijn tijdens het gebruik. Raak de antenne of elementen niet aan wanneer de RF-ingangconnector is aangesloten op een actieve RF-bron.
- Om persoonlijk letsel en onopzettelijke schade aan de vermogensversterker of antenne te voorkomen, schakelt u de RF-output van de vermogensversterker uit voordat u de inputaansluiting op de antenne aansluit of loskoppelt.
- Voer periodieke inspecties uit van de antenne- en terreinsondesystemen om de vervaldatum van de kalibratie, de juiste werking en de algehele conditie van de apparatuur te controleren.

IN EEN REK GEMONTEERDE TWT-MODELLEN

Sommige TWT-modellen worden geleverd zonder de verwijderbare behuizing die wordt aangeboden voor gebruik als tafemodel. Deze modellen die in een rek kunnen worden gemonteerd, kunnen worden geleverd met handgrepen of sledes en handgrepen die aan de voorkant zijn geïnstalleerd. Volg alle tilinstructies in dit document en de installatie-instructies in de gebruikershandleiding van de TWT.

TILINSTRUCTIES VOOR AR-APPARATUUR

Omdat de meeste producten tijdens de distributie, de assemblage en het gebruik moeten worden behandeld, moet het risico op ernstig letsel als gevolg van een onveilige behandeling van het product een fundamentele overweging voor elke gebruiker zijn. Een gezaghebbende richtlijn voor het elimineren van ongerechtvaardigd risico op letsel veroorzaakt door tillen, wordt aangeboden door de NIOSH-Work Practices (publicatie # 94-110) en is beschikbaar op:



<https://www.cdc.gov/niosh/docs/94-110/pdfs/94-110.pdf>.

Neem in het algemeen de volgende richtlijnen in acht voor het optillen van een gewicht van 25 kg of meer:

- Gebruik alleen het hijsorg (vloermodel) of de zijhandgrepen (tafelmodel) om de eenheid op te tillen.
- Gebruik apparatuur met voldoende capaciteit om de eenheid op te tillen en te ondersteunen.
- Als u een vorkheftruck gebruikt om de eenheid te verplaatsen, zorg er dan voor dat de vorken lang genoeg zijn om tot voorbij de zijkant van het eenheid uit te steken.
- Volg de link hierboven voor meer informatie.

ADDENDUM

This amplifier may contain assemblies fabricated using both leaded and lead-free solders. These solders are not compatible with one another and care must be taken to use the appropriate process when repairing these assemblies.

All assemblies in this unit that were assembled using a lead-free process are identified on the PCB using the lead-free symbol shown at right. Any PCB bearing this symbol should be repaired using a SAC305 or compatible lead-free solder.



Assemblies that do not bear the lead-free symbol can be assumed to contain lead solder and should be repaired with the same.

TABLE OF CONTENTS

ADDENDUM.....	i
TABLE OF CONTENTS	i
1. GENERAL INFORMATION	1
1.1 General Description	1
1.2 Specifications.....	1
1.3 Power Supplies	2
1.4 Protection Circuits	2
1.5 Installation	2
1.5.1 Location	2
1.5.2 AC Power.....	3
1.6 Connectors	3
1.6.1 Amplifier Input Connector.....	3
1.6.2 Amplifier Output Connector.....	3
1.6.3 Safety Interlock Connector	3
1.6.4 Communications Connectors	3
2. OPERATING INSTRUCTIONS.....	7
2.1 General.....	7
2.2 Control and Indicator Functions	7
2.2.1 Keylock Switch.....	7
2.2.2 Power Switch	7
2.2.3 Main Power Circuit Breaker	8
2.2.4 RF ON/OFF	9
2.2.5 Reset Function	9
2.3 Digital Control Panel (DCP) Operations	9
2.3.1 Amplifier Operating Mode	10
2.3.2 Adjusting Amplifier Controls	10
2.4 Inputs and Outputs	11
2.4.1 RF Input	11
2.4.2 RF Output	11
2.4.3 IEEE-488, USB, and RS-232 Interfaces	11
2.4.4 Safety Interlock Connector	11
2.5 Amplifier Operation.....	12
2.5.1 CW Mode.....	12
2.5.2 Bridge Mode	13
2.5.3 Parallel Mode.....	14
2.6 Remote Communications.....	15
2.6.1 IEEE-488 (GPIB) Communications	15
2.6.2 RS-232 Communications.....	16
2.6.3 Fiber-Optic Serial Communications	16
2.6.4 USB Communications	17
2.6.5 Ethernet Communications.....	17
2.6.6 Remote Commands.....	18
3. THEORY OF OPERATION	27
3.1 General.....	27

3.2	Amplifier	27
3.2.1	Amplifier RF Input.....	27
3.2.2	Variable Gain Amp	27
3.2.3	350W Module.....	27
3.3	Power Supply	27
3.4	Control Circuits.....	28
3.4.1	Power On/Operate Circuits	28
3.4.2	A13 ALC Board (Schematic #10023927)	28
3.5	Fault Detection Circuits.....	29
3.5.1	Thermal Faults.....	29
3.5.2	Power Supply Faults.....	29
3.5.3	ALC Fault.....	29
3.5.4	Interlocks.....	29
4.	TROUBLESHOOTING AND REPAIR.....	31
4.1.	General	31
4.2	Fault Signal Interpretation and Diagnosis	31
4.2.1	General - Reading faults.....	32
4.2.2	Power Supply Fault	32
4.2.3	Thermal Faults.....	32
4.2.4	ALC Fault.....	32
LIST OF FIGURES		
2-1	Digital Control Panel (DCP) Features.....	8
2-2	Rear Panel Features	8
2-3	Touch Panel Display Menu Map.....	10
2-4	Typical Setup - CW Mode.....	12
2-5	Typical Setup – Bridge Mode	13
2-6	Typical Setup – Parallel Mode	14
LIST OF TABLES		
2-1	IEEE-488 Address Selection	15
2-2	RS-232 Port Settings	16
2-3	RS-232 (DCE) Port Pinout Diagram DB-9 Female	16
2-4	Relationships between Amplifier Controls and Responses.....	19

1. GENERAL INFORMATION

1.1 GENERAL DESCRIPTION

The Model 350AH1A is a self-contained, air-cooled, broadband, solid-state, extended range audio amplifier designed for applications where instantaneous bandwidth and high gain are required. The Model 350AH1A, when used with a RF sweep generator, will provide up to 350 watts of swept power covering the frequency range from 10kHz to 1MHz. The Model 350AH1A is housed in a single stylish contemporary equipment cabinet.

Special features incorporated into the Model 350AH1A include the following:

- **A Digital Control Panel (DCP)** that allows both local and remote (via a computer interface) control of the amplifier (including adjustment of the amplifier's RF Gain) and provides graphical displays of the amplifier's voltage and current output levels.
- **Output level protection**
- **An internal voltage and current detector**
- **Output phase control, 0° or 180° shift**
- **A General Purpose Interface Bus (GPIB)/IEEE-488.2 interface** for remote control of the amplifier's operating functions.
- **RS232 serial communications** for remote control
- **USB Communication port** for remote control
- **Ethernet Communications port** for remote control
- **Protection** is provided by DC current limiting, over-temperature shut down and output current limiting.
- **Housed in a stylish contemporary equipment cabinet**, the Model 350AH1A provides readily available RF power for typical applications such as RF susceptibility testing and magnetic field generation.

1.2 SPECIFICATIONS

Refer to the AR RF/Microwave Instrumentation Data Sheet at the end of this section for detailed specifications.

1.3 POWER SUPPLIES

The Model 350AH1A has three regulated switching power supplies with a combined normal power consumption of approximately 1200 watts at the amplifier full rated output power. These power supplies are self-contained, regulated switching units. One unit supplies $\pm 48\text{V}$, as the main source of power for the amplifier circuitry. Another supplies $+24\text{V}$ for the fans. The last supplies $+5\text{V}$, $+15\text{V}$ and -15V for control and logic.

1.4 PROTECTION CIRCUITS

Features incorporated into this unit include DC current limiting, output level protection circuits, thermal protection circuits and output voltage and current monitoring. There is protection for the AC main circuit. All switching supplies are short circuit protected. Reaching a threshold of either the DC current or output current limit adjustments, which are adjusted to approximately 8 amps and 15 amps respectively, will initiate limiting, or smooth drive level fold-back, in a low-level stage of the amplifier chain. If the limiting circuits cannot keep the amplifier's levels below the limit threshold, the protection circuits will invoke a shut down of the amplifier. A **RESET** function is provided to permit re-powering of the amplifier in case of transient or temporary activation of the amplifier's protection circuitry. The output amplifier subassembly is thermally monitored.

The digital control panel monitors all fault signals, stores and displays any that are invoked and asserts the required action.

1.5 INSTALLATION

Before proceeding, thoroughly inspect the amplifier for signs of physical damage that may have been incurred during shipment and completely read the following installation and operating instructions, paying special attention to all **CAUTION** notes.

1.5.1 Location

Select an operating location that will permit free air circulation around the amplifier's cabinet. The Model 350AH1A utilizes air cooling and should be located where the normal flow of air into or exiting from the unit will not be restricted, diverted, or re-circulated through the unit itself. For example, do not position the unit next to a wall or other equipment that would cause a restriction of airflow into or out of the unit.



CAUTION:

Under normal operating conditions, the exhaust air temperature may exceed 40°C . Do not locate heat sensitive equipment, objects or materials in the exhaust air stream of the unit.

1.5.2 AC Power

The Model 350AH1A is designed for a primary power input of 90–260 VAC, 47/63 Hz, single phase.



CAUTION:

Dangerous voltages are present in the amplifier whenever it is plugged into an AC outlet. Always disconnect the AC power line to the amplifier before servicing the unit.

1.6 CONNECTORS

1.6.1 Amplifier Input Connector

The RF input connector for the amplifier is located on the left side of the control panel. It is a female, Type BNC connector.

1.6.2 Amplifier Output Connector

The amplifier output connector is a 5-way binding post located on the right side of the control panel.

1.6.3 Safety Interlock Connector

Located on the left side of the rear panel, as viewed from the rear, are the remote interface connectors and safety interlock connectors. The 15-pin D-sub miniature female safety interlock connector provides two separate interlock loops. Pins 1 and 8 are used for situations where the amplifier can be left on, but forced into STANDBY mode. This interlock is called Inhibit Interlock. Pins 10 and 14 are used for situations that demand the safest possible condition, with the AC power to all main circuits disconnected. This interlock is called AC Interlock. Both loops must be closed, or jumpered, for normal operation.

1.6.4 Communications Connectors

1.6.4.1 RS232 Wire

Standard 9-pin D-subminiature female connector is provided on the rear panel.

1.6.4.2 IEEE-488

A standard 44-pin female GPIB panel connector is provided on the rear panel.

1.6.4.3 USB

A standard USB-B connector is provided on the rear panel.

1.6.4.4 Ethernet

A standard RJ-45 connector is provided on the rear panel.



350AH1A

- M1 through M3
- 350 Watts CW
- 10Hz–1MHz



Features

The Model 350AH1A amplifier is a portable, self-contained, air-cooled, broadband, solid state amplifier unit designed for laboratory applications where instantaneous bandwidth, high gain and moderate power output are required. When used with an RF sweep generator, the 350AH1A will provide up to 350 watts of output power.

Housed in a stylish contemporary enclosure, the unit provides instantaneous power for typical applications such as magnetic susceptibility testing, 4–10 kHz requirement of CS114 of MIL-Std-461F, antenna and component testing, watt-meter calibration and as a driver for higher power amplifiers.

The 350AH1A is powered by a high efficiency switching supply, with autoringing AC input circuitry which will automatically accept voltages from 90 to 260 VAC in the 47 to 63 Hz frequency range. The RF amplifier stages are protected from over-temperature and over-current conditions by removing the DC voltage to them when a fault

is detected. The touch screen display on the front panel indicates the operational status and any pending fault conditions when an over-temperature, over-current or power supply fault has occurred. The unit can be returned to normal operation when the condition has been cleared. The unit also includes digital control for both local and remote control of the amplifier. The RISC microprocessor controller board provides IEEE-488 (GPIB), USB, Ethernet and asynchronous full duplex RS-232 communication control of all amplifier functions.

Two 350AH1A amplifiers may be used together in a “bridged” output configuration by supplying the same signal to both amplifiers and using the internal signal inversion feature of one amplifier. The amplifier output grounds are connected and the load is placed across the two amplifier outputs.

The export classification for this equipment is EAR99. These commodities, technology or software are controlled for export in accordance with the U.S. Export Administration Regulations. Diversion contrary to U.S. law is prohibited.

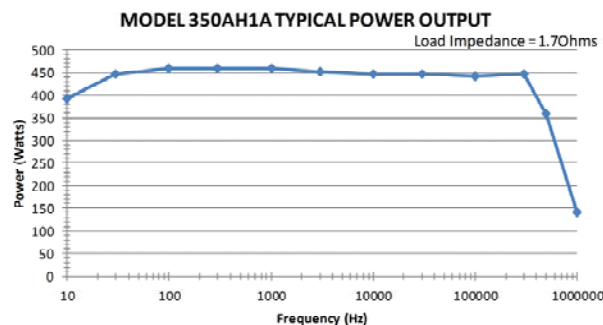
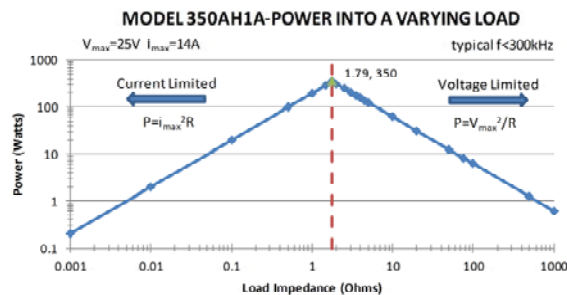

AR RF/Microwave
Instrumentation
160 School House Rd
Souderton, PA 18964
215-723-8181

For an applications engineer call: 800.933.8181

www.arworld.us



350AH1A

- M1 through M3
- 350 Watts CW
- 10Hz–1MHz

Specifications

OPERATION: Class AB Linear

FREQUENCY RESPONSE: 10Hz–1 MHz instantaneously

POWER OUTPUT (1.79 Ohm load)
CW, Minimum:
350 watts, 10Hz–300kHz
350–55 watts, 300kHz–1MHz
Voltage Output, Minimum
25 Vrms, 10Hz–300kHz
25-10 Vrms, 300kHz–1MHz
Current Output, Minimum
14 Arms, 10Hz–300kHz
14–5.5 Arms, 300kHz–1MHz

FLATNESS: ±1.0 dB, 10Hz–300kHz
±4.0 dB, 300kHz–1MHz

GAIN (POWER): 47 dB minimum, 10Hz–300kHz
39 dB minimum, 300kHz–1MHz

POWER GAIN CONTROL RANGE: 48 dB minimum

INPUT SIGNAL: 0–2 Vrms

INPUT IMPEDANCE: 600 Ohms typical

OUTPUT IMPEDANCE: < 1Ω typical

MISMATCH TOLERANCE: 100% of rated power without fail.

MODULATION CAPABILITY: Will faithfully reproduce AM, FM, or pulse modulation appearing on the input signal

PRIMARY POWER: 90–260 VAC; 47 to 63 Hz, single phase, 1200 watts maximum

CONNECTORS:
RF INPUT Type BNC female
RF OUTPUT 5-way binding posts
REMOTE CONTROL
IEEE-488 24 pin female
RS-232 9 pin subminiature D (female)
USB Type B (female)
Ethernet RJ-45

REMOTE INTERLOCK: 15 pin subminiature D

COOLING: Forced air (self contained fans)

EXPORT CLASSIFICATION: EAR99

Model Configurations

MODEL NUMBER	RF CONNECTOR LOCATION	INSTRUMENT CASE	WEIGHT	SIZE (W x H x D)
350AH1A	Front Panel	Yes	25 kg (55.0 lb)	50.3 x 19.9 x 37.6 cm
350AH1AM1	Rear Panel	No	18.2 kg (40.0 lb)	48.3 x 17.8 x 37.6 cm
350AH1AM2	Rear Panel	Yes	25 kg (55.0 lb)	50.3 x 19.9 x 37.6 cm
350AH1AM3	Front Panel	No	18.2 kg (40.0 lb)	48.3 x 17.8 x 37.6 cm

2. OPERATING INSTRUCTIONS

2.1 GENERAL

Operation of the Model 350AH1A broadband amplifier is quite simple. The amplifier's input signal, whether swept or fixed in frequency, is fed into the jack marked **INPUT**, and the amplifier's output signal is taken from the jack labeled **OUTPUT**. The unit is turned on by activating the front panel **POWER** switch. In the event of a major malfunction, protection is provided by a circuit breaker located on the unit's rear panel.



CAUTION:

The Model 350AH1A Amplifier is *typically* not critical in regard to source and load Voltage Standing Wave Ratio (VSWR) and will remain unconditionally stable with any magnitude and phase of source and load VSWR. It has also been designed to withstand, without damage, RF input levels much greater than its rated input of 2Vrms. However, large signal levels or transients with high peak voltages can damage the amplifier. Also, accidental connection of the Model 350AH1A's output to its input (either through direct connection or parasitic feedback paths) will cause oscillations that may permanently damage the unit's input transistors.

2.2 CONTROL AND INDICATOR FUNCTIONS

The Model 350AH1A's front panel is shown in Figure 2-1; the unit's rear panel features are detailed in Figure 2-2.

2.2.1 Keylock Switch

The Keylock Switch is provided for protection from unauthorized use or unexpected remote control of the amplifier. The amplifier can only be turned on locally when the Keylock Switch is in the **LOCAL** position. Likewise, the unit can only be turned on or controlled remotely when the Keylock Switch is in the **REMOTE** position. Placing the Keylock Switch in the **INHIBIT** position places the amplifier in the off mode and disconnects primary AC power from all circuits except for the CPU and control circuits.

2.2.2 POWER Switch

The momentary **POWER** switch turns the main power to the amplifier on and off. The status of the green light-emitting diode (LED) in the switch indicates whether the amplifier's power is on or off. The main fans are active when power is on. The graphic display is active as long as the main power circuit breaker CB1 on the rear panel is on.

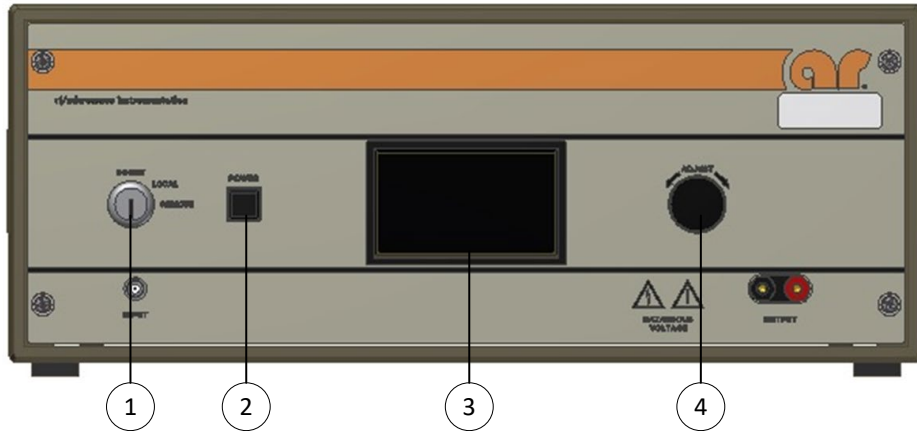

Figure 2-1. Digital Control Panel (DCP) Features

Item	Title	Function
1	INHIBIT, LOCAL, REMOTE	Keylock Switch, 3-position; key removal in INHIBIT position only
2	POWER	POWER control with indicator LED
3	DISPLAY	Numerous parameter values and fault messages
4	ADJUST	Adjust knob to change selected variables

2.2.3 Main Power Circuit Breaker

The Main Power circuit breaker, CB1, is located on the rear panel of the cabinet.

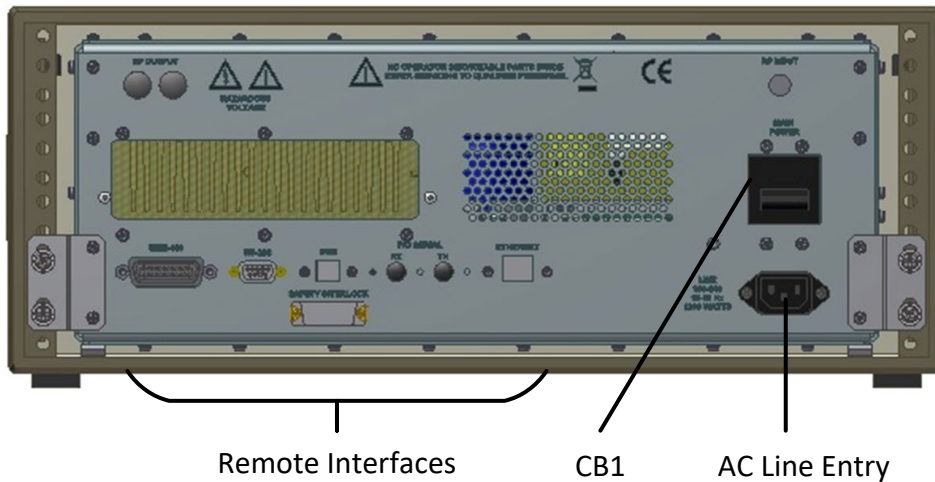

Figure 2-2. Rear Panel Features

2.2.4 RF ON/OFF

The RF ON/OFF touch screen button toggles the amplifier from a Standby to an Operate mode. The status of the function is indicated on the display as RF ON or RF OFF. In the RF ON state, RF output is enabled according to control settings and amplifier RF input. Main cooling fans will operate. In the RF OFF state, there will be no RF output.

2.2.5 RESET Function

The RESET function, selected by the touch screen button, will cause the amplifier to attempt to reset. Selecting Reset may clear the fault, depending upon the type of fault that has occurred. If the amplifier is in an over-driven condition, lowering the amplifier's gain or RF input level should enable the function to reset the amplifier.

2.3 DIGITAL CONTROL PANEL (DCP) OPERATIONS

The operations described in this section assume that the user is performing these operations from the amplifier's front panel with the Keylock Switch in the LOCAL position. Remote control using a personal computer is available when the Keylock Switch is set to REMOTE. Refer to Section 2.5.5 for information on remote operation.

Amplifier functions are visually monitored on the front panel display. POWER is controlled by a dedicated push-button switch to the left of the display. The safety Keylock Switch is located to the lower left of the display.

In the center of the digital control panel is the graphic touch display. It is used to provide amplifier status information and a set of menu functions for controlling the amplifier. The menu selections are typically found as software generated buttons on the right side of the display screen. In some cases, these buttons can also be found in other areas of the screen. From the MAIN MENU the user can access the RF ON/OFF button. The RF ON/OFF button causes the power amplifier sections to produce RF output power from the output connector, based on the various settings and the input level to the amplifier.

To the far right is an ADJUST knob. This knob is used to adjust many of the variables shown on the graphic touch display.

The graphic touch display is active and illuminated whenever AC power is supplied to the unit and the main circuit breaker is on.

At the top of the Main Menu screen is a bar graph and numeric value (blue) which is used to indicate the adjustable parameter of RF Gain from 0% - 100%.

Below the adjustment value section is an indicator for the RF state and the amplifier mode. The RF state can be changed using the RF On/Off button found in the lower right of the Main Menu.

Below the RF state indicator is the amplifier mode indicator. Possible modes are Manual, Pulse, ALC Internal, and ALC External. (Not all modes are available on every amplifier.) The amplifier mode can be changed using the Mode button from the Main Menu.

Toward the bottom of the display are two bar graphs and two numeric values used to indicate the RMS Current and RMS Voltage (green and red respectively).

General Display Navigation is shown in Figure 2-3, **Touch Panel Display Menu Map**.

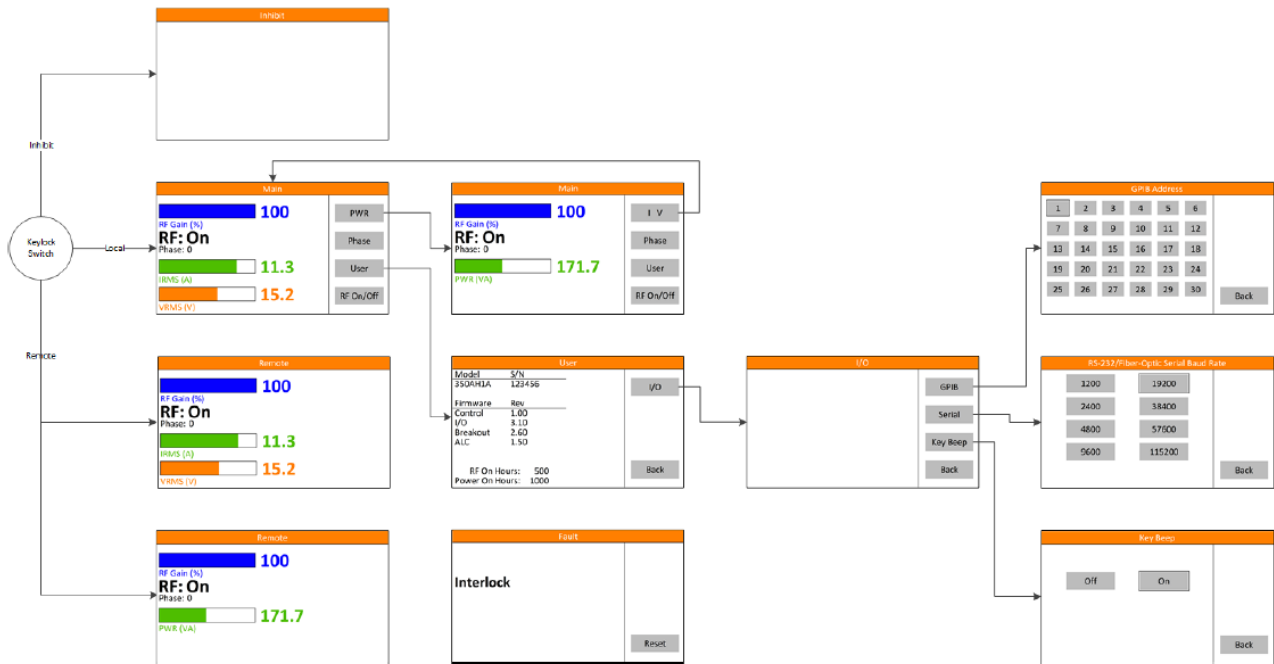

Figure 2-3. Touch Panel Display Menu Map

2.3.1 Amplifier Operating Mode

The 350AH1A amplifier always operated in a CW mode.

In the CW mode, the amplifier’s RF output level is controlled by the input drive level and the RF Gain control. This mode provides no automatic control of the amplifier’s RF output level other than that provided by the amplifier’s protective circuitry.

2.3.2 Adjusting Amplifier Controls

All adjustments to control the operation of the Model 350AH1A are made using the dedicated controls, display menus and adjust knob functionality.

2.3.2.1 RF GAIN Control

The RF GAIN control, which has a minimum of 15dB of range, is used to adjust the gain of the variable gain module. This control adjusts the output power level for a fixed input power level.

To adjust the RF Gain value, use the adjust knob. Please note that the display panel is limited in resolution compared to the control signals, which are generated and sent to the variable gain module. A small rotation that may not show any change on the display may, in fact, cause very small, precise changes in the amplifier’s RF output.

2.3.2.2. Output Phase Control

The phase of the output signal can be shifted by 180 degrees. This phase shift is necessary when using two 350AH1A amplifiers in a bridged configuration.

NOTE: The phase shift adjustment is only active when the amplifier is in the RF OFF mode.

To change the phase, press the **PHASE** softkey. Each press of the **PHASE** softkey will change the phase by 180 degrees. The current phase is indicated on the front panel display as PHASE 0 or PHASE 180.

2.4 INPUTS AND OUTPUTS

The input and output connectors described in the following sections are located on the unit's front or rear panels; refer to the Front and Rear Panel Features drawings (Figure 2-1, Figure 2-2).

2.4.1 RF Input

This Type BNC connector is the RF input to the amplifier. It should be connected to a RF signal generator or sweep generator.

2.4.2 RF Output

This 5-way binding post connector is the RF output of the amplifier.

CAUTION:



Do not connect or disconnect any loads or cables from the amplifier's RF Output when the amplifier is in the Operate mode. Dangerous voltages that could cause serious injury to the user exist at the RF Output when the amplifier is under power.

2.4.3 IEEE-488, USB, and RS-232 Interfaces

The Model 350AH1A's remote interfaces allow remote control, via a computer, of all amplifier functions (except for the Keylock Switch position) that can be controlled from the front panel. When the amplifier is in the Remote mode (as determined by the position of the Keylock Switch), a special Remote display is shown (see Figure 2-3). Front panel controls are deactivated, except for the Keylock Switch, which can be rotated to LOCAL or INHIBIT in order to prevent remote control commands from being executed.

Refer to section 2.5.2 for information on remote operation of the amplifier.

2.4.4 Safety Interlock Connector

The safety interlock connector interface provides for external safety switch interlocks that will prevent the amplifier from entering or being placed in the Operate mode unless an external connection is made. A connection between Pins 1 and 8 must be completed to operate the amplifier. A second interlock circuit removes primary AC power from the main power supplies when it is not closed. This circuit is found on pins 10 and 14.

2.5 AMPLIFIER OPERATION

2.5.1 CW Mode

This section describes how a single 350AH1A amplifier would be used in CW mode. A block diagram of a typical set-up is shown in Figure 2-4, **Typical Setup—CW Mode**.

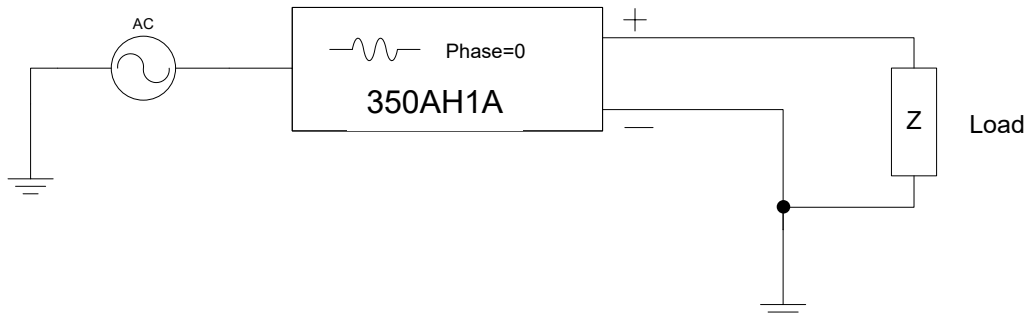

Figure 2-4. Typical Setup—CW Mode

2.5.1.1 Preliminary Settings

RF GAIN: 0%
POWER: ON
RF ON/OFF OFF
RF Generator: 0Vrms

2.5.1.2 Level Setting

Set the RF Generator output to approximately 2Vrms. Place the unit in the RF ON mode by pressing the **RF ON/OFF** button. Adjust the amplifier gain control for the desired output level.

CAUTION:



Do not connect or disconnect any loads or cables from the amplifier's RF Output when the amplifier is in the Operate mode. Dangerous voltages that could cause serious injury to the user exist at the RF Output when the amplifier is under power.

2.5.2 Bridge Mode

This section describes how a pair of 350AH1A amplifiers may be used in a bridge configuration. The bridged configuration allows for a larger voltage swing than possible with a single amplifier by inverting the second amplifier and connecting the load between the two outputs. A block diagram of a typical set-up is shown in Figure 2-5, **Typical Setup–Bridge Mode**.

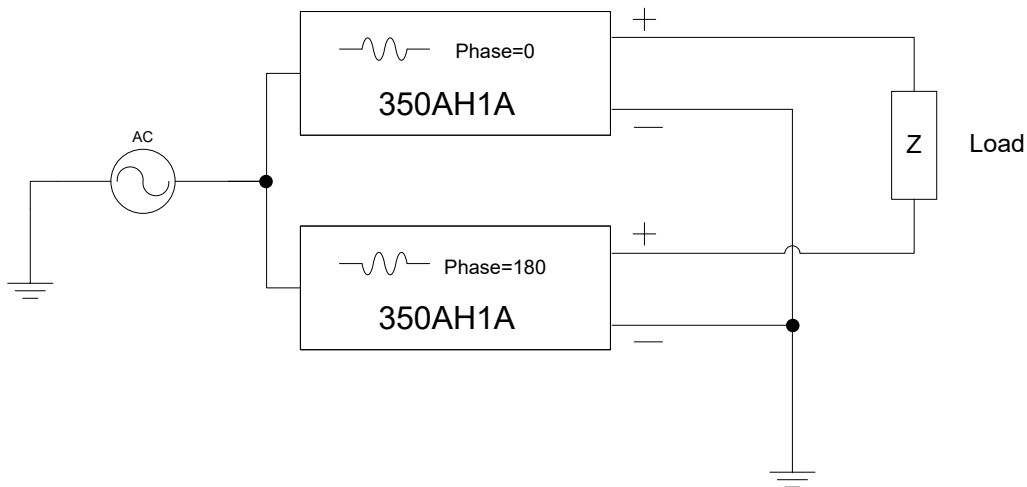

Figure 2-5. Typical Setup–Bridge Mode

2.5.2.1 Preliminary Settings

RF GAIN: 100%
 POWER: ON
 RF ON/OFF OFF
 RF Generator: 0Vrms

2.5.2.2 Level Setting

Set one of the two amplifiers PHASE to 180 degrees and the other to 0 degrees by pressing the **PHASE** buttons. Place both units in the RF ON mode by pressing the **RF ON/OFF** button. Adjust the RF Generator output to reach the desired output level.



CAUTION:

Do not connect or disconnect any loads or cables from the amplifier's RF Output when the amplifier is in the Operate mode. Dangerous voltages that could cause serious injury to the user exist at the RF Output when the amplifier is under power.

2.5.3 Parallel Mode

This section describes how a pair of 350AH1A amplifiers may be used in a parallel configuration. A parallel configuration allows for more current to be delivered into a common load by using two or more amplifiers operating together in phase. A block diagram of a typical set-up is shown in Figure 2-6, **Typical Setup—Parallel Mode**.

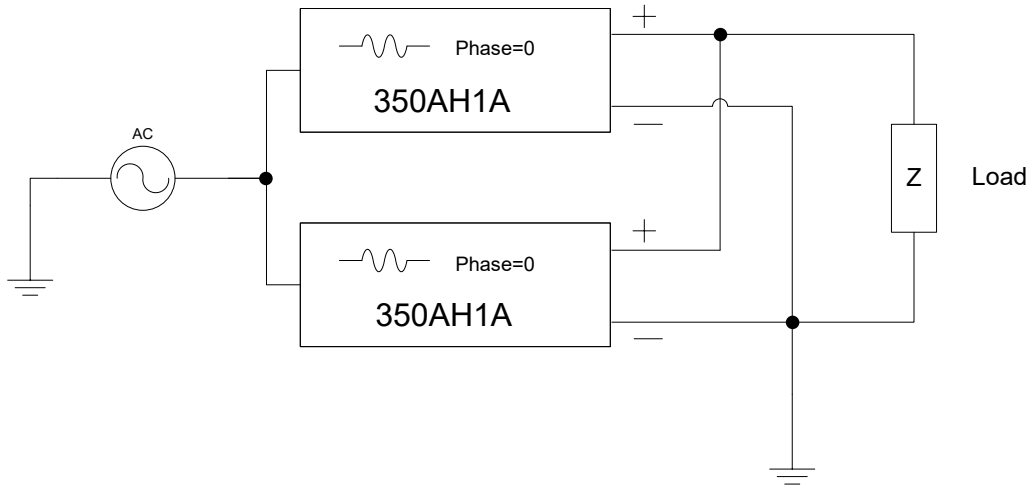

Figure 2-6. Typical Setup—Parallel Mode

2.5.3.1 Preliminary Settings

RF GAIN: 100%
 POWER: ON
 RF ON/OFF OFF
 RF Generator: 0Vrms

2.5.3.2 Level Setting

Set all of the amplifiers PHASE to either 180 degrees or 0 degrees by pressing the **PHASE** buttons. Place all units in the RF ON mode by pressing the **RF ON/OFF** button. Adjust the RF Generator output to reach the desired output level.

CAUTION:



Do not connect or disconnect any loads or cables from the amplifier’s RF Output when the amplifier is in the Operate mode. Dangerous voltages that could cause serious injury to the user exist at the RF Output when the amplifier is under power.

2.6 REMOTE COMMUNICATIONS

This section describes remote operation of the model 350AH1A using the provided General Purpose Interface Bus (GPIB), RS-232, Fiber-Optic Serial, Universal Serial Bus (USB), and Ethernet ports connected to a remote device such as a personal computer. All ports are active at all times, however only one port may be used at a time. Communicating through two or more ports at one time will cause data collisions and lost commands or queries.

The Keylock switch on the control panel of the model 350AH1A allows it to be controlled using remote communications. All remote queries will work in any Keylock switch position, but all remote commands will only work when the position is set to REMOTE. When the Keylock switch is set to REMOTE all front panel controls are disabled unless otherwise specified.

2.6.1 IEEE-488 (GPIB) Communications

For GPIB operation, the device address is set using the front panel touch screen. Ensure that each device connected to the GPIB is set to a unique address.

To send commands be sure that the model 350AH1A's address is set properly and that the controller has correctly identified it as a "listening" device.

When sending commands via the GPIB interface, terminate with an EOI, a Line Feed character or both. The 350AH1A will ignore characters following the termination.

2.6.1.1 Setting the IEEE-488 (GPIB) Address

The GPIB device address can be set to any number between 1 and 30. This selection is made by navigating to the GPIB address selection screen. To get there from the Main Menu, touch the User menu button followed by the I/O menu button and finally the GPIB menu button. Touching any of the buttons labeled 1 to 30 immediately sets the GPIB address to the corresponding value. A thin black outline indicates the present GPIB address selection. When the back button is pushed the address selection is stored to non-volatile memory. Therefore, if power is lost prior to hitting the back button, any address selection changes will be lost. The default GPIB address is 1.

Table 2-1. IEEE-488 Address Selection

Device Address	Switch 5	Switch 4	Switch 3	Switch 2	Switch 1
1	off (0)	off (0)	off (0)	off (0)	on (1)
2	off (0)	off (0)	off (0)	on (1)	off (0)
3	off (0)	off (0)	off (0)	on (1)	on (1)
4	off (0)	off (0)	on (1)	off (0)	off (0)
5	off (0)	off (0)	on (1)	off (0)	on (1)
:					
30	on (1)	on (1)	on (1)	on (1)	off (0)

2.6.2 RS-232 Communications

The RS-232 port is a serial communications bus. All commands and queries through this port must be terminated with a Line Feed character. When a valid query is received, it is processed and the result is immediately transmitted back over the RS-232 interface. This port is designed to time-out if there is no activity on the bus for more than 5 seconds. At this time, the internal buffer is cleared and a TIMEOUT_ERROR message followed by a Line Feed character is sent out from this port.

The baud rate for the RS-232 port is user selectable from the RS-232/Fiber-Optic Serial Baud Rate selection screen. To get there from the Main Menu, touch the User menu button followed by the I/O menu button and finally the Serial menu button. A thin black outline indicates the present baud rate selection. When the back button is pushed the baud rate selection is stored to non-volatile memory. Therefore, if power is lost prior to hitting the back button, any baud rate selection changes will be lost. The default baud rate is 19200.

NOTE: This baud rate setting is shared by both the RS-232 port and the Fiber-Optic serial port.

The RS-232 port is setup as a Data Circuit-terminating Equipment (DCE) port. When connecting to a Personal Computer (PC) a straight one-to-one cable should be used. A null modem is NOT needed. The settings and pinout diagram for this port can be found below.

Table 2-2. RS-232 Port Settings

Word Length	8 bits
Stop Bits:	1
Baud Rate:	User selectable (default is 19200)
Parity:	None
HW Handshake:	None

Table 2-3. RS-232 (DCE) Port Pinout Diagram DB-9 Female

Pin 1	DCD
Pin 2	TD
Pin 3	RD
Pin 4	DTR
Pin 5	GND
Pin 6	DCR
Pin 7	CTS
Pin 8	RTS
Pin 9	Unused

2.6.3 Fiber-Optic Serial Communications

The Fiber-Optic port is a serial communications bus. All commands and queries through this port must be terminated with a Line Feed character. When a valid query is received, it is processed and the result is immediately transmitted back over the Fiber-Optic interface. This port is designed to time-out if there is no activity on the bus for more than 5 seconds. At this time, the internal buffer is cleared and a TIMEOUT_ERROR message followed by a Line Feed is sent out from this port.

The baud rate for the Fiber-Optic Serial port is user selectable from the RS-232/Fiber-Optic Serial Baud Rate selection screen. To get there from the Main Menu, touch the User menu button followed by the I/O menu button and finally the Serial menu button. A thin black outline indicates the present baud rate selection. When the back button is pushed the baud rate selection is stored to non-volatile memory. Therefore, if power is lost prior to hitting the back button, any baud rate selection changes will be lost. The default baud rate is 19200.

NOTE: This baud rate setting is shared by both the Fiber-Optic serial port and the RS-232 port.

The Fiber-Optic port provides the user with the ability to optically isolate the controlling PC from the model 350AH1A. This can be useful in an environment where RF/Microwave energy could be coupled onto a connection to one of the “wired” communications ports and fed back to the controlling PC.

Both optical connections (TX and RX) are optimized to work with light at a wavelength of 820nm. For more detailed specifications on this port, consult the Avago HFBR series datasheet found at www.avagotech.com.

A glass, multi-mode, fiber-optic cable of 200um is recommended, however fiber-optic cable as small as 50um can be used. The connector type for this port is ST.

This port can be used in conjunction with either an AR model IF7000 RS-232 to Fiber-Optic Interface (1200 to 9600 baud only) or an AR model IF7001 USB to Fiber-Optic Interface (19200 baud only). Note that these devices use SMA connectors so a fiber-optic cable is needed with ST connectors on one end and SMA connectors on the other. This cable can be obtained from a fiber-optic cable distributor such as Fiber Instrument Sales (FIS). Their web-site can be found at www.fiberinstrumentsales.com. An example cable that will work for this connection is FIS Part Number D615M7FIS. The 7 in the part number refers to the length of the cable. In this case the length is 7 meters.

2.6.4 USB Communications

The USB port is a USB 2.0 port. It also complies with the USB Test and Measurement Class (USBTMC) Standard. Communications with this port requires the host computer to have a USBTMC driver available. All commands and queries through this port must be terminated with a Line Feed character.

The cable required to make this connection is a USB 2.0 A-B peripheral device cable. The cable can be no longer than 5 meters. If a longer distance is required a USB hub must be used. A cable carrying the official USB logo is recommended.

When connected to a PC running Windows 2000 or XP a window will pop-up labeled Hardware Wizard. If this PC has National Instruments LabView installed it will have a USBTMC driver that will work with this port. This driver will allow the device to be easily controlled using National Instruments Measurement and Automation Explorer or LabView. It should be noted that the USBTMC driver provided by National Instruments is a Virtual Instrument Software Architecture (VISA) driver which can be used with other programming languages besides LabView. For more information on this please consult the National Instruments Website found at www.ni.com.

NOTE: All firmware updates are done through the USB port.

2.6.5 Ethernet Communications

The Ethernet port allows remote control through a Transmission Control Protocol (TCP) data channel. All commands and queries through this port must be terminated with a Line Feed character.

By default this port is setup to work on a network with a Dynamic Host Configuration Protocol (DHCP) server. Upon connection, an Internet Protocol (IP) address is assigned based on the internal Media Access Control (MAC) address. The MAC address is printed on a label located near the Ethernet port.

If the connected network does not have DHCP enabled then the device can be assigned an IP address by the user. To do this, download the utility called DeviceInstaller™ from www.Lantronix.com. For assistance using this utility please consult the utilities embedded help file.

The DeviceInstaller™ utility will scan the network and find all connected Lantronix Ethernet devices. This list of found devices will include any connected AR Ethernet devices. By selecting one of the connected devices from the list, its IP address and subnet mask can be changed along with a number of other settings. One should use caution in adjusting any settings he/she is unfamiliar with as doing so may cause the port to become unresponsive. By default the port for the TCP data channel is 10001.

* DHCP (Dynamic Host Configuration Protocol) is a protocol used to assign a dynamic IP address to the unit. The network server software assigns an available IP address to the unit when the instrument is turned on. A different IP address may be assigned at different times.

2.6.6 Remote Commands

- If a command or query is unrecognized it is echoed back out the port it came in on.
- All commands and queries are terminated with a Line Feed character.
- A Line Feed character is indicated by <LF> in subsequent command and query definitions.
- All queries can be sent when the Keylock switch is in the INHIBIT, LOCAL, or REMOTE position.
- All commands can only be sent when the Keylock switch is in the REMOTE position.
- All spaces in command and query definitions are indicated by <space>.
- If a query is recognized, its associated response is echoed out the port it came in on.
- A **COMMUNICATIONS_ERROR<LF>** can occur if the time between commands or queries is too short, or the internal RS-485 link between the IO Board and the Control Board is broken.

The development of application programs requires an understanding of the operation of the amplifier as well as the intended application.

An application program on the computer/controller should issue only one character string (command or query) at a time. After each functional command is issued, the amplifier's status should be checked to ensure that the command has been properly executed. The application program should allow sufficient time for the function to be completed before checking the amplifier's status.

The application program should facilitate the checking of the amplifier's status just prior to issuing a command, since the status could have been changed by a fault condition or by operator actions.

Variables represented by wild card characters i.e. x, y, z etc. do not indicate or delimit the number of characters actually specified.

Table 2-4. Relationship between Amplifier Controls and Responses

X=NO, √=YES

AC POWER AND CIRCUIT BREAKER		POWER		KEYLOCK SWITCH			REMOTE COMMUNICATION	
ON	OFF	ON	OFF	INHIBIT	LOCAL	REMOTE	COMMAND	QUERY
	√						X	X
√			√			√	√	√
√		√				√	√	√
√		√			√		X	√
√		√		√			X	√
√			√		√		X	√
√			√	√			X	√

2.6.6.1 Power On/Off

This command controls the power on/off state of the amplifier.

Syntax: **POWER:x**

Parameters: State(x):
OFF = power off
ON = power on

Response Format: None (No query for this command)

Example: To turn the power on, send the following command: **POWER:ON<LF>**

To turn the power off, send the following command: **POWER:OFF<LF>**

2.6.6.2 RF On/Off

This command controls the RF on/off state of the amplifier.

Syntax: **RF:x**

Parameters: State(x):
OFF = power off
ON = power on

Response Format: None (No query for this command)

Example: To turn the RF on, send the following command: **RF:ON<LF>**

To turn the RF off, send the following command: **RF:OFF<LF>**

2.6.6.3 Reset Faults

This will clear all faults, if possible.

Syntax: **RESET**

Parameters: None

Response Format: None (No query for this command)

Example: To clear any faults, send the following command: **RESET<LF>**

2.6.6.4 Level Adjust

This command sets the RF Gain of the amplifier.

Syntax: **LEVEL:xy**

Parameters: Parameter(x):

GAIN = RF Gain

Value(y):

For RF Gain:

0 = Minimum

100 = Maximum

Response Format: None (No query for this command)

Example: To set the amplifier to minimum RF Gain, send the following command:
LEVEL:GAIN0<LF>

To set the amplifier to 50% RF Gain, send the following command:
LEVEL:GAIN50<LF>

2.6.6.5 Identity

Query to identify the amplifier:

Syntax: ***IDN?**

Parameters: None

Query only (always requires a ? character)

Response Format: **f,m,n,<LF>**

Where:

f = manufacturer

m = model designation

n = firmware revision

Example: To get the identity of the amplifier, send the following command:
***IDN?<LF>**

Response: **AR-RF/MICROWAVE-INST,350AH1A,1.0<LF>**

2.6.6.6 IO Board Firmware Revision

Query to get the firmware revision of the IO Board.

Syntax: ***IOB?**

Parameters: None

Query only (always requires a ? character)

Response Format: **INTERFACE_BOARD_SW_REVx<LF>**

Where:

x = firmware revision

Example: To get the firmware rev. of the IO Board, send the following command:
***IOB?<LF>**

Response: **INTERFACE_BOARD_SW_REV3.11<LF>**

2.6.6.7 State

Query to find the state of the amplifier.

Syntax: **STATE?**

Parameters: None

Response Format: **STATE=<space>xyza<LF>**

Where:

x, **y**, **z**, and **a** are each an ASCII character representing a hexadecimal character. They can be **0 to 9** or **A to F**.

Each hexadecimal character represents a 4-bit binary number. This 4-bit number is a bit pattern which contains information about the state of the amplifier. The definitions of these bit positions can be found in the table below.

NOTE: Bits labeled NOT USED may be read as a bit state of 1 or 0

	BIT POSITION	BIT DESCRIPTION	BIT STATE		NOTES:
			0	1	
x	0	(NOT USED)			
	1	(NOT USED)			
	2	(NOT USED)			
	3	REMOTE CONTROL	DISABLED	ENABLED	Response to key-switch position
y	0	POWER STATUS	OFF	POWER ON	
	1	STANDBY STATUS	OFF	STANDBY	Also known as RF OFF
	2	OPERATE STATUS	OFF	OPERATE	Also known as RF ON
	3	FAULT STATUS	OFF	FAULT EXISTS	
z	0	KEYLOCK INHIBIT	OFF	INHIBITED	Response to key-switch position
	1	(NOT USED)			
	2	(NOT USED)			
	3	(NOT USED)			
a	0	(NOT USED)			
	1	(NOT USED)			
	2	(NOT USED)			
	3	(NOT USED)			

Example: To read the state of the amplifier, send the following query: **STATE?<LF>**

Response: **STATE= <space>8100<LF>** (*Remote Mode and Power On*)

2.6.6.8 RMS Voltage

Query to get the RMS output voltage.

Syntax: **VRMS?**

Parameters: None

Response Format: **VRMS=x**

Where:

x = 0.0 to 99.9

Values are corrected and linearized. They can be up to four characters in length. Each response contains one decimal point that counts as one of the four characters. Units are Volts.

Example: To find out the RMS output voltage, send the following query: **VRMS?<LF>**

Response: **VRMS=11.3<LF>** (*11.3 Volts RMS*)

2.6.6.9 RMS Current

Query to get the RMS output current.

Syntax: **IRMS?**

Parameters: None

Response Format: **IRMS=x**

Where:

x = 0.0 to 99.9

Values are corrected and linearized. They can be up to four characters in length. Each response contains one decimal point that counts as one of the four characters. Units are Amperes.

Example: To find out the RMS output current, send the following query: **IRMS?<LF>**

Response: **IRMS=9.7<LF>** (9.7 Amperes RMS)

2.6.6.10 RMS Power

Query to get the RMS output power.

Syntax: **PWR?**

Parameters: None

Response Format: **PWR=x**

Where:

x = 0.0 to 999.9

Values are corrected and linearized. They can be up to five characters in length. Each response contains one decimal point that counts as one of the five characters. Units are Volt-Amps (VA).

Example: To find out the RMS output power, send the following query: **PWR?<LF>**

Response: **PWR=148.6<LF>** (148.6 VA RMS)

2.6.6.11 RF Gain

Query to get the RF gain.

Syntax: **RFG?**

Parameters: None

Response Format: **RFG=<space>x**

Where:

x = 0000 to 0100

Example: To find out the RF gain of the amplifier, send the following query: **RFG?<LF>**

Response: **RFG=<space> 0075<LF>** (75% Gain)

2.6.6.12 Output Phase Selection

Command/query to set and/or get the output phase with respect to the input.

Syntax: **PHASEx**

Parameters: **Value(x):**

0 = Output phase is the same as input signal

180 = Output phase is 180° out of phase from input signal

Syntax: **PHASE?**

Response Format: **PHASE=x**

Where:

x = 0 or 180

Example: To find out the output phase, send the following query: **PHASE?<LF>**

Response: **PHASE=0<LF>**

2.6.6.13 Output Measurement Display Mode

Command to set the format used to display output measurements.

Syntax: **DISP:x**

Parameters: **Mode(x):**

IVR = display RMS Voltage and RMS Current

PWR = display RMS Power

Response Format: None (No query for this command)

Example: To display the RMS output voltage and RMS output current, send the following command: **DISP:IVR<LF>**

To display the RMS output power, send the following command: **DISP:PWR<LF>**

2.6.6.14 Faults

Query to find the faults that have occurred with the amplifier.

Syntax: **FSTA?**

Parameters: None

Response Format: **FSTA=<space>xxxx<LF>**

Where:

xxxx = **0000** to **001A** (Hexadecimal)

Dec	xxxx	Fault Text	Description	RF State After Fault Reset
0	0000	N/A	No fault	N/A
1	0001	AC Interlock	AC Interlock	Off
4	0004	Interlock	Interlock	Off
5	0005	PS2	Power Supply 2	Off
22	0016	Thermal Fault	Thermal	Off
26	001A	ALC	ALC Fault	Off

Example: To find out what faults have occurred, send the following query: **FSTA?<LF>**

Response: **FSTA= 0004<LF>** (*Interlock Fault*)

3. THEORY OF OPERATION

3.1 GENERAL

The Model 350AH1A amplifier can be a relatively simple unit to understand. The amplifier is a straightforward design, with a few control elements in the lineup. The unit's power supply, control and fault detection circuits can be easily understood by anyone with a minimal understanding of analog and digital circuitry.

3.2 AMPLIFIER

Refer to Interconnect Diagram 10036272 and the schematics referred to below.

3.2.1 Amplifier RF Input

From the RF input, the signal path is as follows. From the Type BNC connector on the control panel, the signal travels to the variable gain amp assembly.

3.2.2 Variable Gain Amp

Refer to Schematic 10043102. The variable gain amplifier is a broadband IC with a voltage-controlled gain feature. It is powered by $\pm 5\text{VDC}$.

3.2.3 350W Module

Refer to Schematic 10024788. This module is a Class AB amplifier which uses a driver section and eight pairs of lateral power MOSFETs as power output devices. Both N channel and P channel devices are used.

The driver circuit is comprised of an operational amplifier stage and a Class AB amplifier stage using two transistors to obtain the amplitude and power level in order to drive the output devices as a follower circuit.

3.3 POWER SUPPLY

Refer to Schematic Diagram Number 10024922, **Interconnect Diagram, 350AH1A**. Main power to the unit is supplied by single phase AC power within the proper range. In series with the line voltage is the 20A **Main circuit breaker CB1**, located on the rear panel. This circuit breaker supplies line voltage to the contactor located just behind the rear panel. The contactor is controlled by the front panel Power ON/Off switch and interrupted manually by the three-position key-switch labeled **Inhibit – Local – Remote**. The contactor feeds AC directly to the primary inputs of the main power supplies. When the main circuit breaker is on, AC power is fed to the low voltage supply, PS1. Therefore, when the circuit breaker is turned on, the control panel and basic low-power supplies are alive, and the amplifier is armed for Power On. At this time, the front panel display is illuminated and the control circuitry is active.

The high-power supply PS2 provides input and output TTL-compatible logic signals for inhibiting the supply and signaling the control system that the supply is malfunctioning. The fault signal is normally HI, going LO when a fault is present. The Enable signal must be LO to enable and either HI or Open to inhibit the output.

3.4 CONTROL CIRCUITS

3.4.1 Power On/Operate Circuits

This section describes the functioning of the switches, relays and controls in the AC/DC power distribution system. See Schematic Drawing Number 10024922, **Interconnect Diagram, 350AH1A**.

Circuit breaker CB1 disconnects all circuits from the AC mains. Assume that circuit breaker CB1 is closed. +5VDC and +/-15VDC are connected to the DCP and ALC board.

If the Keylock Switch is in the LOCAL position, when the POWER switch is energized, then +15VDC will be applied to the Power On relay, K1. Note that in order to complete the circuit through K1, the external AC interlock circuit must be closed. The rear panel Safety Interlock connector provides pins 10 and 14 for this purpose. Another interlock circuit, provided in the same connector, is used for RF inhibit, pins 1 and 8, if the user so desires. Both types can be used simultaneously in their respective circuits. If the AC interlock circuit is open, a direct logic signal will be applied to the Control Panel to display **ACINT** on the display when Power On is attempted. If the Inhibit interlock is open, **INT** will be displayed.

The energized relay K1 will apply the AC mains to the main power supplies. The amplifier will then be in the STANDBY condition. In this state, all high level RF stages are without DC power, making it impossible to produce any RF power in the amplifier. Cooling fans will be heard even though no DC is output from the main power supplies. The main power supplies will be armed for DC Enable and waiting for Operate mode to be executed.

If the RF ON button is pressed, and there are no interlock faults existing, the power supply inhibit signal is removed, allowing high level amplifiers to become functional. After a short delay for circuit stabilization, all Fault signals are monitored; if there are no faults then the amplifier will continue to function normally.

If the Keylock Switch is in the REMOTE position, the Power and RF ON functions are the same except that they can only be performed remotely (i.e., from the user's computer), since the front panel controls are locked out when the amplifier is in the Remote mode.

3.4.2 A13 ALC Board (Schematic #10023927)

This section describes the operation of the level control board. The level control board performs the following functions:

- Provides automatic level control of the amplifier's output when the amplifier is placed in the ALC mode.
- Limits RF input level to the amplifier when forward or reflected power levels exceed specified levels.
- Drives forward and reflected indicators on the front panel display.

3.5 FAULT DETECTION CIRCUITS

This section describes the function and theory of the Model 350AH1A's fault detection circuits. All fault-signalling circuits are wired directly to the control panel for processing.

Detected fault signals are recorded in temporary (volatile) memory before the amplifier control circuits act to protect the amplifier, sometimes resulting in RF inhibit or shut down. In some cases, inputs are read multiple times to prevent a transient signal from causing an unwarranted action. Note that after a fault condition has been invoked, the circuit breaker CBI must be left on to keep the temporary memory active, so that all faults can be manually recorded for diagnostic purposes. Faults may be recorded by the host system if the host software is written to respond to fault conditions. Fault conditions may be queried at any time during normal operation of the amplifier. When there are multiple faults, the display can be scrolled to view all of them.

3.5.1 Thermal Faults

The 350AH1A output module contains a thermal sensor switch. In the case of a thermal fault, the line will go high. The control panel displays **TH**, and the main power supply will be inhibited to allow the module to cool down.

3.5.2 Power Supply Faults

The main power supply is monitored internally. If the supply fails to produce DC voltage within its specification, a logic signal will signal the fault board, resulting in an amplifier shut down. The power supply faults and inhibit signals are routed to the Control Panel. The fault signal is a logic high (+5VDC) when all is well, switching to a logic low if a fault occurs.

3.5.3 ALC Fault

An ALC fault is invoked whenever the DC and output current limit controls do not function, causing the RF power to exceed one of the preset limits. The ALC fault is a logic low when invoked. The logic low from the ALC board signals the digital control panel, which, in turn, disables the RF output by inhibiting the driver.

3.5.4 Interlocks

The Model 350AH1A has two interlocks that are wired to the rear panel Safety Interlock connector. The interlocks are separate circuits, with different actions taken when invoked. Both interlocks require normally closed external circuits to allow the amplifier to function.

3.5.4.1 Inhibit Interlock

For interlock applications where the amplifier is not required to shut down totally (AC Off), this interlock circuit inhibits RF amplification by disabling the low level amplifier stages and forcing the amplifier into the Standby condition. The inhibit interlock is wired to the rear panel Interlock connector pins 1 and 8. A closed circuit from Interlock connector pin 1 to pin 8 is required for normal operation. Opening the connection will inhibit the amplifier and display **INT** on the front panel. When the inhibit interlock has been opened, the amplifier returns to the Standby condition, forcing the re-assertion of the RF ON command to return to normal operation.

3.5.4.2 AC Interlock

For interlock applications that are more safety critical, where logic circuits are not trusted, the **AC interlock** can be used to disconnect the amplifier from the AC mains. This interlock circuit is connected directly in series with the AC relay circuit. There are no logic circuits or transistors in this signal path. Rear panel Interlock connector Pins 10 and 14 are for this purpose. Pin 10 must be brought low to energize K1, Pin 14 goes low when the power switch is activated. Opening the AC interlock connection will disconnect AC primary power to all major circuits and display **AC INT** on the front panel.

The fault conditions can be reset by pressing the **RESET** switch on the front panel (when the Keylock Switch is set to **LOCAL**) or by a command sent from the user's computer (when the Keylock Switch is set to **REMOTE**). Either of these conditions causes the amplifier to return to normal conditions, when the RF ON command can be asserted. The forcing of the RF ON command after a fault or interlock condition is a safety feature that prevents an unexpected burst of RF when the fault or interlock condition has been restored. Fault conditions that require the amplifier to be disconnected from the AC mains will be reset automatically upon re-energizing the amplifier. Only fault conditions that continue to be valid will be displayed after the AC mains have been disconnect via the circuit breaker or external disconnection.

4. TROUBLESHOOTING AND REPAIR

4.1. GENERAL

Because it is a relatively simple instrument, the Model 350AH1A should require very little maintenance. It is built with solid state devices and printed wiring boards (PWBs) that should ensure long, trouble-free life. Should trouble occur, special care must be taken when servicing the unit to avoid damaging the solid-state devices and PWBs.

Since the amplifier's components are soldered in place, substitution of components should not be resorted to unless there is some indication that they are faulty. In addition, care must be taken not to short voltages across the amplifier when troubleshooting, because small bias changes may damage the amplifier due to excessive dissipation or transients.

Components used in Amplifier Research instruments are conservatively operated to provide maximum instrument reliability. In spite of this, parts may fail. Usually, the instrument must be immediately repaired with a minimum of down time. A systematic approach can greatly simplify and thereby speed up repairs. The Model 350AH1A incorporates fault control and detection circuits, including display panel indications that can expedite troubleshooting of the unit. For a description of how these indications can be used to assist in troubleshooting the unit, please see section 4.2, **Fault Signal Interpretation and Diagnosis**.

Shipping instructions are as follows:

To return an item, contact AR Customer Service for an RMA number and shipping instructions. Returns from outside the United States are not permitted without prior authorization. If shipping from outside of the United States, closely follow all directions on the RMA form for return shipping and marking. See warranty statement at rear of manual.

4.2 FAULT SIGNAL INTERPRETATION AND DIAGNOSIS



CAUTION:

Extreme caution should be exercised when troubleshooting this unit, particularly when measuring voltages in the power supply section, as hazardous voltages exist in the unit that could cause serious injury to personnel performing such measurements.

4.2.1 General - Reading faults

The Model 350AH1A incorporates relatively simple fault detection circuitry, which makes use of the digital display panel to alert the user or technician which component(s) need service. Use of these indications can usually expedite troubleshooting of the amplifier. Most faults can be immediately determined down to the assembly level. If a reset is still indicated, turn off the RF power signal to the input of the amplifier, read and record the fault indication displayed on the digital control panel for later reference. Then, use the RESET function to see if the fault clears. If the fault clears, slowly bring the amplifier's drive level back up and ensure that recommended RF power levels are not exceeded. If the fault indication is no longer visible, the fault may have been brought about by a temporary transient condition, component thermal condition or excessive RF drive to the amplifier's input. If the fault does not clear with the RF drive off, some other problem exists in the amplifier.

4.2.2 Power Supply Fault

Indication – PS2

The main power supply has failed to produce DC voltage within the design range of the power supply. The main power supply is located on the bottom shelf of the amplifier.

4.2.3 Thermal Faults

Only RF module thermal faults are detected. See Section 4.3.

4.2.4 ALC Fault

Indication – ALC

As stated previously, the power limit controls could not limit either the DC and output current to the preset threshold. This can be a transient type of problem, if the fault can be cleared. If the fault cannot be cleared with no RF input drive power, then there is a malfunction in the ALC board or associated circuit.

WARRANTIES: LIMITATION OF LIABILITY

Seller warrants (i) that seller has title to the goods sold and (ii) that Amplifiers (all parts excluding traveling wave and vacuum tubes), Antennas, field monitors, field probes, field analyzers, field analyzer processor units, system controllers, system interlock, power meters, leak detectors, RF conducted probes, RF conducted clamps, Multi-tone, EMI receiver systems, RF down converters, RF conducted immunity systems, conducted immunity accessories, radiated immunity test systems, safety meters, safety sensor heads, tripods, directional couplers, waveguide adapters, termination loads, load attenuators, impedance stabilization networks, and coaxial cables will be free from defects in material and workmanship for a period of three (3) years from date of shipment shown on AR RF/Microwave Instrumentation invoice.

All modules, used in the amplifiers for the 1-6 GHz, 4-18 GHz, 6-18 GHz, all HPM products, and other applications, are hermetically-sealed. This sealing process protects the internal hybrid circuitry from humidity that could compromise the long term reliability of the product. These modules are not field-repairable and should *never* be opened outside of AR's Microelectronics Lab. The modules in these product lines have a security label on two sides of the modules between the housing and lid/cover. If the security label is removed and or cut, the warranty of the module will be voided.

Vacuum tubes in the 'L' series amplifiers, traveling-wave tubes in TWT amplifiers, and power heads will be free from defects in material and workmanship for a period of one (1) year.

Contact AR RF/Microwave Instrumentation for warranty information regarding items not listed.

Seller's sole responsibility in fulfilling these warranties shall be to repair or replace any goods which do not conform to the foregoing warranties or, at seller's option, to give buyer credit for defective goods. The warranty is valid only when used in the country specified at time of order. Warranty service must be obtained from the repair facility designated at that time. If warranty service is not available in the country where the equipment is to be used, it must be returned to AR RF/Microwave Instrumentation. Warranty service will be provided only for defective goods which are returned within the warranty period, freight costs prepaid to AR RF/Microwave Instrumentation or its designated repair facility.

There are no other warranties, express or implied, including any warranty of merchantability or fitness. Seller shall not be responsible for any incidental or consequential damages arising from any breach of warranty.

No person other than an officer of Amplifier Research Corporation, has any authority to bind seller to any affirmation, representation or warranty except as specifically included in the preceding terms and conditions.

