



rf/microwave instrumentation

Operating and Service Manual

20S6G18A-L

Model

10050714

Part Number

Serial Number



Declaration of Conformity

Issue Date: October 2020
Model #/s: Model 20S6G18A-L Series
Type of Equipment: RF Broadband Amplifier
Function: Designed to be used in a RF immunity test system or for research. The unit is intended to amplify an RF signal and inject it into a load.

The equipment described above is declared to be in conformity with the following applicable national and international standards. The conformity is valid only when equipment is used in a manner consistent with the manufacturer’s recommendations and the reference documents.

EMC:
DIRECTIVE 2014/30/EU of the European Parliament and of the Council of 26 February 2014 on the harmonisation of the laws of the Member States relating to electromagnetic compatibility
EN 61326-1:2013 Electrical equipment for measurement, control and laboratory use–EMC requirements–Part 1: General Requirements
SAFETY:
DIRECTIVE 2014/35/EU of the European Parliament and of the Council of 26 February 2014 on the harmonisation of the laws of the Member States relating to the making available on the market of electrical equipment designed for use within certain voltage limits
CENELEC EN 61010-1 Issued 2010/10/01 Ed: 3 Safety Requirements for Electrical Equipment for Measurement Control and Laboratory Use – Part 1: General Requirements
UL 61010-1 Issued 2012/05/11 Ed: 3 Safety Requirements for Electrical Equipment for Measurement Control and Laboratory Use – Part 1: General Requirements
CAN/CSA C22.2 #61010-1 Issued 2012/05/11 Ed: 3 Safety Requirements for Electrical Equipment for Measurement Control and Laboratory Use – Part 1: General Requirements
HAZARDOUS SUBSTANCES (RoHS):
DIRECTIVE 2011/65/EU of the European Parliament and of the Council of 8 June 2011 on the restriction of the use of certain hazardous substances in electrical and electronic equipment (recast) Commission Delegated Directive (EU) 2015/863 of 31 March 2015 amending Annex II to Directive 2011/65/EU of the European Parliament and of the Council as regards the list of restricted substances Directive (EU) 2017/2102 of the European Parliament and of the Council of 15 November 2017 amending Directive 2011/65/EU on the restriction of the use of certain hazardous substances in electrical and electronic equipment
RECYCLING (WEEE):
DIRECTIVE 2012/19/EU of the European Parliament and of the Council of 4 July 2012 on waste electrical and electronic equipment (WEEE) (recast)
SUBSTANCES OF VERY HIGH CONCERN (REACH):
REGULATION (EC) 1907/2006 of the European Parliament and of the Council of 18 December 2006 concerning the Registration, Evaluation, Authorization and Restriction of Substances of Very High Concern Chemicals (SVHC)

Supporting documentation is held by AR RF/Microwave Instrumentation’s Quality department in Pennsylvania, United States.

Place of issue: AR RF/Microwave Instrumentation
160 Schoolhouse Road
Souderton, Pennsylvania 18964 USA

Authorized officer of the company:

Patricia Thrasher
Manager Quality & Service

Instructions for European EMC Conformity



It is the responsibility of the user of this equipment to provide electromagnetic shielding, filtering and isolation which is necessary for EMC compliance to Directive 2014/30/EU. The equipment must therefore be operated in a shielded area which provides a sufficient level of attenuation to meet the radiated emissions and immunity specifications. The following minimum levels are suggested for use in accordance with the rated power of the equipment.

Rated Power	Minimum shielding attenuation
100 watts	50 dB
101 - 1000 watts	60 dB
1001 - 10,000 watts	70 dB

Since this equipment is designed to generate high levels of Radio Frequency energy, it is also essential that the user read and follow the “Instructions for Safe Operation” in this manual. If other equipment is operated in the shielded room it may be disturbed by the amplifier.



Der Benutzer dieses Gerätes ist dafür verantwortlich, daß die elektromagnetische Abschirmung und Filterung gewährleistet ist, welche gemäß Richtlinie 2014/30/EU notwendig ist. Das Gerät muß deshalb in einem geschirmten Raum betrieben werden, welcher eine ausreichenden Schirmung bietet, um die Emissions- und Störfestigkeitsspezifikation einzuhalten. Es werden folgenden Minimalwerte der Schirmdämpfung und Filterung in den unterschiedlichen Leistungsklassen empfohlen.

Hochfrequenzleistung	min. Schirmdämpfung
100 Watt	50 dB
101-1000 Watt	60 dB
1001-10.000 Watt	70 dB

Falls andere elektrische oder elektronische Geräte gleichzeitig mit dem Gerät betrieben werden, kann es zu Beeinflussungen kommen. Da das Gerät zur Erzeugung von Hochfrequenzenergie dient ist es daher auch unbedingt notwendig, daß der Benutzer die Sicherheitsvorschriften in der Bedienungsanleitung liest und einhält.



Il est de la responsabilité de l'utilisateur de cet équipement d'assurer la protection électromagnétique, le filtrage et l'isolation nécessaires, afin de se conformer à la directive 2014/30/EU concernant la C.E.M. Par conséquent, cet équipement doit être mis en fonctionnement dans une enceinte d'atténuation suffisante pour satisfaire aux spécifications d'émissivité et de susceptibilité. Pour une utilisation conforme, les niveaux d'atténuation minimums suivants sont suggérés en fonction de la puissance de sortie de l'équipement:

Puissance de sortie	Atténuation minimum de l'enceinte
100 Watts	50 dB
101 à 1.000 Watts	60 dB
1.001 à 10.000 Watts	70 dB

Puisque cet équipement est destiné à générer de forts niveaux R.F., il est essentiel que l'utilisateur se conforme aux instructions de sécurité indiquées dans ce manuel. Tout autre équipement en fonctionnement dans la cage de Faraday peut-être perturbé par l'amplificateur.

INSTRUCTIONS FOR SAFE OPERATION

Observe the following safety guidelines to help ensure your own personal safety and to help protect your equipment and working environment from potential damage.

INTENDED USE

This equipment is intended for general laboratory use in generating, controlling, and measuring levels of electromagnetic Radio Frequency (RF) energy. Ensure that the device is operated in a location which will control the radiated energy and will not cause injury or violate regulatory levels of electromagnetic interference.

SAFETY SYMBOLS

These symbols may appear in your user manual or on equipment.

	This symbol is marked on the equipment when it is necessary for the user to refer to the manual for important safety information. The caution symbol denotes a potential hazard. Attention must be given to the statement to prevent damage, destruction, or harm.
	Dangerous voltages are present. Use extreme care.
	Indicates a terminal intended for connection to an external conductor for protection against electrical shock in case of a fault, or the terminal of a protective earth (ground) electrode.
	Indicates invisible laser radiation—do not view directly with optical instruments.
	Indicates frame or chassis ground connection terminal.
	Indicates alternating current.
	Indicates this product must not be disposed of with your other household waste.
	Indicates that the marked surface and adjacent surfaces can attain temperatures that may be hot to the touch.

EQUIPMENT SETUP PRECAUTIONS



Review the user manual and become familiar with all safety markings and instructions. Protection provided by the equipment may be impaired if used in a manner not specified by AR RF/Microwave Instrumentation (AR).

- Follow all lifting instructions specified in this document.
- Place the equipment on a hard, level surface.
- Do not use the equipment in a wet environment, for example, near a sink, or in a wet basement.
- Position your equipment so that the power switch is easily accessible.
- Leave 10.2 cm (4 in) minimum of clearance on all vented sides of the equipment to permit the airflow required for proper ventilation. Do not restrict airflow into the equipment by blocking

any vents or air intakes. Restricting airflow can result in damage to the equipment, intermittent shut-downs or safety hazards.

- Keep equipment away from extremely hot or cold temperatures to ensure that it is used within the specified operating range.
- While installing accessories such as antennas, directional couplers and field probes, take care to avoid any exposure to hazardous RF levels.
- Ensure that nothing rests on your equipment's cables and that the cables are not located where they can be stepped on or tripped over.
- Move equipment with care; ensure that all casters and/or cables are firmly connected to the system. Avoid sudden stops and uneven surfaces.

BEFORE APPLYING POWER

Your AR equipment may have more than one power supply cable. Use only approved power cable(s). If you have not been provided with a power cable for the equipment or for any AC-powered option intended for the equipment, purchase a power cable that is approved for use in your country. The power cable must be rated for the equipment and for the voltage and current marked on the equipment's electrical ratings label.



Incorrectly installing or using an incompatible line voltage may increase the risk of fire or other hazards. To help prevent electric shock, plug the equipment and peripheral power cables into properly grounded electrical outlets. These cables are equipped with three-prong plugs to help ensure proper grounding. Do not use adapter plugs or remove the grounding prong from a cable.

Do not modify power cables or plugs. Consult a licensed electrician or AR trained service technician for equipment modifications. Always follow your local/national wiring rules.



Do not operate the equipment if there is physical damage, missing hardware, or missing panels.

SAFETY GROUND



This equipment is provided with a protective earth terminal. The mains power source to the equipment must supply an uninterrupted safety ground of sufficient size to attach wiring terminals, power cord, or supplied power cord set. ***DO NOT USE this equipment if this protection is impaired.***

INSTRUCTIONS FOR SAFE OPERATION

HAZARDOUS RF VOLTAGES



The RF voltages on the center pin of an RF output connector can be hazardous. The RF output connector should be connected to a load before AC power is applied to the equipment. Do not come into contact with the center pin of the RF output connector or accessories connected to it. Place the equipment in a non-operating condition before disconnecting or connecting the load to the RF output connector.

ACOUSTIC LIMITATIONS

If equipment noise exceeds 80dB, ear protection is required.

MAINTENANCE CAUTION

Adjustment, maintenance, or repair of the equipment must be performed only by qualified personnel. Hazardous energy may be present while protective covers are removed from the equipment even if disconnected from the power source. Contact may result in personal injury. Replacement fuses are required to be of specific type and current rating.

ENVIRONMENTAL CONDITIONS

Unless otherwise stated on the product specification sheet, this equipment is designed to be safe under the following environmental conditions:

- Indoor use
- Altitude up to 2000m
- Temperature of 5°C to 40°C
- Maximum relative humidity 80% for temperatures up to 31°C. Decreasing linearly to 50% at 40°C.
- Main supply voltage fluctuations not to exceed $\pm 10\%$ of the nominal voltage or minimum and maximum autoranging values.
- Pollution degree 2: Normally non-conductive with occasional condensation. While the equipment will not cause hazardous condition over this environmental range, its performance may vary.

EQUIPMENT CONTAINING LASERS



AR Field Probes (FL/PL Series) and Field Analyzers (FA Series) are Class 1 laser products containing embedded Class 4 lasers. Under normal use, the laser radiation is completely contained within the fiber optic cables and poses no threat of exposure. Safety interlocks ensure that the laser is not activated unless the cables are properly connected. Always exercise caution when using or maintaining laser products. Do not view directly with optical instruments.

RF ANTENNAS

- This equipment (antenna or antenna assembly) may be heavy, requiring two persons to lift. Use caution when installing or removing unit. Follow all equipment setup and lifting instructions specified in this document.
- Ensure connectors are appropriate for intended operation. Connectors are specified in the user manual and product specification sheet.
- Do not exceed the maximum RF input level stated in the specifications. Refer to the user manual and product specification sheet to determine the applicable RF levels.
- Excessive RF input could damage the equipment or connectors, causing safety hazards.
- When in operation, the RF voltages on the antenna elements can be hazardous. Do not come into contact with the antenna or elements when the RF input connector is connected to a live RF source.
- To avoid injury to personnel and accidental damage to power amplifier or antenna, disable the RF output of power amplifier before connecting or disconnecting the input connection to the antenna.
- Perform periodic inspections of antenna and field probe systems to verify calibration due date, proper operation, and overall condition of equipment.

RACK MOUNTED TWT MODELS

Some TWT models are supplied without the removable enclosure offered for benchtop use. These rack-mountable models may be supplied with either carry handles or slides and front handles installed. Follow all lifting instructions specified in this document and installation instructions supplied in the TWT user manual.

LIFTING INSTRUCTIONS FOR AR EQUIPMENT

Because most products must be handled during distribution, assembly and use, the risk of serious injury due to unsafe product handling should be a fundamental consideration of every user. An authoritative guideline for eliminating unwarranted risk of injury caused by lifting is provided by the NIOSH Work Practices (Publication #94-110) available at:



<https://www.cdc.gov/niosh/docs/94-110/pdfs/94-110.pdf>.

In general, observe the following guidelines for lifting a weight of 50 lb or more:

- Use lifting eye (for floor standing) or side handles (table top) to lift unit only.
- Use equipment of adequate capacity to lift and support unit.
- If using forklift to move unit, be sure forks are long enough to extend beyond the side of the unit.
- For additional information, follow the link specified above.

HINWEISE FÜR DEN SICHEREN GEBRAUCH









Bitte beachten Sie die folgenden Hinweise zum Schutz Ihrer persönlichen Sicherheit und um Ihre Ausrüstung und Ihren Arbeitsplatz vor möglichen Schäden zu bewahren.

VORGESEHENE VERWENDUNG

Dieses Gerät ist für den allgemeinen Einsatz im Labor bestimmt. Es dient der Erzeugung, Steuerung und Messung von elektromagnetischer Hochfrequenzenergie (RF). Stellen Sie sicher, dass das Gerät an einem Ort in Betrieb genommen wird, an dem die abgestrahlte Energie gesteuert werden kann, so dass niemand Schaden erfährt und elektromagnetische Störungen vermieden werden.

SICHERHEITSSYMBOL

Einige dieser Symbole befinden sich sowohl in der Bedienungsanleitung als auch auf dem Gerät selbst.

	Dieses Symbol befindet sich auf dem Gerät und weist darauf hin, dass der Nutzer an dieser Stelle wichtige Sicherheitsinformationen in der Bedienungsanleitung studieren soll. Das Warnsymbol weist auf eine mögliche Gefahr hin. Zur Vermeidung von Personen- oder Sachschäden gilt es, die Hinweise zu beachten.
	Gefährliche elektrische Spannungen sind vorhanden. Höchste Vorsicht ist geboten.
	Weist darauf hin, dass an dieser Stelle eine Klemme für den Anschluss an einen Außenleiter anzubringen ist, zum Schutz vor einem Stromschlag oder im Fall einer auftretenden Störung, oder dass eine Klemme anzubringen ist, die als schützende Erdungselektrode fungiert.
	Zeigt unsichtbare Laserstrahlung an – nicht direkt hineinschauen.
	Weist auf eine Rahmen- oder Chassis-Anschlussklemme hin.
	Zeigt Wechselstrom an.
	Weist darauf hin, dass dieses Produkt nicht mit Ihrem restlichen Hausmüll entsorgt werden darf.
	Weist darauf hin, dass die markierte Oberfläche und benachbarte Flächen extrem heiße Temperaturen erreichen können und daher nicht angefasst werden sollten.

SICHERHEITSHINWEISE FÜR DEN AUFBAU DES GERÄTS



Lesen Sie die Bedienungsanleitung aufmerksam durch und machen Sie sich mit allen Sicherheitsmarkierungen und Anweisungen vertraut. Die Sicherheit kann beeinträchtigt sein, falls das Gerät in einer anderen Weise verwendet wird, als von der AR RF/Microwave Instrumentation (AR) vorgegeben ist.

- Zum Heben und Transport folgen Sie allen in dieser Anleitung angegebenen Anweisungen.
- Platzieren Sie das Gerät auf einer harten, ebenen Oberfläche.
- Verwenden Sie das Gerät nicht in feuchter Umgebung, zum Beispiel in der Nähe einer Spüle oder in einem feuchten Keller.
- Platzieren Sie Ihr Gerät so, dass der Netzschalter leicht zugänglich ist.

- Halten Sie einen Mindestabstand von 10,2 cm (4 in) auf allen belüfteten Seiten des Geräts ein, um eine ausreichende Luftzirkulation zu gewährleisten. Beeinträchtigen Sie den Luftstrom des Geräts nicht, indem Sie Lüftungsöffnungen oder den Lufteinlass blockieren. Wird der Luftstrom eingeschränkt, kann dies zu Schäden am Gerät, periodischen Abschaltungen und anderen Gefahren führen.
- Halten Sie das Gerät von extrem heißen oder kalten Temperaturen fern, um sicherzustellen, dass es nur in dem vorgeschriebenen Bedienungsbereich verwendet wird.
- Achten Sie beim Installieren von Zubehör wie Antennen, Richtungskupplungen und Feldsonden darauf, dass sie keinen gefährlichen HF-Werten ausgesetzt sind.
- Stellen Sie sicher, dass nichts auf den Kabeln Ihres Geräts steht. Bringen Sie die Kabel so an, dass niemand darauf treten oder darüber stolpern kann.
- Seien Sie vorsichtig, wenn Sie das Gerät bewegen. Achten Sie darauf, dass alle Rollen und/oder Kabel fest mit dem System verbunden sind. Vermeiden Sie plötzliche Stopps und Oberflächen, die nicht eben sind.

BEVOR SIE DAS GERÄT ANSCHLIESSEN

Ihre AR-Ausrüstung hat möglicherweise mehr als ein Stromversorgungskabel. Verwenden Sie nur zugelassene Stromkabel. Falls Sie kein Stromkabel oder AC-Netzkabel für dieses Gerät haben, kaufen Sie ein Stromkabel, das für den Einsatz in Ihrem Land zugelassen ist. Das Stromkabel muss für das Gerät, die Spannung und den Strom, die auf dem elektrischen Kennzeichnungsetikett des Geräts markiert sind, zugelassen sein.



Bei einer fehlerhaften Installation oder falls eine Netzspannung verwendet wird, die nicht mit dem Gerät kompatibel ist, erhöht sich die Brandgefahr. Auch andere Gefahren können auftreten. Um einen Stromschlag zu verhindern, schließen Sie das Gerät und die peripheren Stromkabel an ordnungsgemäß geerdete Steckdosen an. Die Kabel sind mit dreipoligen Steckern ausgestattet, um eine korrekte Erdung zu gewährleisten. Verwenden Sie keine Adapter. Entfernen Sie niemals die Erdungsstange eines Kabels.

Modifizieren Sie niemals die Stromkabel oder Stecker. Konsultieren Sie einen lizenzierten Elektriker oder AR-ausgebildeten Servicetechniker, falls Veränderungen am Gerät durchgeführt werden müssen. Halten Sie sich stets an die nationalen/örtlichen Verdrahtungsregeln.



Schalten Sie das Gerät nicht ein, falls es äußerlich beschädigt ist oder Hardware-Teile oder Konsolen fehlen.

SYSTEMERDUNG



Dieses Gerät ist mit einer Schutzerdklemme ausgestattet. Die Netzstromquelle muss dem Gerät eine ununterbrochene Systemerdung von ausreichender Größe zur Verfügung stellen, damit Kabelklemmen, Netzkabel oder mitgeliefertes Netzkabel ordentlich befestigt werden können. **VERWENDEN SIE DIESES GERÄT NICHT, wenn dieser Schutz beeinträchtigt ist.**

HINWEISE FÜR DEN SICHEREN GEBRAUCH

GEFÄHRLICHE HF-SPANNUNGEN



Die HF-Spannungen am mittleren Pin eines HF-Ausgangsanschlusses können gefährlich sein. Der HF-Ausgangsanschluss sollte an eine Last angeschlossen werden, bevor das Gerät ans Stromnetz angeschlossen wird. Kommen Sie nicht mit dem Mittelstift des HF-Ausgangsanschlusses oder dem damit verbundenen Zubehör in Kontakt. Bevor Sie die Last vom HF-Ausgang trennen oder diese anschließen, stellen Sie das Gerät in einen nicht betriebsfähigen Zustand.

HÖRSCHUTZ

Sollten die Geräusche, die das Gerät verursacht, 80dB überschreiten, ist Gehörschutz erforderlich.

WARTUNGSHINWEISE

Einstellung, Wartung oder Reparaturen der Ausrüstung dürfen nur von qualifizierten Fachleuten durchgeführt werden. Gefährliche Spannungen können auftreten, wenn Schutzabdeckungen vom Gerät entfernt werden, auch wenn es nicht an die Stromquelle angeschlossen ist. Kontakt kann zu Verletzungen führen. Es können nur bestimmte Ersatzsicherungen mit speziellem Nennstrom verwendet werden.

UMGEBUNGSBEDINGUNGEN

Sofern auf dem Produktspezifikations-Blatt nichts anderes angegeben ist, ist dieses Gerät unter folgenden Bedingungen sicher einsetzbar:

- Gebrauch in Innenräumen
- Höhe bis zu 2000m
- Temperaturen von 5°C bis 40°C
- Maximale relative Luftfeuchtigkeit 80% bei Temperaturen bis 31°C. Lineare Abnahme auf 50% bei 40°C.
- Netzspannungsschwankungen sollen nicht mehr als $\pm 10\%$ der Nennspannung oder der minimal und maximal eingestellten Werte betragen.
- Verschmutzungsgrad 2: Normalerweise nichtleitfähige Verschmutzung mit gelegentlicher Kondensation. Das Gerät wird bei Einsatz in diesem Bereich keine Gefahr verursachen, die Leistung kann dennoch variieren.

LASER-INFORMATION



AR - Feldsonden (FL/PL-Serie) und Feldanalysatoren (FA-Serie) sind Laserprodukte der Klasse 1 mit eingebetteten Klasse-4-Lasern. Bei normalem Gebrauch kann der Laserstrahlung nicht aus den Glasfaserkabel herausdringen. Sicherheitsverriegelungen sorgen dafür, dass der Laser nur aktiviert wird, wenn die Kabel richtig angeschlossen sind. Lassen Sie stets Vorsicht walten bei der Verwendung oder Wartung von Laserprodukten. Niemals direkt hineinschauen.

HF-ANTENNEN

- Die Ausrüstung (Antenne oder Antennenmontage) ist mitunter schwer. Die Montage erfordert daher oft zwei Personen. Folgen Sie allen in diesem Dokument angegebenen Anweisungen zur Anbringung.
- Stellen Sie sicher, dass alle Anschlüsse für den beabsichtigten Betrieb geeignet sind. Informationen zu den Anschlüssen erhalten Sie im Benutzerhandbuch und im Produktspezifikationsblatt.
- Überschreiten Sie nicht den in Spezifikationen angegebenen maximalen HF-Eingangspegel. Informationen zum geeigneten HF-Pegel erhalten Sie im Benutzerhandbuch und im Produktspezifikationsblatt.
- Ein übermäßiger HF-Eingang könnte das Gerät oder die Anschlüsse beschädigen, was zu Sicherheitsrisiken führt.
- Im Betrieb können die HF-Spannungen an den Antennenelementen gefährlich sein. Kommen Sie nicht mit der Antenne oder Antennenelementen in Kontakt, wenn der HF-Eingang an eine live-HF-Quelle angeschlossen ist.
- Um Verletzungen an Personen, am Leistungsverstärker oder der Antenne zu vermeiden, deaktivieren Sie den HF-Ausgang des Leistungsverstärkers, bevor sie die Eingangsverbindung an die Antenne anschließen oder trennen.
- Kontrollieren Sie die Antennen und die Feldsonde regelmäßig, um die nächstfällige Kalibrierung, den ordnungsgemäßen Betrieb und den Gesamtzustand der Ausrüstung zu überprüfen.

RACK MONTIERBARE TWT-MODELLE

Einige TWT-Modelle kommen ohne die abnehmbare Überdachung, die zur Verwendung als Tischgerät dient. Diese rack-montierbaren Modelle verfügen entweder über installierte Tragegriffe oder Rutschflächen. Befolgen Sie alle in diesem Dokument angegebenen Hebehinweise sowie die Installationsanweisungen in der TWT-Bedienungsanleitung.

HEBEANWEISUNGEN FÜR AR-GERÄTE

Die meisten Geräte müssen während des Versands, der Montage und des Gebrauchs transportiert werden. Jeder Nutzer sollte sich über das Risiko von schweren Verletzungen durch unsachgemäße Produkthandhabung bewusst sein. Leitlinien zur Beseitigung von vermeidbaren Verletzungsrisikos, die beim Heben entstehen können, werden in den NIOSH-Arbeitspraktiken (Veröffentlichung # 94-110) zur Verfügung gestellt:



<https://www.cdc.gov/niosh/docs/94-110/pdfs/94-110.pdf>.

Beachten folgende, allgemeine Richtlinien zum Heben eines Gewichts von 50 Pfund oder mehr:

- Verwenden Sie zum Heben der Einheit eine Hebeöse (für Platzierung auf dem Boden) oder Seitengriffe (für Platzierung auf einer Arbeitsplatte).
- Verwenden Sie Geräte mit ausreichender Kapazität zum Heben und Stützen.
- Falls Sie einen Gabelstapler verwenden, achten Sie darauf, dass die Gabeln lange genug sind und über die Seiten der Einheit hinausreichen.
- Für weitere Informationen folgen Sie dem oben angegebenen Link.

INSTRUCTIONS POUR UN FONCTIONNEMENT EN TOUTE SÉCURITÉ









Respectez les consignes de sécurité suivantes pour veiller à votre propre sécurité et vous aider à protéger votre équipement et votre milieu de travail de dommages potentiels.

USAGE PRÉVU

Cet équipement est prévu pour un usage général en laboratoire afin de générer, contrôler et mesurer les niveaux d'énergie de radiofréquence (RF) électromagnétique. Assurez-vous que l'appareil est utilisé dans un endroit qui contrôlera l'énergie rayonnante et ne causera pas de blessure, ni ne violera les niveaux réglementaires d'interférence électromagnétique.

SYMBOLES DE SÉCURITÉ

Ces symboles peuvent apparaître dans votre manuel d'utilisation ou sur l'équipement.

	Ce symbole est apposé sur l'équipement lorsque l'utilisateur doit se référer au manuel pour des informations importantes concernant la sécurité. Le symbole de mise en garde indique un danger potentiel. Vous devez accorder une attention à la déclaration pour éviter tout dommage, destruction ou blessure.
	Présence de tensions dangereuses, soyez très prudent.
	Indique une borne de connexion d'un conducteur externe pour une protection contre l'électrocution en cas de défaillance ou la borne d'une électrode de mise à la terre de protection.
	Indique un rayonnement laser invisible – ne regardez pas directement avec des instruments optiques.
	Indique la borne de connexion de la mise à la terre du cadre ou du châssis.
	Indique un courant alternatif.
	Indique que ce produit ne doit pas être jeté avec vos autres déchets ménagers.
	Indique que la surface marquée et les surfaces adjacentes peuvent atteindre des températures qui risquent d'être chaudes au toucher.

PRÉCAUTIONS D'INSTALLATION DE L'ÉQUIPEMENT



Lisez le manuel d'utilisateur et familiarisez-vous avec tous les marquages et consignes de sécurité. La protection fournie par l'équipement peut être affaiblie s'il est utilisé d'une manière non indiquée par AR RF/instrumentation à hyperfréquence (AR).

- Respectez toutes les instructions de levage indiquées dans ce document.
- Placez l'équipement sur une surface dure et plane.

- N'utilisez pas l'équipement dans un environnement humide, par exemple près d'un lavabo, ou dans un sous-sol humide.
- Positionnez votre équipement de sorte que l'interrupteur d'alimentation soit facilement accessible.
- Laissez un espace minimal de 10,2 cm (4 in) de tous les côtés ventilés de l'équipement pour permettre le flux d'air nécessaire à une bonne ventilation. Ne limitez pas le flux d'air allant dans l'équipement en bloquant tout évent ou entrée d'air. La restriction du flux d'air peut endommager l'équipement, causer des coupures intermittentes ou des dangers pour la sécurité.
- Tenez l'équipement à l'écart de températures extrêmement chaudes ou froides pour veiller à ce qu'il soit utilisé dans la plage de fonctionnement indiquée.
- Lorsque vous installez des accessoires tels que des antennes, des coupleurs directionnels et des sondes de champ, prenez soin d'éviter toute exposition à des niveaux RF dangereux.
- Assurez-vous que rien n'est posé sur les câbles de votre équipement et que les câbles ne se trouvent pas à des endroits où l'on peut marcher dessus ou trébucher.
- Déplacez l'équipement avec soin ; veillez à ce que tous les câbles et/ou roulettes soient solidement raccordés au système. Évitez les arrêts brusques et les surfaces irrégulières.

AVANT LA MISE SOUS TENSION

Votre équipement AR peut disposer de plus d'un câble d'alimentation électrique. Utilisez uniquement un ou des câbles d'alimentation approuvés. Si un câble d'alimentation ne vous a pas été fourni avec l'équipement ou pour toute option alimentée en courant alternatif prévue pour l'équipement, achetez un câble d'alimentation qui est approuvé pour être utilisé dans votre pays. Le câble d'alimentation doit être prévu pour l'équipement et pour le courant et la tension indiqués sur l'étiquette de classement électrique de l'équipement.



Installer ou utiliser de façon incorrecte une tension de ligne incompatible peut augmenter le risque d'incendie ou d'autres dangers. Pour aider à éviter toute électrocution, branchez l'équipement et les câbles d'alimentation périphériques dans des prises électriques correctement mises à la terre. Ces câbles sont équipés de prises à trois broches pour veiller à une bonne mise à la terre. N'utilisez pas d'adaptateur de prise, ni ne retirez la broche de mise à la terre d'un câble.

Ne modifiez pas les câbles ou les prises d'alimentation. Consultez un électricien agréé ou un technicien d'entretien AR qualifié pour les modifications d'équipement. Respectez toujours les règles locales/nationales de câblage.



N'utilisez pas l'équipement s'il est physiquement endommagé ou s'il manque des pièces ou des panneaux.

MISE À LA TERRE DE SÉCURITÉ



Cet équipement est fourni avec une borne de mise à la terre de protection. La source d'alimentation secteur à l'équipement doit fournir une mise à la terre de sécurité ininterrompue de taille suffisante pour attacher les bornes de câblage, le cordon d'alimentation ou l'ensemble de câbles d'alimentation fourni. **N'UTILISEZ PAS cet équipement si cette protection est affaiblie.**

INSTRUCTIONS POUR UN FONCTIONNEMENT EN TOUTE SÉCURITÉ

TENSIONS RF DANGEREUSES

Les tensions RF sur la broche centrale d'un connecteur de sortie RF peuvent être dangereuses. Le connecteur de sortie RF doit être connecté à une charge avant que l'équipement ne reçoive l'alimentation en courant alternatif. N'entrez pas en contact avec la broche centrale du connecteur de sortie RF ou des accessoires raccordés à celle-ci. L'équipement doit être dans un état de non fonctionnement avant de déconnecter ou de connecter la charge au connecteur de sortie RF.



LIMITES ACOUSTIQUES

Si le bruit de l'équipement dépasse 80dB, une protection auditive est nécessaire.

AVERTISSEMENT CONCERNANT L'ENTRETIEN

Le réglage, l'entretien ou la réparation de l'équipement doivent être effectués uniquement par un personnel qualifié. Une énergie dangereuse peut être présente lorsque les couvercles de protection sont retirés de l'équipement, même si celui-ci est déconnecté de la source d'alimentation. Un contact peut causer des blessures. Les fusibles de remplacement doivent être d'un type et courant nominal spécifiques.

CONDITIONS ENVIRONNEMENTALES

Sauf mention contraire sur la fiche signalétique du produit, cet équipement est conçu pour être sécuritaire dans les conditions environnementales suivantes :

- Utilisation à l'intérieur
- Altitude jusqu'à 2000 m
- Température de 5°C à 40°C
- Humidité relative maximale de 80 % pour les températures jusqu'à 31°C. Décroissance linéaire à 50 % à 40°C.
- Les fluctuations de tension d'alimentation principale ne doivent pas dépasser ± 10 % de la tension nominale ou des valeurs d'autorégulation minimales et maximales.
- Degré de pollution 2 : Normalement non conducteur avec une condensation occasionnelle. Bien que l'équipement ne cause pas de condition dangereuse dans cette gamme environnementale, sa performance peut varier.

ÉQUIPEMENT CONTENANT DES LASERS



Les sondes de champ AR (série FL/PL) et les analyseurs de champ (série FA) sont des produits laser de classe 1 contenant des lasers intégrés de classe 4. Lors d'une utilisation normale, le rayonnement laser est entièrement contenu dans les câbles à fibres optiques et ne pose aucun risque d'exposition. Des verrouillages de sécurité veillent à ce que le laser ne soit pas activé à moins que les câbles ne soient correctement raccordés. Soyez toujours prudent lorsque vous utilisez ou entretenez des produits laser. Ne regardez pas directement avec des instruments optiques.

ANTENNES RF

- Cet équipement (antenne ou ensemble antenne) peut être lourd nécessitant deux personnes pour le soulever. Soyez prudent lorsque vous installez ou retirez l'unité. Respectez toutes les instructions concernant l'installation et le levage de l'équipement indiquées dans ce document.

- Assurez-vous que les connecteurs sont appropriés pour l'utilisation prévue. Les connecteurs sont indiqués dans le manuel d'utilisation et la fiche signalétique du produit.
- Ne dépassez pas le niveau d'entrée RF maximal indiqué dans les spécifications. Référez-vous au manuel d'utilisation et à la fiche signalétique du produit pour déterminer les niveaux RF applicables.
- Une entrée RF excessive pourrait endommager l'équipement ou les connecteurs causant des dangers pour la sécurité.
- Lorsque l'équipement fonctionne, les tensions RF sur les éléments de l'antenne peuvent être dangereuses. N'entrez pas en contact avec l'antenne ou les éléments lorsque le connecteur d'entrée RF est connecté à une source RF active.
- Pour éviter que le personnel ne se blesse et que l'amplificateur de puissance ou l'antenne ne soit endommagé, désactivez la sortie RF de l'amplificateur de puissance avant de brancher ou débrancher la connexion d'entrée à l'antenne.
- Effectuez des inspections périodiques de l'antenne et des systèmes de sondes de champ pour vérifier la date d'échéance de la calibration, le bon fonctionnement et l'état global de l'équipement.

MODÈLES TWT MONTÉS SUR BÂTI

Certains modèles TWT sont fournis sans le boîtier amovible proposé pour l'utilisation sur un plan de travail. Ces modèles montés sur bâti peuvent être fournis avec des poignées de transport ou des coulisses et poignées frontales. Respectez toutes les instructions de levage indiquées dans ce document et les instructions d'installation fournies dans le manuel d'utilisation TWT.

INSTRUCTIONS DE LEVAGE POUR L'ÉQUIPEMENT AR

Comme la plupart des produits doivent être manipulés pendant la distribution, l'assemblage et l'utilisation, le risque de blessures graves en raison d'une manipulation dangereuse du produit doit être une considération fondamentale pour chaque utilisateur. Une directive faisant autorité pour éliminer le risque injustifié de blessures causées par le levage est fournie par les méthodes de travail de NIOSH (publication n° 94-110) disponibles sur :



<https://www.cdc.gov/niosh/docs/94-110/pdfs/94-110.pdf>.

De façon générale, respectez les directives suivantes pour lever un poids de 50 lb (22 kg) ou plus :

- Utilisez uniquement l'anneau de levage (si posé au sol) ou les poignées latérales (si sur la table) pour soulever l'unité.
- Utilisez un équipement de capacité adéquate pour soulever et supporter l'unité.
- Si vous utilisez un chariot élévateur pour déplacer l'unité, assurez-vous que les fourches sont assez longues pour s'étendre au-delà du côté de l'unité.
- Pour plus d'informations, suivez le lien indiqué ci-dessus.

INSTRUCTIES VOOR VEILIG GEBRUIK

Neem de volgende veiligheidsrichtlijnen in acht om uw persoonlijke veiligheid te helpen waarborgen en uw apparaat en werkomgeving tegen mogelijke schade te beschermen.

BEOOGD GEBRUIK

Dit apparaat is bedoeld voor algemeen laboratoriumgebruik bij het genereren, regelen en meten van niveaus van elektromagnetische radiofrequentie(RF)-energie. Zorg ervoor dat het apparaat wordt gebruikt op een locatie die de uitgestraalde energie controleert, geen letsel veroorzaakt of de reglementaire niveaus van elektromagnetische interferentie schendt.

VEILIGHEIDSSYMBOLEN

Deze symbolen kunnen in uw gebruikershandleiding of op uw apparaat verschijnen.

	Dit symbool staat op het apparaat als de gebruiker de handleiding moet raadplegen voor belangrijke veiligheidsinformatie. Het waarschuwingssymbool geeft een mogelijk gevaar aan. Er moet aandacht worden besteed aan de verklaring om schade, vernietiging of letsel te voorkomen.
	Er zijn gevaarlijke elektrische spanningen aanwezig. Wees uiterst voorzichtig.
	Wijst op een terminal aan die bedoeld is voor aansluiting op een externe geleider voor bescherming tegen elektrische schokken in het geval van een storing, of de terminal van een veiligheidselektrode (aarding).
	Wijst op een onzichtbare laserstraling - bekijk niet rechtstreeks met optische instrumenten.
	Wijst op het frame of het chassis van de aardingsterminal.
	Wijst op wisselstroom.
	Geeft aan dat dit product niet bij het huishoudelijk afval mag worden weggegooid.
	Geeft aan dat het gemarkeerde oppervlak en de aangrenzende oppervlakken temperaturen kunnen bereiken, die warm aanvoelen.

VOORZORGSMAATREGELEN BIJ DE INSTALLATIE VAN HET APPARAAT



Raadpleeg de gebruikershandleiding en leer alle veiligheidsmarkeringen en -instructies kennen. De bescherming die door het apparaat wordt geboden, kan worden belemmerd bij gebruik op een manier die niet wordt vermeld door AR RF/Microwave Instrumentation (AR).

- Respecteer alle tilinstructies die in dit document vermeld zijn.
- Plaats het apparaat op een hard, waterpas oppervlak.
- Gebruik het apparaat niet in een natte omgeving, bijvoorbeeld in de buurt van een gootsteen of in een vochtige kelder.
- Plaats uw apparaat zodanig dat de aan/uit-schakelaar gemakkelijk bereikbaar is.

Revisie 0517

- Laat een vrije ruimte van 10,2 cm (4 inch) aan alle geventileerde zijden van het apparaat om de luchtstroom die nodig is voor goede ventilatie mogelijk te maken. Belemmer de luchtstroom in het apparaat niet door ventilatieopeningen of luchtinlaten te blokkeren. Het belemmeren van de luchtstroom kan leiden tot schade aan het apparaat, onregelmatige uitval van veiligheidscrisis's.
- Houd het apparaat uit de buurt van extreem hoge of lage temperaturen om ervoor te zorgen dat het apparaat binnen het gespecificeerde werkbereik wordt gebruikt.
- Bij de installatie van accessoires zoals antennes, directionele koppelingen en terreinsondes, moet u ervoor zorgen dat blootstelling aan gevaarlijke RF-niveaus wordt voorkomen.
- Zorg ervoor dat er niets op de kabels van uw apparaat rust en dat de kabels zich niet op een plaats bevinden, waar er op getrapt kan worden of waar er over gestruikeld kan worden.
- Verplaats de apparatuur voorzichtig; zorg ervoor dat alle zwenkwielen en/of kabels stevig op het systeem zijn aangesloten. Vermijd plotselinge stops en oneffen oppervlakken.

VOOR HET OPZETTEN VAN DE STROOM

Uw AR-apparatuur kan meer dan een netvoedingskabel bezitten. Gebruik alleen goedgekeurde netvoedingskabel(s). Koopt een netvoedingskabel die is goedgekeurd voor gebruik in uw land als u geen netvoedingskabel hebt ontvangen voor de apparatuur of voor een door wisselstroom aangedreven optie, die bedoeld is voor de apparatuur. De netvoedingskabel moet geschikt zijn voor het apparaat en voor de spanning en stroomsterkte die op het label met de elektrische classificatie van het apparaat staat vermeld.



Het verkeerd installeren of gebruiken van een incompatibele netspanning kan het risico op brand of andere gevaren verhogen. Sluit het apparaat en de perifere netvoedingskabels aan op geaarde stopcontacten om elektrische schokken te helpen voorkomen. Deze kabels zijn uitgerust met driepolige stekkers om voor een goede aarding te zorgen. Gebruik geen adapterstekkers of verwijder de aardingspen van een kabel niet.

Pas geen netvoedingskabels of stekkers aan. Raadpleeg een bevoegde elektricien of een door AR opgeleide servicemonteur voor aanpassingen van de apparatuur. Respecteer altijd uw lokale/nationale bedravingsreglementering.



Gebruik de apparatuur niet als er sprake is van fysieke schade, ontbrekende hardware of ontbrekende panelen.

AARDING



Deze apparatuur is voorzien van een beschermende aardingsterminal. De stroombron van de apparatuur moet een ononderbroken veiligheidsaarding van voldoende grootte leveren om de aansluitklemmen, de netvoedingskabel of de meegeleverde netvoedingskabelset aan te sluiten. **GEBRUIK dit apparaat NIET als deze bescherming is beschadigd.**

INSTRUCTIES VOOR VEILIG GEBRUIK

GEVAARLIJKE RF-SPANNINGEN

De RF-spanning op de middelste pin van een RF-outputconnector kan gevaarlijk zijn. De RF-uitgangconnector moet op een massa worden aangesloten voordat er wisselstroom op het apparaat wordt geplaatst. Raak de middelste pin van de RF-outputconnector of de accessoires die erop zijn aangesloten, niet aan. Plaats het apparaat in een niet-werkende staat voordat u de massa loskoppelt of verbindt met de RF-outputconnector.



AKOESTISCHE BEPERKINGEN

Als het geluid van het apparaat 80dB overschrijdt, is gehoorbescherming vereist.

ONDERHOUD WAARSCHUWING

Aanpassing, onderhoud of reparatie van de apparatuur mag alleen worden uitgevoerd door gekwalificeerd personeel. Er kan gevaarlijke energie aanwezig zijn terwijl beschermende afdekkingen van de apparatuur worden verwijderd, zelfs als deze van de stroombron is losgekoppeld. Contact kan tot persoonlijk letsel leiden. Wisselzekeringen moeten van het hetzelfde type en dezelfde stroomsterkte zijn.

OMGEVINGSVOORWAARDEN

Tenzij anders op het productspecificatieblad is vermeld, is dit apparaat ontworpen om veilig te zijn onder de volgende omgevingsomstandigheden:

- Binnengebruik
- Hoogte tot 2000 m
- Temperatuur van 5 °C to 40 °C
- Maximale relatieve vochtigheid 80% voor temperaturen tot 31 °C. Lineair afnemend tot 50% bij 40 °C.
- Schommelingen in de netspanning mogen niet groter zijn dan $\pm 10\%$ van de nominale spanning of minimum en maximum autobereikwaarden.
- Vervuilinggraad 2: Normaal niet-geleidend met incidentele condensatie. Hoewel het apparaat geen gevaarlijke toestand veroorzaakt boven dit omgevingsbereik, kunnen de prestaties variëren.

APPARAAT DAT LASERS BEVAT



AR-terreinsondes (FL/PL-serie) en terreinanalysatoren (FA-serie) zijn laserproducten van klasse 1 met ingesloten klasse 4-lasers. Bij normaal gebruik is de laserstraling volledig vervat in de glasvezelkabels en vormt ze geen bedreiging voor blootstelling. Veiligheidsvergrendelingen zorgen ervoor dat de laser niet wordt geactiveerd, tenzij de kabels correct zijn aangesloten. Wees altijd voorzichtig bij het gebruik of het onderhoud van laserproducten. Bekijk niet rechtstreeks met optische instrumenten.

RF-ANTENNES

- Dit apparaat (antenne of antenne-set) kan zwaar zijn, waardoor er twee personen nodig zijn om het op te tillen. Wees voorzichtig bij het installeren of verwijderen van het apparaat. Respecteer alle instructies voor het instellen en optillen van de apparatuur, die in dit document worden vermeld.
- Zorg ervoor dat de connectoren geschikt zijn voor de beoogde werking. De connectoren worden gespecificeerd in de gebruikershandleiding en in het productspecificatieblad.
- Overschrijd het maximale RF-ingangsniveau niet, dat in de specificaties is vermeld. Raadpleeg de gebruikershandleiding en het productspecificatieblad om de toepasselijke RF-niveaus te bepalen.
- Een overmatige RF-input kan het apparaat of de connectoren beschadigen en veiligheidsrisico's veroorzaken.
- De RF-spanningen op de antenne-elementen kunnen gevaarlijk zijn tijdens het gebruik. Raak de antenne of elementen niet aan wanneer de RF-ingangconnector is aangesloten op een actieve RF-bron.
- Om persoonlijk letsel en onopzettelijke schade aan de vermogensversterker of antenne te voorkomen, schakelt u de RF-output van de vermogensversterker uit voordat u de inputaansluiting op de antenne aansluit of loskoppelt.
- Voer periodieke inspecties uit van de antenne- en terreinsondesystemen om de vervaldatum van de kalibratie, de juiste werking en de algehele conditie van de apparatuur te controleren.

IN EEN REK GEMONTEERDE TWT-MODELLEN

Sommige TWT-modellen worden geleverd zonder de verwijderbare behuizing die wordt aangeboden voor gebruik als tafemodel. Deze modellen die in een rek kunnen worden gemonteerd, kunnen worden geleverd met handgrepen of sledes en handgrepen die aan de voorkant zijn geïnstalleerd. Volg alle tilinstructies in dit document en de installatie-instructies in de gebruikershandleiding van de TWT.

TILINSTRUCTIES VOOR AR-APPARATUUR

Omdat de meeste producten tijdens de distributie, de assemblage en het gebruik moeten worden behandeld, moet het risico op ernstig letsel als gevolg van een onveilige behandeling van het product een fundamentele overweging voor elke gebruiker zijn. Een gezaghebbende richtlijn voor het elimineren van ongerechtvaardigd risico op letsel veroorzaakt door tillen, wordt aangeboden door de NIOSH-Work Practices (publicatie # 94-110) en is beschikbaar op:



<https://www.cdc.gov/niosh/docs/94-110/pdfs/94-110.pdf>.

Neem in het algemeen de volgende richtlijnen in acht voor het optillen van een gewicht van 25 kg of meer:

- Gebruik alleen het hijsorg (vloermodel) of de zijhandgrepen (tafelmodel) om de eenheid op te tillen.
- Gebruik apparatuur met voldoende capaciteit om de eenheid op te tillen en te ondersteunen.
- Als u een vorkheftruck gebruikt om de eenheid te verplaatsen, zorg er dan voor dat de vorken lang genoeg zijn om tot voorbij de zijkant van het eenheid uit te steken.
- Volg de link hierboven voor meer informatie.

TABLE OF CONTENTS

TABLE OF CONTENTS	i
1. GENERAL INFORMATION	1
1.1 General Description.....	1
1.2 Power Supplies.....	1
1.3 Specifications	1
2. OPERATING INSTRUCTIONS	5
2.1 General	5
2.2 Amplifier Front and Rear Panels.....	6
2.3 Interface Identification	6
2.3.1 Local Controls.....	6
2.4 Local User Interface	8
2.4.1 Menu Map	8
2.4.2 Main Menu Screen	8
2.4.3 User Screen	9
2.4.4 I/O Screen.....	9
2.4.5 GPIB Address Screen.....	10
2.4.6 RS-232/Fiber-Optic Serial Baud Rate Screen	10
2.4.7 Key Beep Screen.....	11
2.4.8 Remote Screen.....	11
2.4.9 Fault Screen.....	12
2.5 Control States	12
2.5.1 Power Off, RF Off.....	13
2.5.2 Power On, RF Off	13
2.5.3 Power On, RF On	13
2.6 Control Lines.....	14
2.6.1 Switch Breakout Board (A12A3).....	14
2.7 Fault Definition	16
2.8 No-Fault Control Actions (Utilized on Amplifiers 1000 Watts and Above)	17
2.9 Remote Control Interfaces.....	18
2.9.1 GPIB (IEEE-488) Communications	18
2.9.2 RS-232 Communications	18
2.9.3 Fiber-Optic Serial Communications.....	19
2.9.4 USB Communications.....	19
2.9.5 Ethernet Communications	20
2.10 Remote Commands	21
2.10.1 Power On / Off.....	21
2.10.2 RF On / Off	21
2.10.3 RF Gain Adjust.....	21
2.10.4 RF Gain Query	22
2.10.5 Identity Query	22
2.10.6 IO Board Firmware Revision Query	22
2.10.7 Amplifier State Query	23
2.10.8 Operating Hours (RF ON) Query	24
2.10.9 Operating Hours (Power ON) Query.....	25
2.10.10 Faults Query	25
2.10.11 Reset Faults	25

2.10.12 SBB (Piggyback) Firmware Query	25
2.10.13 System Serial Number Query.....	26
3. THEORY OF OPERATION.....	27
3.1 Introduction	27
3.2 RF Amplifier Operation	27
3.2.1 A1A1 Pre-Amp	27
3.2.2 A4 20-Watt Module.....	27
3.3 Power Supply	28
3.3.1 A7 Regulator Fault Board (Schematic 10044490).....	28
3.4 Control System.....	28
3.4.1 A12A1 Control/Fault Board (Schematic 10029678).....	28
4. MAINTENANCE	29
4.1 General Maintenance Information.....	29
4.2 Disassembly Procedure	29
4.3 Troubleshooting	30
4.3.1 Power On Indication Doesn't Display on Front Panel Liquid Crystal Display (LCD) when POWER Switch is Depressed (Schematic Diagram 10050716).....	31
4.3.2 The Unit Cannot Be Operated Remotely.....	31
4.3.3 Thermal Fault (Schematic Diagram 10050716).....	31
4.3.4 Interlock Fault (Schematic Diagram 10050716).....	32
4.3.5 PS2 Fault (Schematic Diagram 10050716).....	32
4.3.6 Amplifier Faults (Schematic Diagram 10050716).....	32
4.3.7 Liquid Coolant.....	33
4.3.8 Low or No Power Output (DC Tests) (Schematic Diagram # 10050716).....	33
4.4 Cooling System	36

FIGURES

2-1 Model 20S6G18A-L Front Panel	6
2-2 Model 20S6G18A-L Rear Panel	6
4-1 Typical Gain Response @ 0dBm Input.....	34
4-2 Typical Gain Response @ -20 dBm Input	35
4-3 Typical Response: Input A4 – Front Panel RF Output.....	35
4-4 Typical A1A1 Pre-Amp Response	36

1. GENERAL INFORMATION

1.1 GENERAL DESCRIPTION

The Model 20S6G18A-L is a self-contained, broadband microwave amplifier designed for laboratory applications where instantaneous bandwidth, high gain, and moderate power output are required. A **GAIN** control, which is conveniently located on the unit's front panel, can be used to decrease the amplifier's gain by 10 decibels (dB) or more. Solid state technology is used exclusively to offer significant advantages in reliability and cost. A Model 20S6G18A-L, used with a frequency-swept signal source, will provide 20 watts of swept power output from 6.0–18 gigahertz (GHz). Typical applications include antenna and component testing, wattmeter calibration, and electromagnetic interference (EMI) susceptibility testing, as well as usage as a driver for frequency multipliers and high-power amplifiers. The Model 20S6G18A-L can be operated locally by using the unit's front panel controls, or remotely by using the unit's IEEE-488, RS-232 interface, USB, or Ethernet interface.

1.2 POWER SUPPLIES

The Model 20S6G18A-L contains a switching power supply. The input voltage range to the power supply is 90–264 VAC, 47-440Hz, selected automatically.

PS1 is a multiple output supply. The main +24, +12, -12 and +5 volts DC supplies voltage to the RF low level and final stages. The +24 and +12 volts DC are for operating the cooling fans. Primary AC circuit protection is provided by the circuit breaker in the Power Entry Module. PS1 also contains a +5V housekeeping supply for both the A12A1 Control/Fault Board and the A14 Interface board used for the remote interfaces.

PS2 is a single output supply and provides 26.3V to the 20 watt amplifier A4.

1.3 SPECIFICATIONS

Refer to the AR Data Sheet at the end of this section for detailed specifications. All voltage measurements referenced in this manual are Direct Current (DC) unless stated otherwise.

Amplifiers

Model 20S6G18A-L

Features:

- 20 W CW, 6 - 18 GHz
- Class A design
- 100% mismatch tolerant
- Built-in fault monitoring and protection
- Remote control: Ethernet, USB, GPIB, fiber-optic serial, RS-232
- Modular design for easy maintenance and service
- Low acoustical noise

Applications:

- EMC (military, aviation, automotive, commercial)
- Radiated and conducted EMC testing
- General purpose, antenna, and component testing
- CDMA, W-CDMA, TDMA, GSM, UWB, WiMAX etc.

To view our full amplifier portfolio visit:

www.arworld.us/amplifiers

AR RF/Microwave Instrumentation

160 Schoolhouse Rd

Souderton, PA 18964

215.723.8181

info@arworld.us

www.arworld.us

ISO 9001:2015 Certified

ISO 17025 :2017 Accredited



The Model 20S6G18A-L is a solid-state, Class A design, self-contained, liquid-cooled, broadband power amplifier designed for applications where instantaneous bandwidth, high gain and linearity are required. It will provide a minimum of 20 W across its operating bandwidth. Protection from input overdrive beyond 0 dBm is provided as well as protection from various failure conditions including over-temperature and power supply faults.

A front panel display indicates the operational status and fault conditions. All amplifier control functions, and status indications are available remotely using GPIB/IEEE-488, RS-232, fiber-optic serial, USB, or Ethernet. Interface connectors are located on the back panel. Local and remote operation is managed by a switch on the front panel.

This is a multiple purpose amplifier. The low level of spurious signals and linearity make it ideal for use as a driver in testing wireless and communication components and subsystems. By covering such a wide bandwidth, it is suitable for a variety of communication technologies such as CDMA, W-CDMA, TDMA, GSM, UWB, WiMAX etc.

The export classification for this equipment is 3A001. These commodities, technology or software are controlled for export in accordance with the U.S. Export Administration Regulations. Diversion contrary to U.S. law is prohibited.

Model 20S6G18A-L

- 20 W
- 6 - 18 GHz

Electrical Specifications					
Parameter	Symbol	Minimum	Typical	Maximum	Unit
Rated Power Output (6 - 18 GHz)	PSAT	20	30	>60	W
Input for Rated Output	Pin			1.0	mW
				0	dBm
Power Output @ 1 dB Compression	P1dB	15	22	>45	W
Power Output @ 3 dB Compression	P3dB	18	25	>55	W
Operating Frequency	BW	6.0		18.0	GHz
Gain (Small Signal)		45	47	49	dB
Gain Reduction Adjustment (when below compression)		10			dB
Flatness	ΔG		± 2.0	± 2.5	dB
Input Impedance	Z in		50		Ohm
				2.5:1	VSWR
Output Impedance	Z out		50		Ohm
3 rd Order Intercept	IP3		49		dBm
Harmonic Distortion @ 20 W	H2, H3			20	dBc
Power Consumption	PD			600	W

Absolute Maximum Rating				
Exceeding any of the limits listed here may result in permanent damage to the device.				
Parameter	Minimum	Typical	Maximum	Unit
RF Drive		0	+13	dBm
RF Load		1:1	∞	VSWR
RF Load Reflected Will operate without damage or oscillation when connected to any load impedance without the aid of foldback circuitry.			100	%
AC Power (single phase)	100		240	VAC
	47		63	Hz
Ambient Temperature	+5	+25	+40	°C
Storage Temperature	-20		+50	°C
Altitude			2000	m
Shock/Vibration	Normal Truck Transport			



Model 20S6G18A-L

- 20 W
- 6 - 18 GHz

Mechanical Specifications		
Parameters		Unit
Dimensions (With Cabinet) (W x H x D)	50.2 x 20.6 x 63.2	cm
	19.8 x 8.1 x 24.9	in
Dimensions (No Cabinet) – 4U for 19" Rack	48.3 x 18.0 x 62.5	cm
	19.0 x 7.1 x 24.6	in
Weight (With Cabinet)	29.5	kg
	65	lb
Weight (No Cabinet)	20.4	kg
	45	lb
Cooling	Forced air (internal self-contained liquid)	
Acoustical Noise (Measured @ 1 meter from the front)	58 (typical)	dBA

Regulatory Compliance	
Type	Standard
EMC	EN 61326-1
Safety	UL 61010-1
	CAN/CSA C22.2 #61010-1
	CENELEC EN 61010-1
RoHS	Directive 2011/65/EU
Export	3A001

Connector interfaces	
Function	Type
RF input	N female (50 Ω)
RF output	N female (50 Ω)
IEEE-488	24-pin female
RS-232	9-pin subminiature D female
RS-232 (fiber optic)	ST
USB 2.0	Type B
Ethernet	RJ-45
Interlock	15-pin subminiature D female

Ordering Options

20S6G18A-L	-	-	N	-	-	N	-	-	-										
Model			RF IN Conn Location, Type			RF OUT Conn Location, Type			Enclosure No Enclosure										
<table border="1"> <thead> <tr> <th colspan="2">Connector</th> </tr> </thead> <tbody> <tr> <td>Front</td> <td>F</td> </tr> <tr> <td>Rear</td> <td>R</td> </tr> </tbody> </table>		Connector		Front	F	Rear	R	<table border="1"> <thead> <tr> <th colspan="2">Enclosure</th> </tr> </thead> <tbody> <tr> <td>Enclosure</td> <td>E</td> </tr> <tr> <td>No Enclosure</td> <td>NE</td> </tr> </tbody> </table>		Enclosure		Enclosure	E	No Enclosure	NE				
Connector																			
Front	F																		
Rear	R																		
Enclosure																			
Enclosure	E																		
No Enclosure	NE																		

AR RF/Microwave Instrumentation • 160 Schoolhouse Rd, Souderton, PA 18964 • 215-723-8181 • info@arworld.us • www.arworld.us • ISO 9001:2015 Certified • ISO 17025:2017 Accredited



Model 20S6G18A-L

- 20 W
- 6 - 18 GHz

Envelope Drawing

20S6G18-L with Cabinet

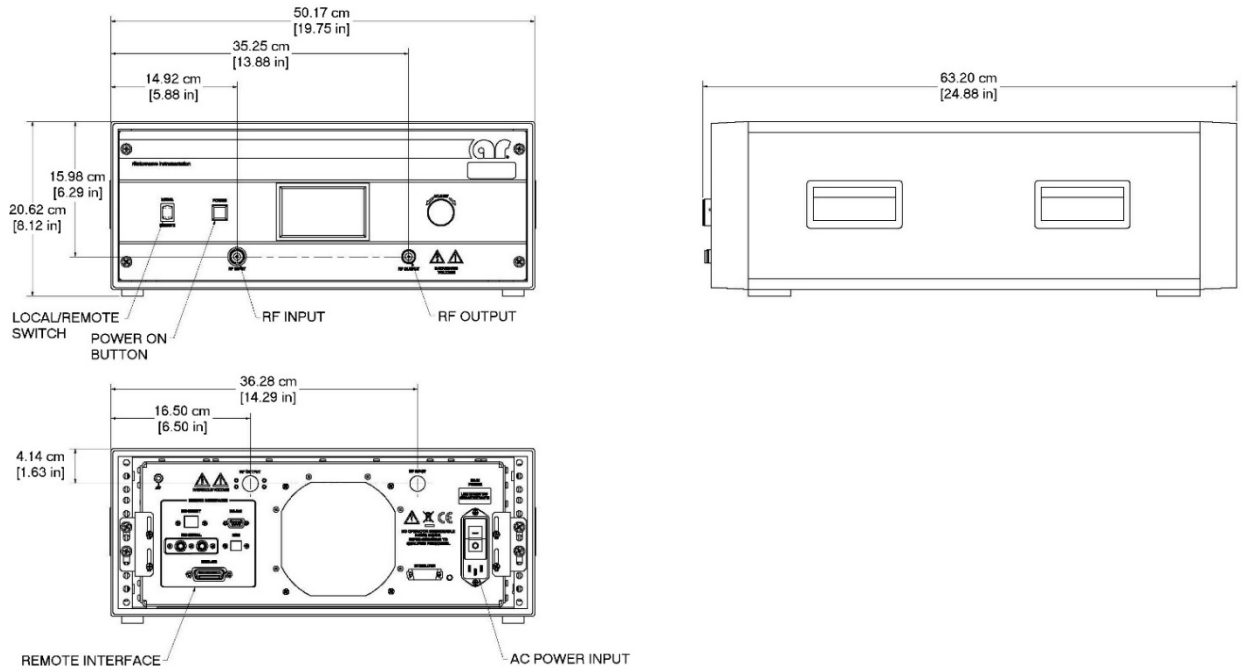

20S6G18-L without Cabinet

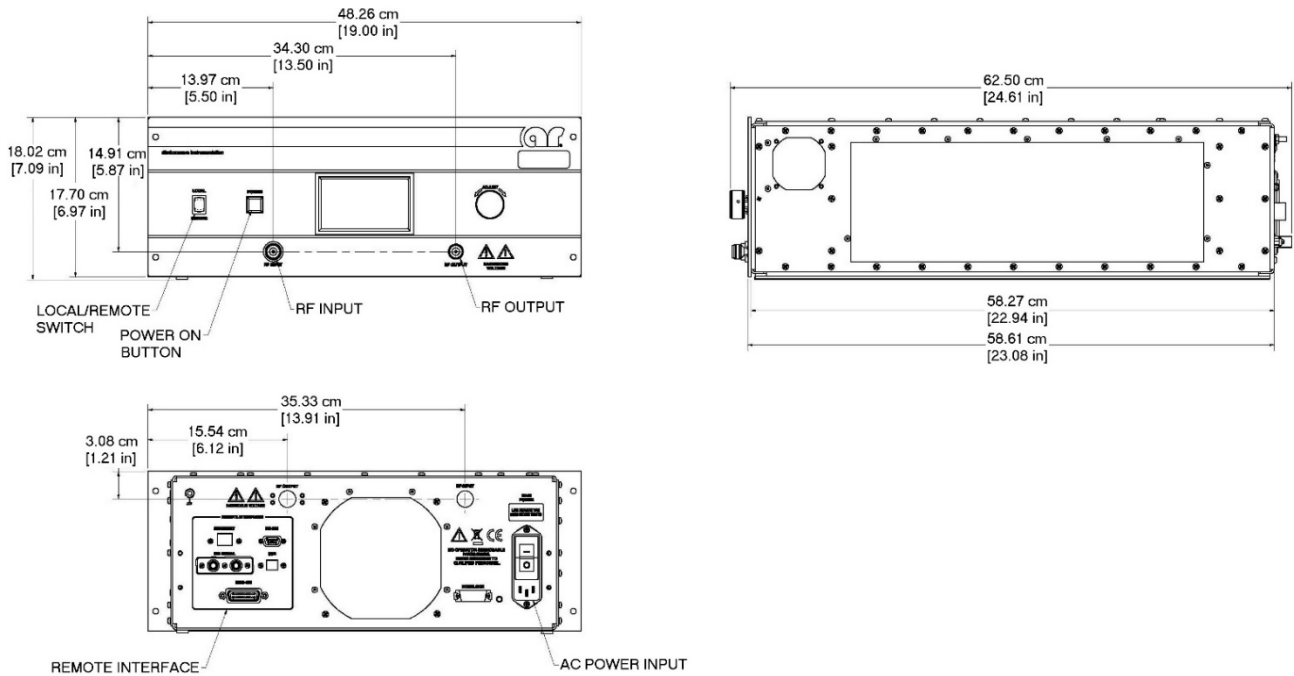

Model 20S6G18A-L

- 20 W
- 6 - 18 GHz

TYPICAL PSAT POWER @ 0dBm INPUT

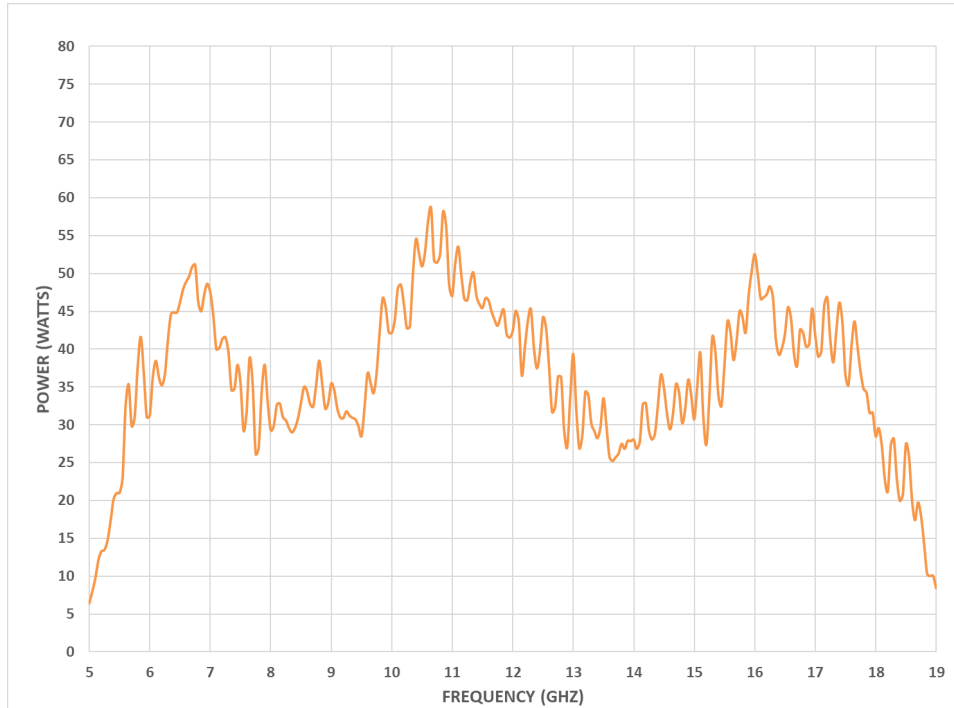

TYPICAL POWER @ P3dB COMPRESSION

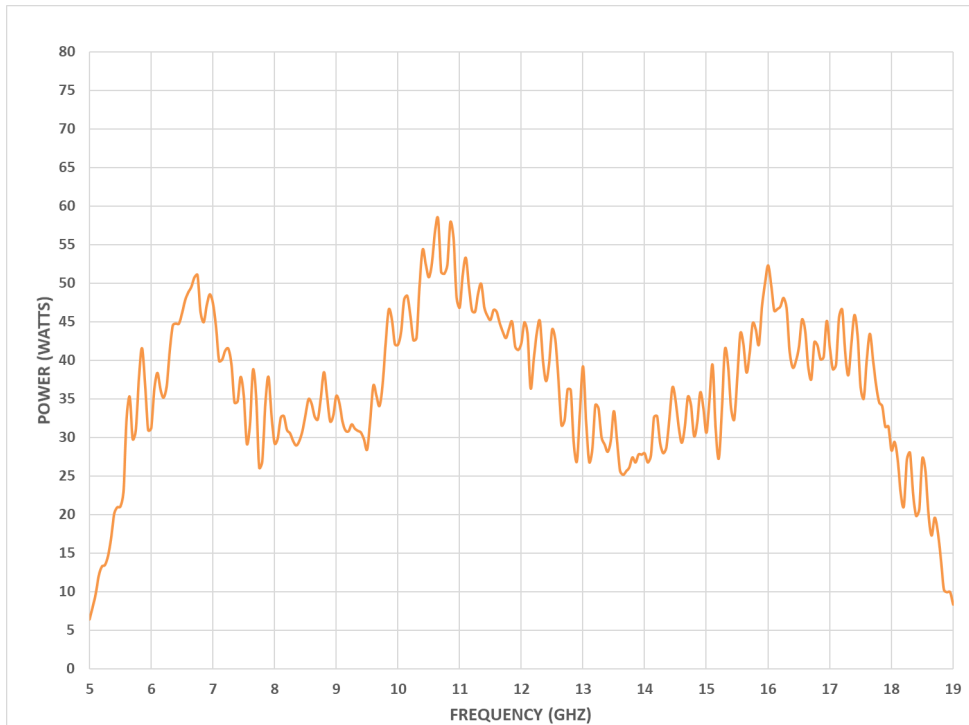

Model 20S6G18A-L

- 20 W
- 6 - 18 GHz

TYPICAL POWER @ P1dB COMPRESSION

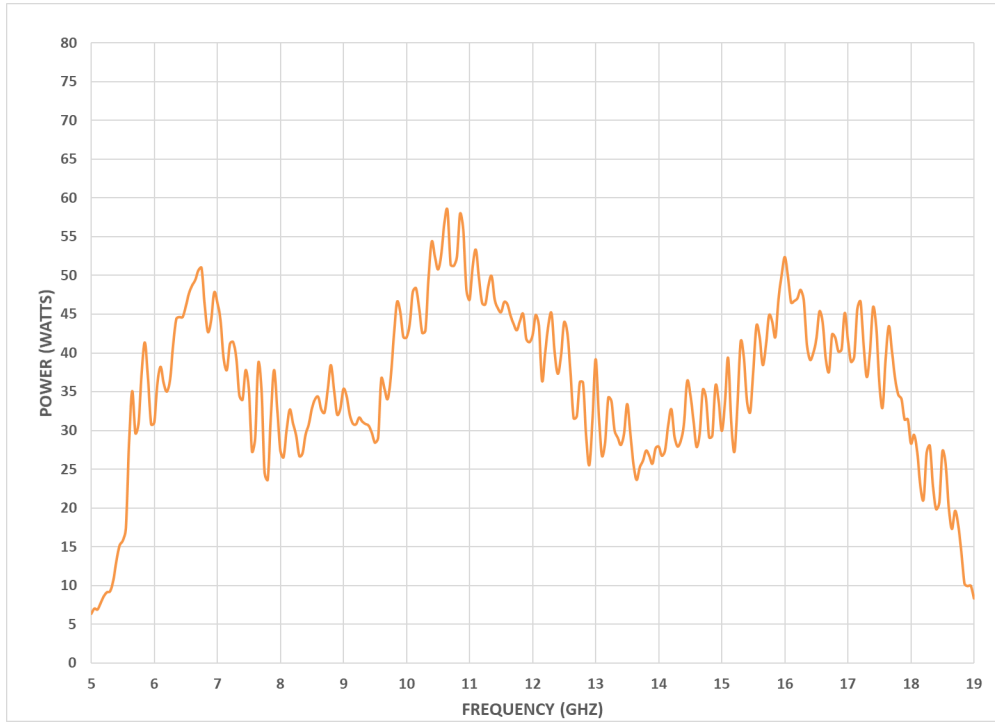

TYPICAL SMALL SIGNAL GAIN @ -20dBm INPUT

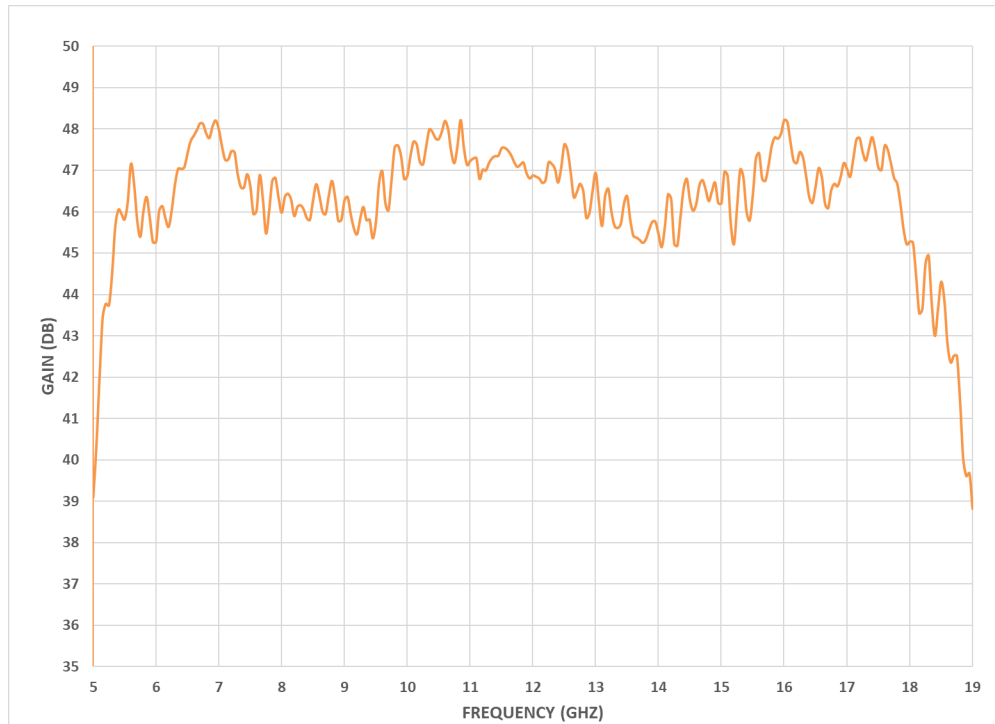

Model 20S6G18A-L

- 20 W
- 6 - 18 GHz

TYPICAL 2nd HARMONIC @ 20 WATTS OUTPUT

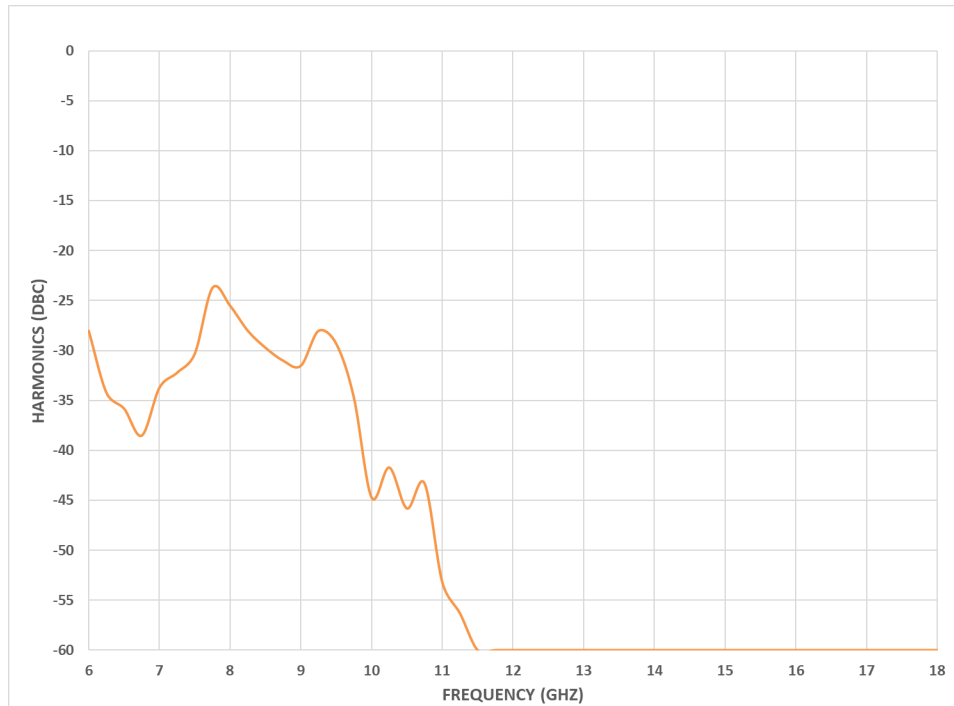

TYPICAL 3rd HARMONIC @ 20 WATTS OUTPUT

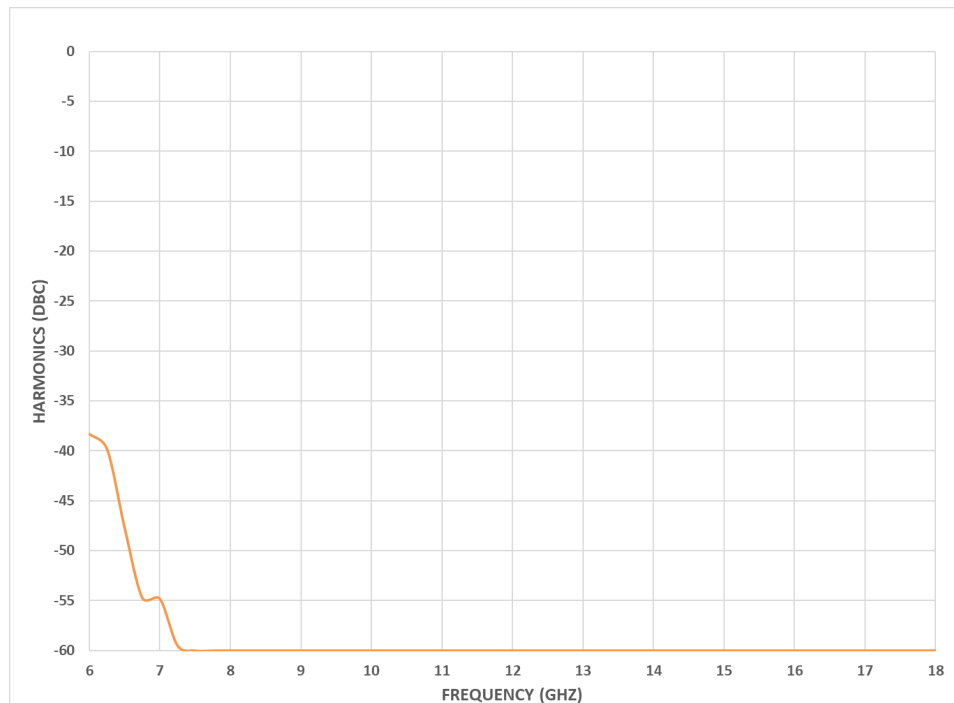

AR RF/Microwave Instrumentation • 160 Schoolhouse Rd, Souderton, PA 18964

To order AR Products, call: 215.723.8181. For an applications engineer, call: 800.933.8181. Direct to Service call: 215.723.0275 or email: service@arworld.us

For Faxing Orders: 866.859.0582 (Orders Only Please) info@arworld.us

Approved for public release by AR RF/Microwave Instrumentation ISO 9001:2015 Certified • ISO 17025:2017 accredited

Revision 051322



2. OPERATING INSTRUCTIONS

2.1 GENERAL

Operation of the Model 20S6G18A-L broadband amplifier is simple. The input signal, whether swept or fixed in frequency, is fed into the jack marked INPUT and the amplifier output signal is taken from the jack labeled OUTPUT. The unit is turned ON by activating the power switch. In the event of a unit malfunction, protection is provided by a circuit breaker located in the AC input receptacle. A polarized, three (3) wire AC power cord is also included with the unit to provide cabinet and chassis grounding to the power mains.



CAUTION:

The Model 20S6G18A-L amplifier is not critical in regard to source and load VSWR and will remain unconditionally stable with any magnitude and phase of source and load VSWR. It is designed to withstand, without damage, RF input power up to twenty (20) times its rated input of 1mW. However, signal levels higher than 20mW or transients with high peak voltages can damage the amplifier. Also, accidental connection of the 20S6G18A-L output to the input causes oscillations which will permanently damage the input circuitry.



CAUTION:

Although designed for overdrive and load tolerance described above, subjecting the amplifier to these conditions simultaneously can cause failure of the output transistor. Repeated failures of this nature will not be covered under warranty.

The 20S6G18A-L Amplifier is protected from input overdrive by an automatic level control circuit which will limit the maximum RF level to the first gain stage (A1A1) of the RF Amplifier to approximately 0 dBm. The 20S6G18A-L RF power transistors are protected from over temperature by sensing the chassis temperature near the RF output transistors. In the event of a cooling fan failure or an airflow blockage, the DC voltage will be removed from the RF stages, when the chassis temperature reaches approximately 70°C.

Normal operation can be resumed after the chassis temperature drops below 70° C.

2.2 AMPLIFIER FRONT AND REAR PANELS

Figure 2-1 shows the front panel of the Model 20S6G18A-L Broadband Microwave Amplifier. Figure 2-2 shows the rear panel of the Model 20S6G18A-L Broadband Microwave Amplifier.

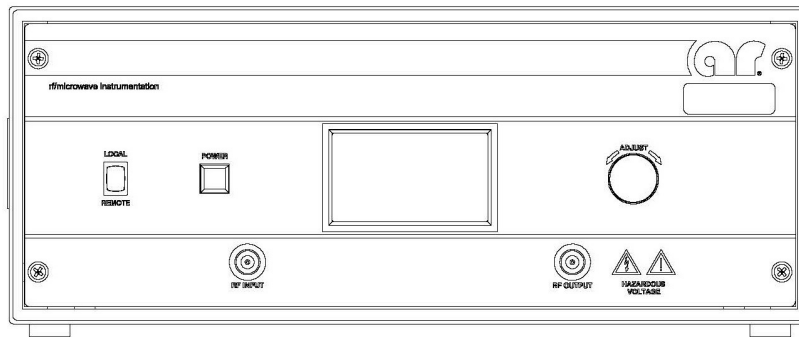

Figure 2-1. Model 20S6G18A-L Front Panel

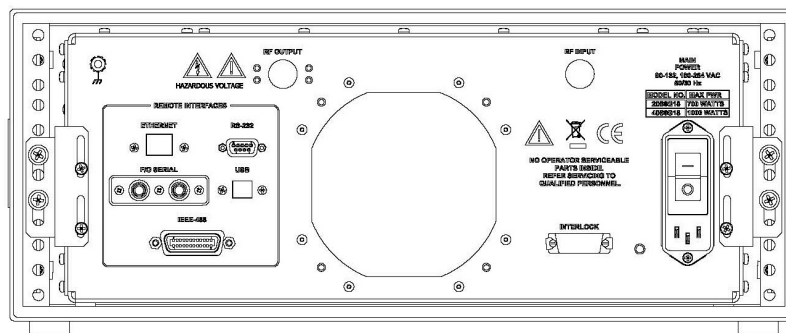

Figure 2-2. Model 20S6G18A-L Rear Panel

2.3 INTERFACE IDENTIFICATION

This section describes all external interfaces used to operate the amplifier via the control software. A Local/Remote switch on the front panel can allow control from the Local Controls or Remote Communications Ports.

2.3.1 Local Controls

The control panel located on the front of the amplifier allows for local control and status monitoring using the controls listed below.

2.3.1.1 Local/Remote Toggle Switch

The Local/Remote toggle switch provides protection from unauthorized use or unexpected remote control of the amplifier. The amplifier can only be turned on locally when the Switch is in the LOCAL position. Likewise, the unit can only be turned on or controlled remotely when the Switch is in the REMOTE position. All remote queries are processed and responded to in either switch position.

2.3.1.2 Power Button

The momentary POWER button turns the main power to the amplifier on and off. The status of the green light-emitting diode (LED) in the switch indicates whether the amplifier's power is on or off. The main power supply fans are active when power is on. The LCD touch display is active as long as the main circuit breaker for the amplifier power entry module is on.

2.3.1.3 Adjust Knob

The ADJUST knob is used to set the value of the RF Gain between 0 and 100 percent. The ADJUST knob can be rotated both clockwise and counterclockwise 360 degrees.

2.3.1.4 Touch Screen

The touch screen is a color LCD that can accept single touch events from soft blunt objects such as a human finger. The mechanism that registers touch events is resistive based and relies on pressure not capacitance. Menu options presented on the touch screen are typically gray in color with a black text label in the center. When a valid touch event is registered a thin black box appears around the valid touch location and an optional audible beep will occur.

2.3.1.5 Remote Communications Ports

The Remote option allows for control of the amplifier using GPIB, USB, Ethernet, Fiber-Optic (serial) or RS-232 Serial ports located on the rear of the amplifier.

2.3.1.6 Interlocks

The amplifier has one interlock circuit that is wired to the rear panel Safety Interlock connector. This interlock requires a normally closed external circuit to allow the unit to function.

This interlock circuit inhibits RF amplification by disabling the low level (A1) amplifier stages.

The Inhibit Interlock is wired to the rear panel interlock connector pins 1 and 8. A closed circuit from interlock connector pin 1 to pin 8 is required for normal operation. Opening the Inhibit Interlock connection will inhibit the amplifier and display **Fault:Interlock** on the front panel Touch Display.

When the Inhibit Interlock circuit is restored to a closed condition, the Inhibit Interlock fault can be cleared by pressing the **RESET** button on the front panel LCD or by using the remote reset command (when the Toggle Switch is set to **REMOTE**).

2.4 LOCAL USER INTERFACE

This section describes the user interface used during local operation of the amplifier as it pertains to the control system.

2.4.1 Menu Map

Below is a menu map for the amplifier. The screens depicted are only example screens. The actual values and settings will be different on the actual amplifier depending on user settings and operating conditions.

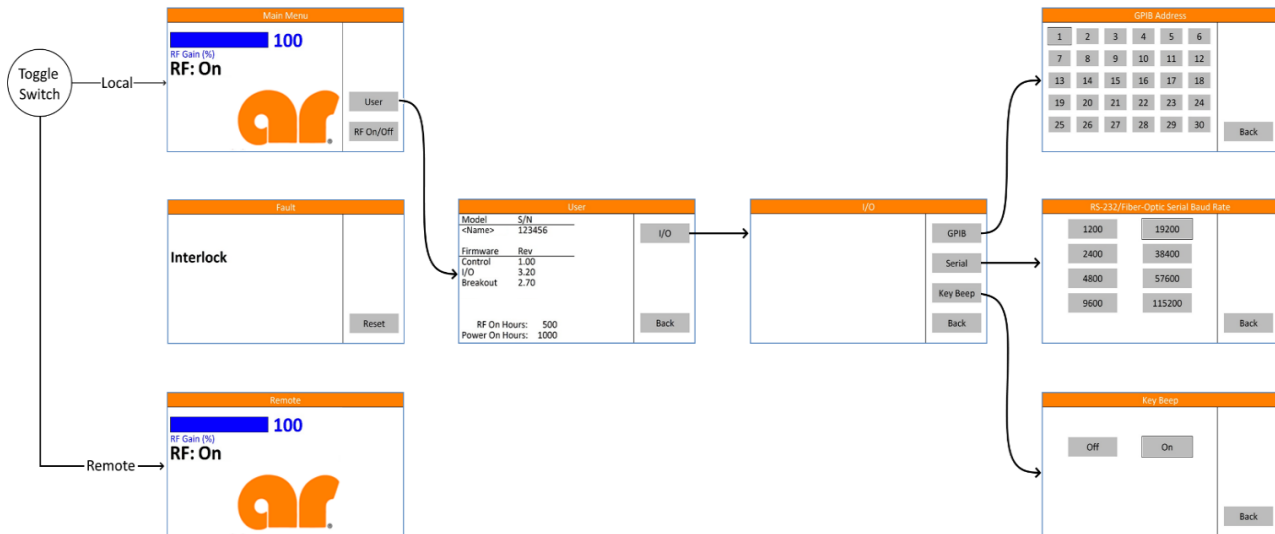

2.4.2 Main Menu Screen

The Main Menu screen is only available when the Local/Remote switch is in the LOCAL position. At the top of the screen is the RF Gain value in the form of a blue bar graph and associated blue numeric value.

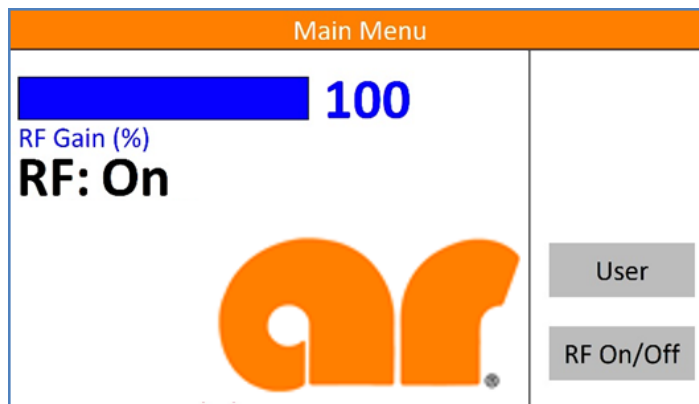

The RF state is shown in bold lettering which can be either Off or On.

The menu options available from the main menu are **User**, and **RF On/Off**. Pressing **User** brings up the User screen and menu. Pressing **RF On/Off** enables or disables the RF path through the amplifier. Pressing **RF On**, causes the amplifier to go to an RF On state.

2.4.3 User Screen

The User screen presents the user with the revision levels of all the firmware that is running on all the main control system components. For the Switch Breakout Board (SBB) assemblies, only the piggy-back assembly firmware is listed. The More button allows the user to see the firmware revisions for all the fiber-optically connected instances of these assemblies. At the bottom of the screen, the RF On and Power On Operating Hours are displayed. A menu option is provided for accessing the settings for the remote I/O ports found on the rear of the unit.

User	
Model	S/N
<Name>	123456
Firmware	Rev
Control	1.00
I/O	3.20
Breakout	2.70
ALC	1.60
RF On Hours:	500
Power On Hours:	1000

2.4.4 I/O Screen

The I/O screen is used to present the user with menu options pertaining to the remote I/O ports found on the rear of the unit and the interaction with the touch screen. These options include the GPIB address, RS-232/Fiber-Optic Serial Baud Rate, and key beep.

I/O	
	GPIB
	Serial
	Key Beep
	Back

2.4.5 GPIB Address Screen

The GPIB address screen is used to select the GPIB address. To get here from the Main Menu, touch the **User** menu button followed by the **I/O** menu button and finally the **GPIB** menu button.

Touching any of the buttons labeled 1 to 30 immediately sets the GPIB address to the corresponding value.

A thin black outline indicates the present GPIB address selection. When the back button is pushed, the address selection is stored to non-volatile memory. Therefore, if power is lost prior to hitting the back button any address selection changes will be lost.

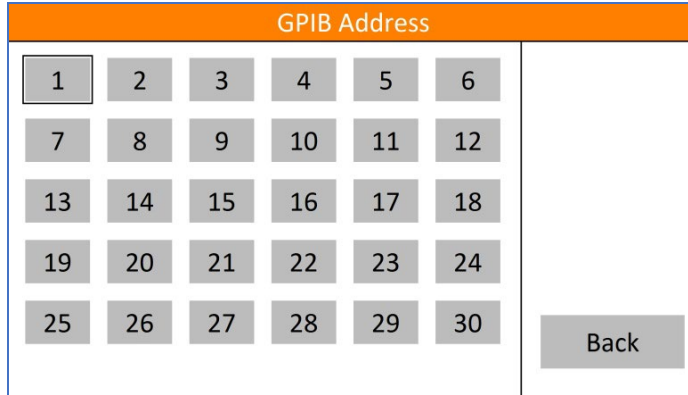

2.4.6 RS-232/Fiber-Optic Serial Baud Rate Screen

The RS-232/Fiber-Optic Serial Baud Rate screen is used to select the baud rate used by both the RS-232 serial port and the Fiber-Optic serial port. To get here from the Main Menu, touch the **User** menu button followed by the **I/O** menu button and finally the **Serial** menu button.

A thin black outline indicates the present baud rate selection. When the back button is pushed the baud rate selection is stored to non-volatile memory. Therefore, if power is lost prior to hitting the back button any baud rate selection changes will be lost. The default baud rate is 19200.

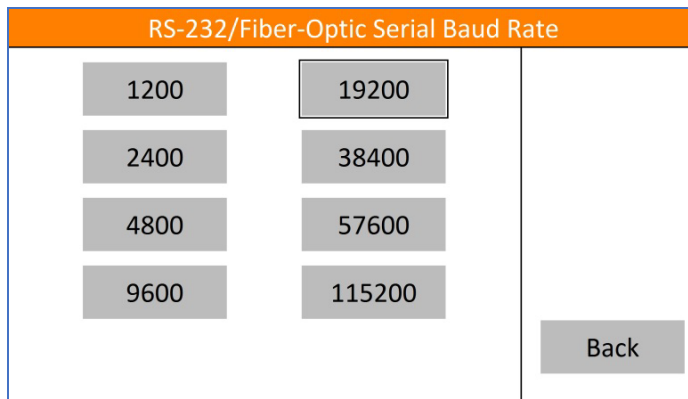

2.4.7 Key Beep Screen

The Key Beep screen allows the user to turn on or off the audible beep that occurs when a valid touch event takes place. This setting is only stored in volatile memory and will be lost when power to the unit is cycled. The default value for this setting is On.

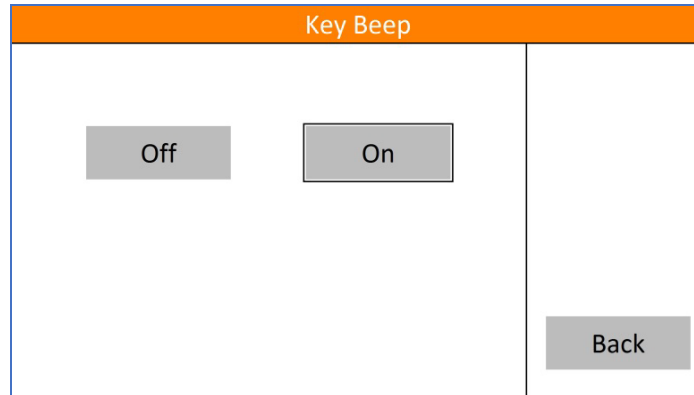

2.4.8 Remote Screen

When the Local/Remote switch is set to the REMOTE position the Remote screen appears. This screen has all the same information as the Main Menu screen except that the **User** and **RF ON/OFF** buttons are not present.

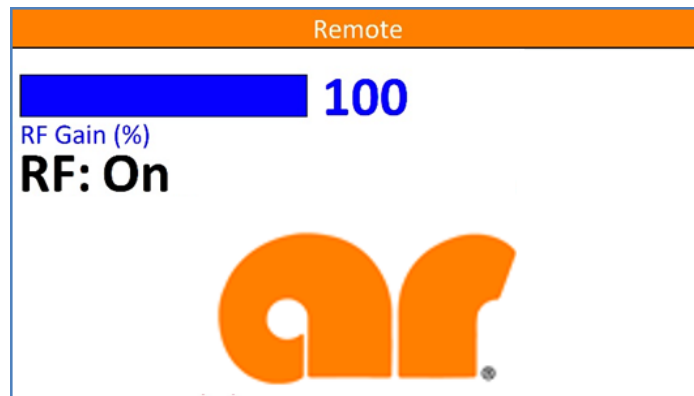

2.4.9 Fault Screen

The Fault screen will appear anytime that a fault condition is met. The name of the fault is shown toward the center of the screen. With the Local/Remote switch set to either LOCAL or REMOTE positions, a Reset button will appear allowing local resetting of the fault condition. Faults can also be reset remotely. If the fault reset is successful, the screen will return to the Main Menu or Remote screen depending on the Keylock switch position.

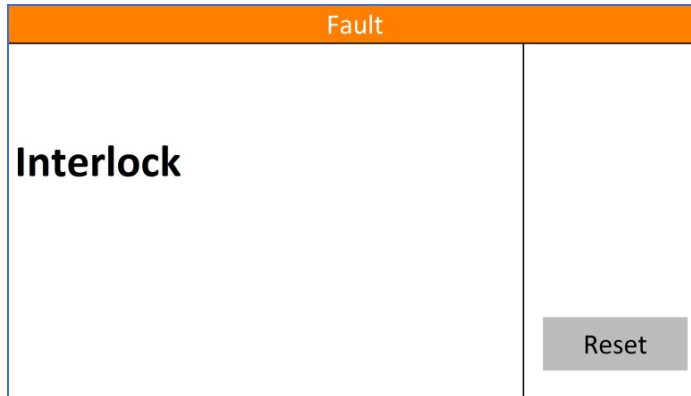

2.5 CONTROL STATES

This section defines the various control software states required for this amplifier. An example of typical control states is shown below. In the subsections below, define any special responsibilities of the control system.

One example would be to state that when transitioning from the RF ON state to the POWER OFF state, care must be taken to remove the bias voltage from the power modules before disabling the main power supplies.

Below is a state diagram for the Power and RF states of the amplifier. This diagram should be used to understand the major states that the amplifier can be in.

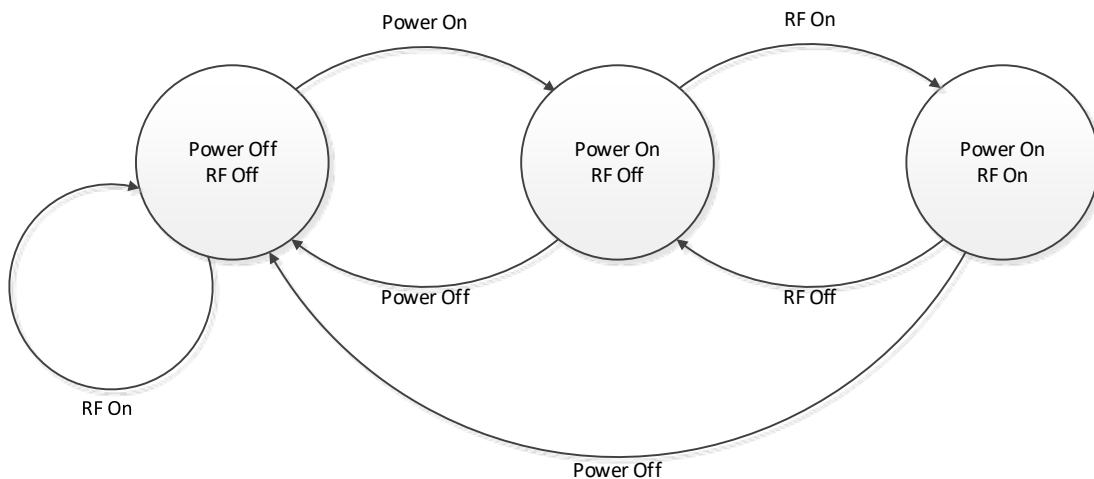

2.5.1 Power Off, RF Off

2.5.1.1 Description

AC power is applied, the Power button has not been pressed (LED status indicator not lit). The control system is waiting for a user action or a remote command.

2.5.1.2 State Change Requirements

No change.

2.5.1.3 System Monitoring Requirements

No faults monitored in the power off state.

2.5.2 Power On, RF Off

2.5.2.1 Description

The Power button has been pressed or the remote command for 'Power On' has been sent.

2.5.2.2 State Change Requirements

Allow 2 seconds of delay before checking sending an FSTA or STATE remote query.

2.5.2.3 System Monitoring Requirements

The controls will actively monitor the thermal faults, Interlocks, and the driver power supply status.

2.5.3 Power On, RF On

2.5.3.1 Description

Amplifier RF output has been enabled.

2.5.3.2 State Change Requirements

Allow 2 seconds of delay before checking sending an FSTA or STATE remote query.

2.5.3.3 System Monitoring Requirements

In addition to the faults monitored in RF:OFF the amp faults and the final power supply status will be monitored.

2.6 CONTROL LINES

This section defines all required control lines to be utilized by the control software and any actions (faults or alerts) that the control software must perform.

In the tables below, indicate the NO ACTION STATES (or the correct operating states) of each line required and any actions that are required if the line is out of bounds.

- If the **Fault?** column is checked, add detailed fault information in section 2.7
- If the **Fault?** column is NOT checked but an action is performed, add detailed action information in section 2.8

2.6.1 Switch Breakout Board (A12A3)

2.6.1.1 Connector J9

Notes	Indicate a range representing a <u>NO ACTION STATE</u> (i.e. +1.2 Vdc << +2.3 Vdc) Once activated, inputs are checked for all following control states Guaranteed operation between 0.0 Vdc and +3.3Vdc (damage occurs outside this range)					
Control Line	Input	Control States Defined in section 4			Fault? ✓ = Yes	General Description Add fault description in section 2.7 Add non-fault description in section 2.8
		<i>Pwr OFF</i> <i>RF OFF</i>	<i>Pwr ON</i> <i>RF OFF</i>	<i>Pwr ON</i> <i>RF ON</i>		
J9 – 1	Analog					
J9 – 2	Analog					
J9 – 3	Analog					
J9 – 4	Analog					

2.6.1.2 Connector J8

Notes	These outputs are not state-driven (always on) and can be set to a fixed value in the range of 0.0 Vdc to 4.8 Vdc	
Line	Output	Value
J8 – 1	Analog	
J8 – 2	Ground	
J8 – 3	Analog	
J8 – 4	Ground	

2.6.1.3 Connector J5

Control Lines	Select Function input or output			Control States Defined in section 4			Fault? ✓ = Yes	General Description Add fault description in Sec 6 Add non-fault description in section 7
	TTL In	TTL Out	OD Out	Pwr OFF RF OFF	Pwr ON RF OFF	Pwr ON RF ON		
	Notes: Lines 3, 4: Supplies +3.3 Vdc via a 10kOhm pull-up resistor Lines 1-4: Guaranteed operation up to +30 Vdc Lines 3, 4: 0 Vdc or +3.3 Vdc TTL Inputs & OD Outputs: Guaranteed operation up to +5 Vdc TTL = Digital OD = Open Drain Indicate <u>NO ACTION STATE</u> for TTL Inputs as HIGH (H) or LOW (L) Indicate required TTL output state as HIGH (H) or LOW (L) Indicate required OD output state as Floating (F) or Grounded (G)							
J5 - 1			✓					
J5 - 2			✓	F	G	G		PS2 On/Off
J5 - 3			✓					
J5 - 4			✓					
J5 - 5		✓		G	G	F		PS1 Enable
J5 - 6		✓						
J5 - 7		✓						
J5 - 8		✓					✓	Flow Rate
J5 - 9	✓							
J5 - 10	✓					H	✓	Amp Fault, A4
J5 - 11	✓							
J5 - 12	✓							
J5 - 13	✓							
J5 - 14	✓							
J5 - 15	✓							
J5 - 16	✓							
J5 - 17	✓							
J5 - 18	✓							
J5 - 19	✓							
J5 - 20	✓				H	H	✓	+5V Fault
J5 - 21	✓							
J5 - 22	✓				H	H	✓	Thermal Fault, PS2
J5 - 23	✓							
J5 - 24	✓							
J5 - 25	✓				L	L	✓	Thermal Fault, Driver
J5 - 26	✓				L	L	✓	Thermal Fault, Final
J5 - 27	✓							
J5 - 28	✓					L	✓	PS2 DC Fault
J5 - 29	✓					H	✓	PS1 DC Fault
J5 - 30	✓				L	L	✓	Interlock
J5 - 31	✓							
J5 - 32	✓							
J5 - 33			✓			+3.3Vdc		
J5 - 34			✓			Ground		

2.7 FAULT DEFINITION

This section is used to define all faults that can occur and their source. Use the Control Line column to define what active control line generates the fault or use the text **Internal** for an internally generated fault from the control system (i.e., *Internal 485 bus error*). See the Control Lines section for details about each control line referenced. See the Control Lines section for details about each control line referenced. If there are more than one Switch Break Out boards, add the interconnect designation to the A# column.

A check mark in the **RF Inhibit** column indicates the RF output of the driver stages will be attenuated. A check mark in the **Drop to RF OFF** column indicates the control state will be changed to *Power ON, RF OFF*.

A#	Control Line	Fault Details				RF Inhibit? ✓ = Yes	Drop to RF OFF? ✓ = Yes
		Hex	Dec	Fault Text (<15 Characters)	Description		
		00	0		No Fault		
A12A3	J5-30	0x0002	2	Interlock	Interlock	✓	✓
A12A3	J5-29	0x0003	3	PS1 DC	Pwr Supply Failure: PS1	✓	✓
A12A3	J5-28	0x0004	4	PS2 DC	Pwr Supply Failure: PS2	✓	✓
A12A3	J5-22	0x000A	10	PS2 Thermal	Pwr Supply Thermal Failure: PS2	✓	✓
A12A3	J5-20	0x000C	12	-5V Fault	-5V Fault	✓	✓
A12A3	J5-10	0x0016	22	Amp A4	Amplifier Fault, A4 Module	✓	
A12A3	J5-26	0x0007	7	Thermal A1	Thermal Fault, Driver	✓	✓
A12A3	J5-25	0x0006	6	Thermal A4	Thermal Fault, Final	✓	✓
A12A3	J5-8	0x0018	24	Flow	Flow Fault	✓	✓
A12A3	J9-1	0x001B	27	Coolant Temp	Coolant temperature too high	✓	✓

2.8 NO-FAULT CONTROL ACTIONS (UTILIZED ON AMPLIFIERS 1000 WATTS AND ABOVE)

This section describes all no-fault actions taken by the controls system and their sources. Use the **Control Line** column to define what active control line generates the fault or use the text *Internal* for an internally generated fault from the control system (i.e., *Internal 485 bus error*). See the Control Lines section for details about each control line referenced.

A check mark in the **RF Inhibit** column indicates the RF output of the driver stages will be attenuated.

A check mark in the **Drop to RF OFF** column indicates the control state will be changed to *Power ON, RF OFF*.

A#	Control Line	Description	RF Inhibit? ✓ = Yes	Drop to RF OFF? ✓ = Yes

2.9 REMOTE CONTROL INTERFACES

This section describes remote operation of the amplifier using the provided General Purpose Interface Bus (GPIB), RS-232 serial port, fiber-optic serial ports, Universal Serial Bus (USB), and Ethernet port. All ports are always active, however only one port may be used at a time.

NOTE: Communicating through two or more ports at one time will cause data collisions and lost commands or queries.

The Local/Remote switch on the control panel of the amplifier enables the remote-control functionality and must be set to the REMOTE position before any commands will be accepted. All remote queries will work with the Local/Remote switch in any position. When the Local/Remote switch is set to REMOTE, all front panel controls are disabled unless otherwise specified.

The status of the amplifier should be checked remotely just prior to issuing a command as well as after a command has been issued to ensure the command has been properly executed. When checking the status after issuing a command, it is good practice to add a delay of 100ms or more to allow the control system time to process the command.

2.9.1 GPIB (IEEE-488) Communications

For GPIB operation, the device address is set using the front panel touch screen. For more information about setting the GPIB address, see the GPIB Address Screen section.

Ensure that each device connected to the GPIB is set to a unique address.

When sending commands via the GPIB interface, terminate commands with an EOI and a Line Feed character.

2.9.2 RS-232 Communications

The RS-232 port is a serial communications bus. When a valid query is received, it is processed, and the result is immediately transmitted back over the RS-232 interface.

Once the first character of a new command or query has been transmitted to the amplifier, any pause between a subsequent character (or the termination character) greater than 5 seconds will result in the internal buffer being cleared and a TIMEOUT_ERROR<LF> message being sent out on this port.

The baud rate for the RS-232 port is user selectable from the RS-232/Fiber-Optic Serial Baud Rate selection screen. For more information, see User Interface section of this document.

NOTE: The baud rate settings are shared by both the RS-232 port and the Fiber-Optic serial port.

General RS-232 settings	
Word Length:	8 bits
Stop Bits:	1
Baud Rate:	User selectable (default is 19200)
Parity:	None
HW Handshake:	None

The RS-232 port is setup as a Data Circuit-terminating Equipment (DCE) port. When connecting to a Personal Computer (PC) a straight one-to-one cable should be used. A null modem is NOT needed. The pinout diagram for this port can be found below.

Pin 1:	DCD
Pin 2:	TD
Pin 3:	RD
Pin 4:	DTR
Pin 5:	GND
Pin 6:	DSR
Pin 7:	CTS
Pin 8:	RTS
Pin 9:	Unused

2.9.3 Fiber-Optic Serial Communications

The Fiber-Optic port is a serial communications bus and is a duplicate of the RS-232 bus. Please refer to the RS-232 Communications section of this manual for general details about port settings.

The Fiber-Optic port provides the user with the ability to optically isolate the controlling PC from the amplifier. This can be useful in an environment where RF/microwave energy could be coupled onto a connection to one of the “wired” communications ports and fed back to the controlling PC.

Both optical connections (TX and RX) are optimized to work with light at a wavelength of 820nm. For more detailed specifications on this port, consult the Avago HFBR series datasheet found at www.avagotech.com.

The recommended specifications for the fiber-optic cable are as follows:

Type:	Glass
Multi-mode:	Yes
Core Size:	50um (minimum) to 200um (recommended)
Connector Type:	ST

This port can be used in conjunction with a serial to fiber-optic or USB to fiber-optic interface, such as an AR IF7001 USB to Fiber-Optic interface.

NOTE: The IF7001 device uses SMA connectors, so a fiber-optic cable is needed with ST connectors on one end and SMA connectors on the other. When the amplifier is connected to an IF7001 device, the baud rate must be set to 19200.

2.9.4 USB Communications

The USB port is a USB 2.0 port. The cable required to make this connection is a USB 2.0 A-B peripheral device cable. The cable should be no longer than 5 meters. If a longer distance is required a USB hub should be used. A cable carrying the official USB logo is recommended.

This port also complies with the USB Test and Measurement Class (USBTMC) Standard. Communications with this port requires the host computer to have a USBTMC driver available. If the amplifier is connected to a PC that has National Instruments LabView installed, the PC will have a USBTMC driver that will work with this port.

The USBTMC driver allows the device to be easily controlled using National Instruments Measurement and Automation Explorer or an application built in the LabVIEW development software.

It should be noted that the USBTMC driver provided by National Instruments is a Virtual Instrument Software Architecture (VISA) driver which can be used with other programming languages besides LabView. For more information on this please consult the National Instruments Website found at www.ni.com.

All commands and queries through this port must be terminated with a Line Feed character.

NOTE: All firmware updates are done through the USB port.

2.9.5 Ethernet Communications

The Ethernet port allows remote control through a Transmission Control Protocol (TCP) data channel. The default the port for the TCP data channel is 10001.

By default, this port is setup to work on a network with a Dynamic Host Configuration Protocol (DHCP) server. Upon connection to the network, an Internet Protocol (IP) address is assigned based on the internal Media Access Control (MAC) address. The MAC address is printed on a label located near the Ethernet port.

NOTE: If connected to a DHCP network, the assigned IP address may be subject to change depending on the network policy. Please contact your network administrator for more information about how IP addresses are assigned and maintained.

If the connected network does not have DHCP enabled, then the device can be assigned an IP address using a utility called DeviceInstaller™, downloaded from www.Lantronix.com. For assistance using this utility please consult the embedded help file installed with the DeviceInstaller utility.

Once installed, the DeviceInstaller™ utility will scan the network and find all connected Lantronix Ethernet devices. This list of found devices will include any connected AR Ethernet devices. By selecting one of the connected devices from the list, its IP address and subnet mask can be changed along, with several other settings. One should use caution when adjusting any unfamiliar settings as doing so may cause the port to become unresponsive.

2.10 REMOTE COMMANDS

A typical command is made up of a key word and a parameter.

A space in a command or response will be indicated as **<space>** in subsequent definitions.

A vertical bar | dictates a choice of one element from a list. For example: **<A|B>** indicates that either A or B can be selected, but not both.

Multiple commands cannot be concatenated within the same character string and any text appearing after a termination character will be ignored by the control software.

Commands are case sensitive and should always be UPPERCASE.

All command and queries must be terminated with a Line Feed Character, indicated as **<LF>** in subsequent definitions.

2.10.1 Power On / Off

This command controls the power state. No other command will be accepted until the **POWER:ON** command has been issued.

It is good practice to wait a minimum of two (2) seconds before polling the status after issuing the **POWER:ON** command.

<i>Syntax:</i>	POWER:<ON OFF>
<i>Query</i>	No (see Amplifier State Query command)
<i>Example</i>	To turn the power on, send the following command: POWER:ON<LF>
<i>Default Value:</i>	OFF

2.10.2 RF On / Off

This command enables the RF output of the amplifier if already powered on and no faults are present.

<i>Syntax:</i>	RF:<ON OFF>
<i>Query:</i>	No (see the Amplifier State Query command)
<i>Example</i>	To enable the RF Output, send the following command: RF:ON<LF>
<i>Default Value:</i>	OFF

2.10.3 RF Gain Adjust

This command sets the RF Gain of the amplifier, in percent.

<i>Syntax:</i>	LEVEL:GAIN<gain value>
<i><gain value>:</i>	Specifies the RF gain in % from 0 (minimum) to 100 (maximum)
<i>Query:</i>	No (see the Machine State query command)
<i>Example</i>	To set the RF Gain to maximum, send the following command: LEVEL:GAIN100<LF>
<i>Default Value:</i>	0%

2.10.4 RF Gain Query

This command queries the RF Gain setting.

Query:	RFG?
Response Format:	RFG=<space><rf gain><LF>
<rf gain>:	The current RF Gain, in percent (0000 to 0100, padded with zeros to always be 4 digits wide).
Example:	To query the RF Gain, send the following command: RFG?<LF>
Response:	RFG=<space>0075<LF> (75% Gain)

2.10.5 Identity Query

This command queries the amplifier for its identity response.

Query:	*IDN?
Response Format:	AR-RF/MICROWAVE-INST,<model>,<firm rev><LF>
<model>:	The model designation of the amplifier.
<firm rev>:	The firmware revision of the control software.
Example:	To query the identity of the amplifier, send the following command: *IDN?<LF>
Response:	AR-RF/MICROWAVE-INST,20SG18A-L,1.0<LF>

2.10.6 IO Board Firmware Revision Query

This command queries the firmware revision of the internal I/O Board.

Query:	*IOB?
Response Format:	INTERFACE_BOARD_SW_REV<firm rev><LF>
<firm rev>:	The firmware revision of the control software.
Example:	To query the firmware of the I/O board, send the following command: *IOB?<LF>
Response:	INTERFACE_BOARD_SW_REV3.20<LF>

2.10.7 Amplifier State Query

This command queries the state of the amplifier.

Query:	STATE?
Response Format:	STATE=<space><char1><char2><char3><char4><LF>
<char1> - <char4>:	ASCII character (0 to 9 or A to F) representing a hexadecimal character
Example:	To query the state of the amplifier, send the following command: STATE?<LF>
Response:	STATE=<space>8301<LF> (Remote Mode, Power On, RF OFF, and Manual Mode)
Each hexadecimal character represents a 4-bit binary number, allowing for a total of 16 binary flags that can be used to indicate various states of the amplifier. The definition of what each bit of information represents can be found in the Amplifier State Response Table below. For help converting the ASCII characters into binary bits, see the Hex character to Binary Bits table.	

Amplifier State Response Table				
	Bit Position	Description	State	Notes
<char 1>	0		-- Not Used --	
	1		-- Not Used --	
	2		-- Not Used --	
	3	Remote Control	0 = Disabled, 1 = Enabled	Response to Local/Remote position REMOTE
<char 2>	0	Power Status	0 = OFF, 1 = ON	
	1	Standby Status	0 = OFF, 1 = ON	Deprecated (use RF Status instead): This line is maintained for backwards compatibility.
	2	RF Status	0 = OFF, 1 = ON	Formerly Operate Status
	3	Fault Status	0 = Okay, 1 = Fault	
<char 3>	0		-- Not Used --	
	1		-- Not Used --	
	2		-- Not Used --	
	3		-- Not Used --	
<char 4>	0		-- Not Used --	This bit will always be ON
	1		-- Not Used --	
	2		-- Not Used --	
	3		-- Not Used --	

2.10.7.1 Hex Character to Binary Bits conversion table

Below is a table that can be used as a reference when deciphering the response from the STATE query. The binary bits of each of the four ASCII characters from the response can be located here.

ASCII Char	Hex character to Binary Bits Equivalent Binary Bits			
	Position 3	Position 2	Position 1	Position 0
1	0	0	0	1
2	0	0	1	0
3	0	0	1	1
4	0	1	0	0
5	0	1	0	1
6	0	1	1	0
7	0	1	1	1
8	1	0	0	0
9	1	0	0	1
A	1	0	1	0
B	1	0	1	1
C	1	1	0	0
D	1	1	0	1
E	1	1	1	0
F	1	1	1	1

2.10.8 Operating Hours (RF ON) Query

This command queries the total hours spent with the RF enabled.

Query:	OH?
Response Format:	OH=<hours><LF>
<hours>:	The total hours with RF Enabled (0 to 100000), padded with spaces to always be 6 digits wide.
Example:	To query the RF On operating hours, send the following command: OH?<LF>
Response:	OH=<space><space><space><space>37<LF> (The system has spent 37 Hours in an RF On state)

2.10.9 Operating Hours (Power ON) Query

This command queries hours spent in Power ON.

Query:	OHP?
Response Format:	OHP=x<LF>
<hours>:	The total hours with Power On (0 to 100000), padded with spaces to always be 6 digits wide.
Example:	To query the Power On operating hours, send the following command: OHP?<LF>
Response:	OHP=<space><space><space>428<LF> (The system has spent 428 Hours in a Power On state)

2.10.10 Faults Query

This command queries information about a currently active fault.

Query:	FSTA?
Response Format:	FSTA=<space><status><LF>
<status>:	A hexadecimal number (0000 to FFFF), padded with zeros to always be 4 characters wide.
Example:	To query the fault status, send the following command: FSTA?<LF>
Response:	FSTA=<space>0003<LF> (Interlock Fault)
Note:	See the Fault Definition section for a detailed description of all faults.

2.10.11 Reset Faults

This command clears a resettable fault. A fault can only be cleared if the underlying issue that created the fault has been resolved.

Syntax:	RESET
Parameters:	None
Example	To clear a reported fault, send the following command: RESET<LF>
Note:	None

2.10.12 SBB (Piggyback) Firmware Query

This command queries the firmware of the piggyback SBB assembly.

Query:	*SBB?
Response Format:	SBB_SW_REV<revision><LF> Where: x is the firmware revision.
<revision>:	The revision of the SBB assembly.
Example:	To query the piggyback SBB firmware revision, send the following command: *SBB?<LF>
Response:	SBB_SW_REV2.70<LF> (Firmware is v2.70)

2.10.13 System Serial Number Query

This command queries the serial number of the system.

<i>Query:</i>	SN?
<i>Response Format:</i>	<number><LF>
<i><number>:</i>	The serial number of the amplifier (6 to 8 characters).
<i>Example:</i>	To query the serial number, send the following command: SN?<LF>
<i>Response:</i>	1234567<LF> (Serial number is 1234567)

3. THEORY OF OPERATION

3.1 INTRODUCTION

The Model 20S6G18A-L RF amplifier consists of a 6.0–18 GHz RF amplifier assembly. The RF amplifier assembly consists of a Pre-Amplifier (Pre-Amp), and a 20-watt module.

The power supply section consists of an AC input filter with a circuit breaker switch, a switching power supply, and a regulator circuit.

The control system consists of a Control/Fault Board, an Interface Board and remote interfaces for IEEE-488, RS-232, USB, and Ethernet.

Reference interconnect diagram 10050716.

3.2 RF AMPLIFIER OPERATION

3.2.1 A1A1 Pre-Amp

The RF input signal is fed to the A1A1 Pre-Amp, RF attenuator U1. U1 is a Gallium Arsenide (GaAs) Field-Effect Transistor (FET) Attenuator. DC signals between approximately -0.5 V to -2.5 V are used to control the shunt and series legs of the RF Attenuator. This Attenuator is used for manual gain control using the front panel gain control and to attenuate RF input signals above 0 dBm by utilizing internal voltages.

U2 is a broadband GaAs Monolithic Microwave Integrated Circuit (MMIC) and is the first stage of gain in the amplifier. The output of U2 is fed to the input of the Wilkinson Two-Way Splitter.

The Wilkinson Two-Way Splitter splits the signal into two paths. One output is fed to the input of the A1A2 Driver Amp and the other output is fed to a detector. The detector output is used to protect the unit in the event of input overdrive.

The output of the pre-amp is fed to the input of a shaper circuit, which flattens the gain.

3.2.2 A4 20-Watt Module

IC U1-U4 are MMIC amplifiers with a current limit of approximately 4 amps for each IC. Each IC monitors the current of 4 FET's. If overall current for each IC falls below or exceeds certain current limit, a fault is displayed on front panel and inhibit +10V to preamp.

A 4-way splitter at the input of the 20-watt module feeds 4 RF channels. All RF circuits are assembled on thin film substrates. The output of the RF channels are then tied to a 4-way combiner. The module has a gain of approximately 20 dB or greater and delivers approximately 20 watts of RF power.

3.3 POWER SUPPLY

There are two power supplies in the 20S6G18A-L amplifier.

Power supply PS1 is a switching supply that automatically sets the AC input circuits to the correct connections for the line voltage 90-132 and 180-250 VAC input ranges 50/60 Hz. The outputs of +24, +12 and -12 volts are used primarily in the A1A1 preamp module, control panel A12A1 and interface board A14.

Power supply PS2 is also a switching supply that automatically sets the AC input circuits to the correct connections for the line voltage 90-132 and 180-250 VAC input ranges 50/60 Hz. This power supply is responsible for the +26.3 V drain bias to the 20 watt amplifier A4.

3.3.1 A7 Regulator Fault Board (Schematic 10044490)

The A7 regulator fault board uses one regulator to convert +24V to +15V to the A1A1 preamp.

The A7 regulator fault board also has two regulators to convert the -12V to -5V for the A1A1 preamp, and A4 20 watt module.

3.4 CONTROL SYSTEM

3.4.1 A12A1 Control/Fault Board (Schematic 10029678)

The A1A1 Control/Fault board consists of two 16-bit microcontrollers and about nine other ICs that monitor and indicate the status of the amplifier. Power is supplied using only a single 5-volt power supply. The board offers the following:

Feature	Quantity
Open drain outputs	2
Digital outputs	12
Digital inputs (5-volt tolerant)	24
Analog outputs	2
Mixed signal inputs	4
2-channel encoder input	1
Inputs for a keypad	8
Display connectors	2
Serial communication jacks	2

4. MAINTENANCE

4.1 GENERAL MAINTENANCE INFORMATION

The Model 20S6G18A-L requires very little maintenance since it is a relatively simple instrument. It is built with thin film substrate etched circuit wiring and solid state devices that will ensure long, trouble free life. However, should trouble occur special care must be taken in servicing to avoid damage to the devices or the thin film circuitry.

Since the components are soldered or epoxied in place, substitution of components should not be resorted to unless there is some indication that they are faulty. All GaAs and GaN FETs are eutectic-attached to a carrier and should only be replaced at the factory. In addition, take care when troubleshooting, not to short voltages across the amplifier. Small bias changes may ruin the amplifier due to excessive dissipation or transients.

Components in AR instruments are conservatively operated to provide maximum instrument reliability. In spite of this, parts within an instrument may fail. Usually, the instrument must be immediately repaired with a minimum of down time. A systematic approach can greatly simplify and, thereby, speed up the repair.

However, due to the importance of the amplifier's alignment, it is recommended that when failure is caused by breakdown of any of the components in the signal circuits, the amplifier be returned to the factory for part replacement and amplifier realignment. Shipping instructions are as follows.

To return an item, contact AR Customer Service for an RMA number and shipping instructions. Returns from outside the United States are not permitted without prior authorization. If shipping from outside of the United States, closely follow all directions on the RMA form for return shipping and marking. See warranty statement at rear of manual.

4.2 DISASSEMBLY PROCEDURE



CAUTION:

Extreme caution should be exercised when troubleshooting this unit, particularly when measuring voltages in the power supply section of the unit. Hazardous voltages do exist in the unit that could cause serious injury to any personnel performing the measurements.

The amplifier can be removed from the housing by removing four screws from the front panel and four screws from the rear securing brackets. The amplifier can then be slid from the housing. The side panel may be removed to access the liquid cooling pump and reservoir. Then the top and bottom covers may be removed to gain access to the RF assemblies. The two power supplies are located near the front panel. The remote interfaces are accessible by removing the rear panel.

4.3 TROUBLESHOOTING



CAUTION:

The microwave devices used in the Model 20S6G18A-L amplifier are GaN MMIC's. These devices are very reliable when installed in a suitable circuit, but they can be easily damaged by improper troubleshooting or handling techniques.

The gate junctions of the GaN and MMIC's have a high input impedance and are susceptible to static damage. Do not try to check them with an ohmmeter.

Use caution when troubleshooting the GaN and MMIC's; do not short the gate to the ground or to the drain.



CAUTION:

Use care when unpacking new GaN and MMIC's. The packaging should only be opened at Electrostatic Discharge (ESD)-approved workstations, by individuals who are familiar with the handling of microwave GaN and MMIC's and other ESD-sensitive devices.

Troubleshooting the Model 20S6G18A-L in a logical manner can speed the solution to a problem. The settings of potentiometers (pots), capacitors (caps), or other variables should not be disturbed until other problems have been eliminated. Comparing the measured DC voltages to those shown on the schematics can solve many problems. Before measuring circuit voltages, first verify that the voltages to the circuits are correct.

Model 20S6G18A-L troubleshooting symptoms and remedies are described in the sections that follow

- 4.3.1— Power On Indication Doesn't Display on Front Panel Liquid Crystal Display (LCD) when POWER Switch is Depressed
- 4.3.2—The Unit Cannot be Operated Remotely
- 4.3.3—Thermal Fault
- 4.3.4—Interlock Fault
- 4.3.5—PS2 Fault
- 4.3.6—Amplifier Faults
- 4.3.7—Low or No Power Output (DC Tests)

4.3.1 Power On Indication Doesn't Display on Front Panel Liquid Crystal Display (LCD) when POWER Switch is Depressed (Schematic Diagram 10050716)

1. If the Model 20S6G18A-L is operating in an otherwise normal fashion, the front panel LCD or the wiring to it could be defective.
2. Check the LOCAL/REMOTE switch on the unit's front panel; it must be set to the LOCAL position in order to operate the front panel POWER switch. Check the AC switch on the unit's rear panel; it must be set to the "1" (ON) position.
3. If the POWER ON indication is not displayed and the cooling fan is not running, check to see that the unit is plugged into a live outlet and that the AC line cord is plugged securely into the unit.
4. Check the output voltage from PS1; this voltage should be as follows:
PS1, P13, Pin 12 + $5.0 \pm 0.2\text{VDC}$
5. If output voltage is not present on PS1, check the AC input to PS1.
6. Check the voltage to the A12A3 Control/Fault Board on connector J5; the voltages should be as follows:
P12, Pin 2 + $5.0 \pm 0.2\text{VDC}$
7. Check the voltage on A12A1, J5, Pin 2; it should be $\geq 3.3\text{V}$ when the **POWER** switch (S1) is in the normal position and $< 0.1\text{V}$ when S1 is depressed. S1 is normally open; it is closed only when it is depressed. The amplifier should change state every time the **POWER** switch is depressed.
8. If all voltages are correct and the unit still does not operate, contact AR to arrange for repair or replacement of the A12A1 Control/Fault Board.

4.3.2 The Unit Cannot Be Operated Remotely

1. Verify that the front panel LOCAL/REMOTE switch is set to the REMOTE position.
2. Verify that the unit operates locally by resetting the LOCAL/REMOTE switch to the LOCAL position; if the unit does not operate locally, see 4.3.1 of this manual.

4.3.3 Thermal Fault (Schematic Diagram 10050716)

During a Thermal Fault, the front panel LCD should read THERMAL FAULT.

1. Try to reset the unit; if the unit resets and operates normally, check to see that the cooling fans (B1, B2, B3 & B4) and pump are operating normally and that the air inlet on the rear and side of the unit are not blocked.
2. If the unit does not reset and the cooling fans are operating normally, check the voltage at the A12A3 Control/Fault Board, J5, pins 25, 26 & 27 should be $\leq 0.1\text{V}$.
3. If the voltage on A12A3 J5, pins 25, 26 & 27 is high, check the connection through S1, S2 or S3, respectively, to ground.

4.3.4 Interlock Fault (Schematic Diagram 10050716)

The Model 20S6G18A-L is equipped with an interlock connector, which is located on the rear panel. The interlock circuit can be used to sense the openings of doors to screen rooms, test chambers, and so forth, and to turn off RF energy when these doors are opened.

NOTE: The Model 20S6G18A-L is shipped with a mating connector, which has a jumper between Pins 1 and 8, installed in the rear panel interlock connector. The unit will not operate unless the interlock circuit is closed.

1. In the event of an Interlock Fault, the front panel VFD should read INTERLOCK FAULT.
2. Check to see if it is safe to be power up the unit—are there personnel present in the screen room, or are doors to the screen room open?
3. After checking for safety, try to clear the Interlock Fault from the front panel by using the RESET switch.
4. If the Interlock Fault will not clear, check for continuity in the External Interlock Circuit (Pin 1 to Pin 8 in the connector, which mate with P1 in the rear panel).
5. Check the voltage on A12A3 J5, pin 30; it should be $\leq 0.1V$.
6. If the voltage on A12A3 J5, pin 30 is high, check the interlock line to ground.

4.3.5 PS2 Fault (Schematic Diagram 10050716)

The PS2 power supply has DC OK output which is normally low ($\leq 0.1V$) to the A12A3 J5, pin 28. If any of the PS2 outputs fail, this output will go high ($\geq 4.0V$) and inhibit the A1A2 Driver Amplifier.

4.3.6 Amplifier Faults (Schematic Diagram 10050716)

1. The individual fault output for the A4 20-Watt module is sensed on the A12A3 Control/Fault Board, J5, pin J10.
2. The chassis top and side covers can be removed to allow access to the RF stages A1A1 and A4. The bottom cover can be removed to allow access to the power supplies, PS1 and PS2.
3. Verify the correct voltages to the RF Stages. Troubleshoot any incorrect voltages.

A1A1 Preamplifier		A1A2 Driver Amplifier		A4 20-Watt Module	
P1, pin 2	+12V	P2, pin 1	-5V	P3, pin 1, 2, 3	+26.3V
P1, pin 3	-12V	P2, pin 4	+26.3V	P3, pin 7	-5V
P1, pin 5	-5V				
P1, pin 6	+10V				

4.3.7 Liquid Coolant

1. If there is a coolant temperature fault, check radiator fan or ambient temperature (too high or too low).
2. If flow fault, check the coolant level, then check quick disconnect.
3. If both are fine, check to see if the pump has stopped.

4.3.8 Low or No Power Output (DC Tests) (Schematic Diagram # 10050716)

All indicators on the Model 20S6G18A-L are normal, the front panel vacuum fluorescent display (VFD) reads **Power On**, and the cooling fans (B1) is operating.

1. Check the position of the RF Gain control—is it set to maximum gain?
2. Check the RF input to the unit—is it the correct amplitude and frequency?
3. Check the RF output connection from the unit—is it correctly connected to the load? Is the coaxial cable okay?
4. Check the following voltages on the Power Supply. If any of the voltages are out of tolerance, correct them before further troubleshooting.

PS1	P13-1	+12 V \pm 0.5V
PS1	P13-12	+5V \pm 0.5V
PS1	P13-8, -9, -10	+24V \pm 0.5V
PS1	P13-13	-12V \pm 0.5V
PS2		+26.3V

5. Check the voltage on the feed thru caps of the A1A1 Pre-Amp, with the RF gain control at maximum gain. Troubleshoot any incorrect voltages.

Pin 2	+12V	\pm 0.5V
Pin 3	-12V	\pm 0.5V
Pin 4, 5	-5V	\pm 0.5V
Pin 6	+10V	\pm 0.5V

6. Check the voltage on the feed thru caps of the A4 20-watt modules. Troubleshoot any incorrect voltages.

Pin 1, 2, 3	+26.3V	\pm 0.5V
Pin 6, 7	-5V	\pm 0.5V

- 7. The Model 20S6G18A-L's typical gain response at 0dBm input and -20dBm input is shown in Figures 4-1 and 4-2. The actual gain may vary considerably from that shown in Figure 4-1, but should be ≥ 43.5 dB. Figure 4-2 should be ≥ 44.0 dB.

NOTE: If the overall gain is low, the amplifier chain can be separated at the input to the A4 20-watt module and the gain checked from the input to the A4 20-watt module to the RF output connector on the unit's front panel.

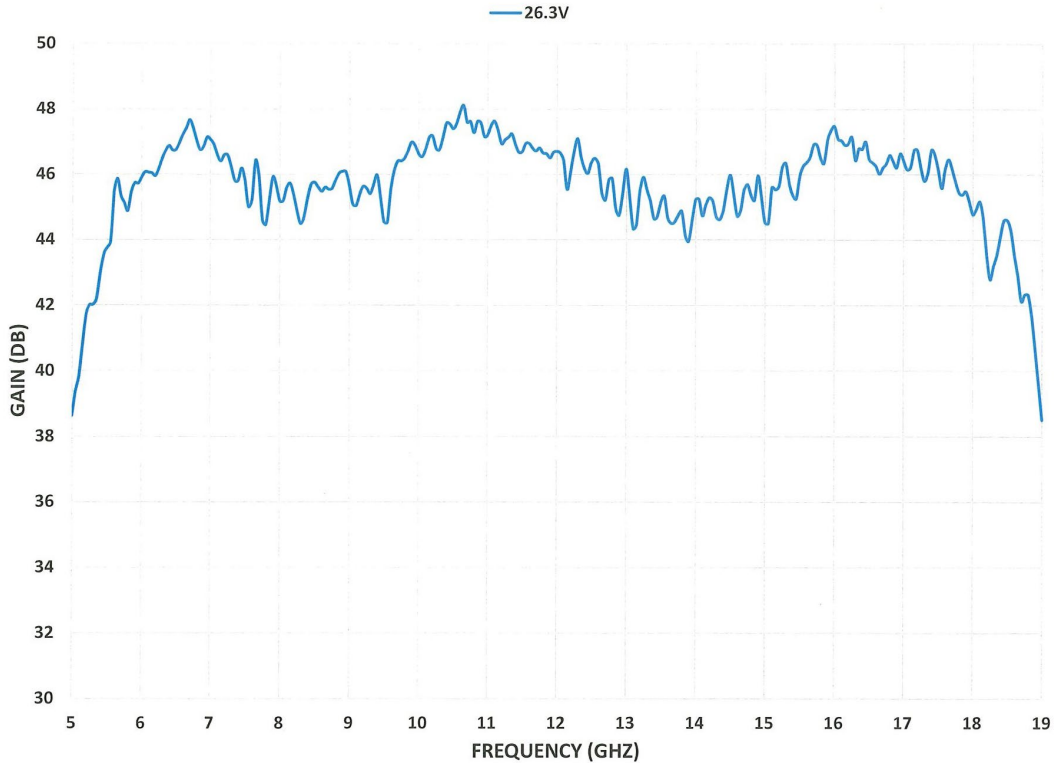

Figure 4-1. Typical Gain Response @ 0dBm input

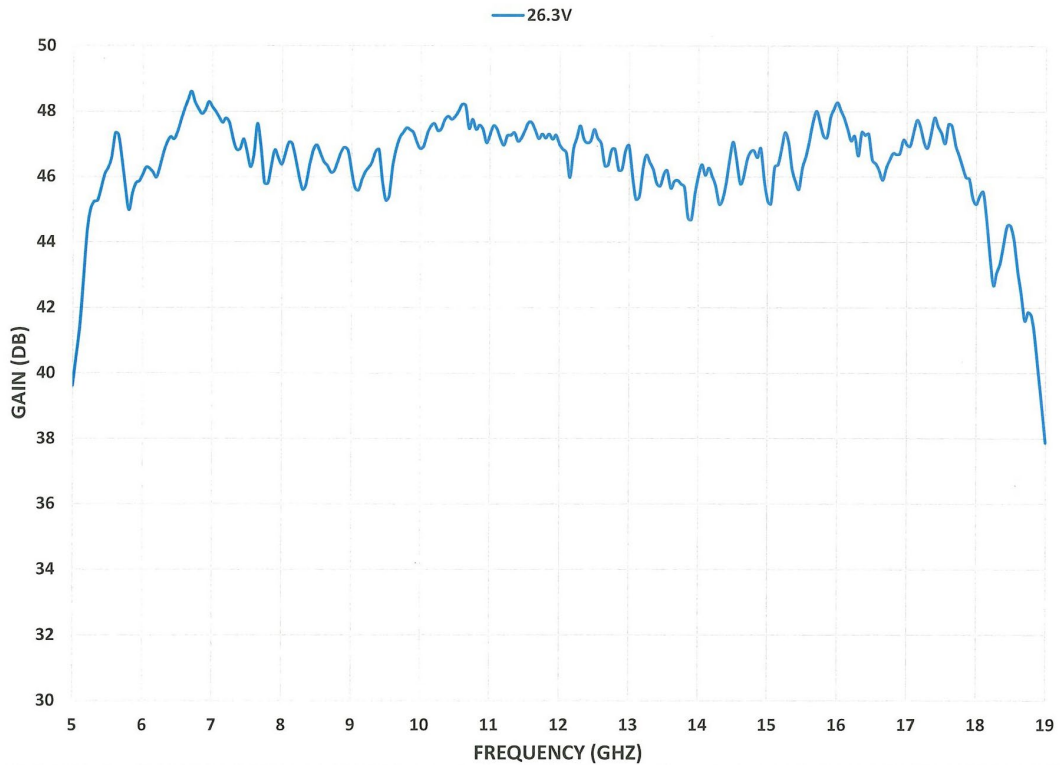

Figure 4-2 Typical Gain Response @ -20 dBm Input

8. Remove the coaxial cable from the output of the A1 Preamplifier to the input of the A4 20-watt module. The typical response from the input of the A4 20-watt module to the RF output connector on the unit’s front panel is shown in Figure 4-3.

If response is normal, see Step 10. If response is abnormal, return amplifier for repair.

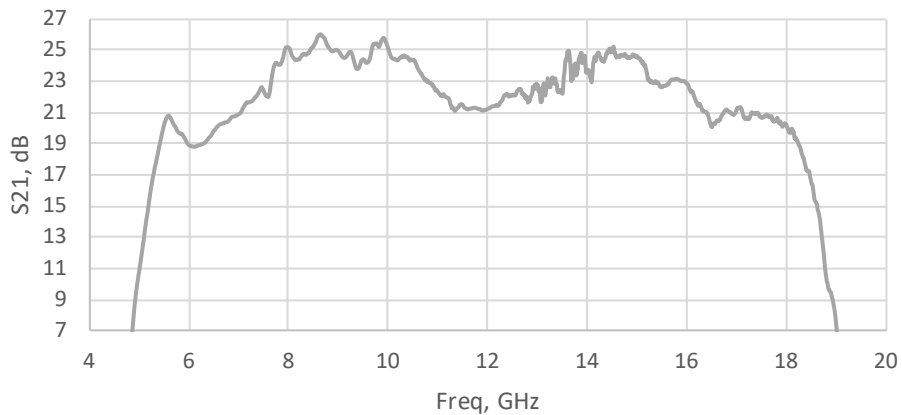

Figure 4-3. Typical Response: Input A4 – Front Panel RF Output

9. If the A4 40-watt Amp is normal, check the A1A1 Pre-Amp. The gain of the A1A1 Pre-Amp should be approximately 1-2 dB with the gain control at maximum. The typical A1A1 Pre-Amp response is shown in Figure 4-4.

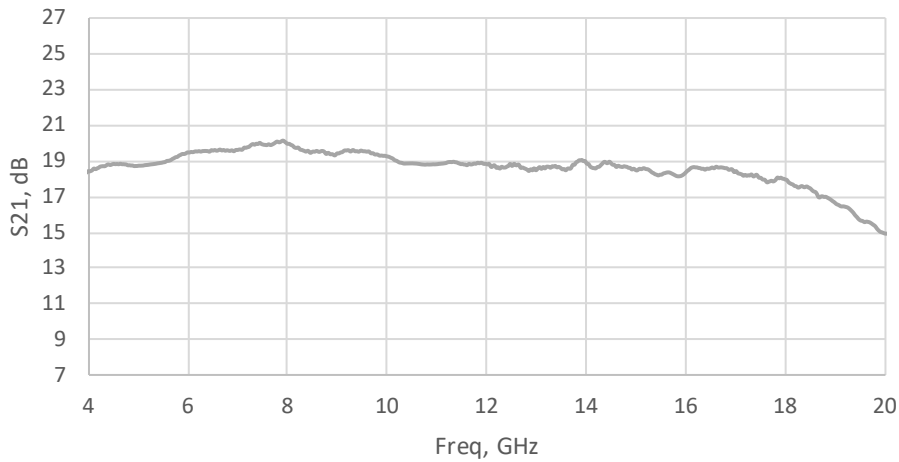

Figure 4-4. Typical A1A1 Pre-Amp Response

4.4 COOLING SYSTEM

The liquid cooling system is a closed system which will operate for years without maintenance. The coolant level should extend into the coolant reservoir, with the heat exchanger full for optimum cooling. The coolant is Koolance LIQ-702 (orange color) 25-30% propylene-glycol with the balance of distilled water. This will provide protection to 5° C (41°F) for operation and -10° C (14°F) for storage. Quick-disconnect leak-proof connectors are incorporated to allow for removal of modules and major system components with no leakage of fluid. If coolant is removed from the system for any reason, the pump should not be activated; damage to the pump can occur if it is run without fluid.

CAUTION:



Contains propylene glycol. Do not swallow. Do not allow eye contact or prolonged skin contact. For additional information, refer to the product's Safety Data Sheet (SDS).

WARRANTIES: LIMITATION OF LIABILITY

Seller warrants (i) that seller has title to the goods sold and (ii) that Amplifiers (all parts excluding traveling wave and vacuum tubes), Antennas, field monitors, field probes, field analyzers, field analyzer processor units, system controllers, system interlock, power meters, leak detectors, RF conducted probes, RF conducted clamps, Multi-tone, EMI receiver systems, RF down converters, RF conducted immunity systems, conducted immunity accessories, radiated immunity test systems, safety meters, safety sensor heads, tripods, directional couplers, waveguide adapters, termination loads, load attenuators, impedance stabilization networks, and coaxial cables will be free from defects in material and workmanship for a period of three (3) years from date of shipment shown on AR RF/Microwave Instrumentation invoice.

All modules, used in the amplifiers for the 1-6 GHz, 4-18 GHz, 6-18 GHz, all HPM products, and other applications, are hermetically-sealed. This sealing process protects the internal hybrid circuitry from humidity that could compromise the long term reliability of the product. These modules are not field-repairable and should *never* be opened outside of AR's Microelectronics Lab. The modules in these product lines have a security label on two sides of the modules between the housing and lid/cover. If the security label is removed and or cut, the warranty of the module will be voided.

Vacuum tubes in the 'L' series amplifiers, traveling-wave tubes in TWT amplifiers, and power heads will be free from defects in material and workmanship for a period of one (1) year.

Contact AR RF/Microwave Instrumentation for warranty information regarding items not listed.

Seller's sole responsibility in fulfilling these warranties shall be to repair or replace any goods which do not conform to the foregoing warranties or, at seller's option, to give buyer credit for defective goods. The warranty is valid only when used in the country specified at time of order. Warranty service must be obtained from the repair facility designated at that time. If warranty service is not available in the country where the equipment is to be used, it must be returned to AR RF/Microwave Instrumentation. Warranty service will be provided only for defective goods which are returned within the warranty period, freight costs prepaid to AR RF/Microwave Instrumentation or its designated repair facility.

There are no other warranties, express or implied, including any warranty of merchantability or fitness. Seller shall not be responsible for any incidental or consequential damages arising from any breach of warranty.

No person other than an officer of Amplifier Research Corporation, has any authority to bind seller to any affirmation, representation or warranty except as specifically included in the preceding terms and conditions.

